



Hydrogen Technology Advisory Group Feb 2011 Meeting in Washington DC

DoD R&D Update

Richard Carlin, Ph.D.

Department Head

Sea Warfare and Weapons Department (ONR 33)

Office of Naval Research





DOD Role in Energy Technologies

- Be an **early adopter** and **principal demonstrator**
- Foster competition in the marketplace and provide a market demand
- Support improved Technology and Manufacturing Readiness Levels
 - Exercise the supply chain
 - Test under real world conditions
 - Provide feedback to manufacturers
- Improve fuel cell readiness by funding R&D efforts in areas that are near commercialization
- Support DOD-unique research to leverage other government and commercial R&D investments



FY10 DoD Hydrogen & Fuel Cell RDT&E Investment

- **Data Highly Dependent on Methods, Questions, Categories & FY time**
 - Requires knowledgeable data collectors & careful planning
- **GAO Report: Batteries, Fuel Cells, Capacitors, Multiple Types**

(Opportunities Exist to Improve DOD's Oversight of Power Source Investments," GAO-11-113 30 Dec 2010)

- **Hydrogen: Not Collected Separately**
- **Fuel Cell: \$43.6M**
- **Multiple Types: \$76.7M (includes substantial fuel cell work)**
- **Clean Energy Data Call, OSD/DDR&E to OMB (Jan 2010)**
 - **Hydrogen: \$18.9M**
 - **Fuel Cell: \$56.2M**
 - **TOTAL: \$75.1M**
- **Caveat on Clean Energy Data Call:**
 - **Navy FY10 (Jan 2010) - Hydrogen: \$0; Fuel Cell: \$20.9M**
 - **Navy FY10 (Sep 2010) - Hydrogen: \$2.7M; Fuel Cell: \$32.9M**



Winning & Preventing Wars with an Energy Strategy



- **Win Wars by Increasing Operational Capabilities through Reduced Demand**
 - ✧ Implement the use of non-petroleum alternative fuels
 - ✧ Install secured alternative/renewable energy at CONUS and OCONUS military facilities
 - ✧ Implement alternative/renewable energy for expeditionary and special operations forces
 - ✧ Increase platform and facilities energy efficiencies
- **Soft Power to Prevent Wars with Strategic Partnerships and Humanitarian Actions**
 - ✧ Implement alternative/renewable energy with global partners
 - ✧ Install alternative/renewable energy during humanitarian operations for enduring use
 - ✧ Implement secured energy partnerships with community at OCONUS military installations

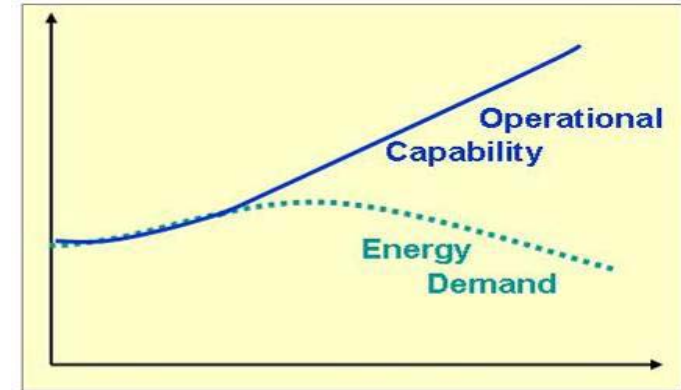

Navy Base Coronado

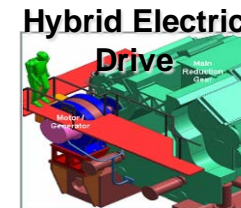



DOD-DOE MOU (July 22, 2010)



Memorandum of Understanding

Between

U. S. Department of Energy

And

U. S. Department of Defense

Concerning Cooperation in a Strategic Partnership to Enhance Energy Security

I. Purpose

The purpose of this Memorandum of Understanding (MOU) is to identify a framework for cooperation and partnership between the Department of Energy (DOE) and the Department of Defense (DOD), hereafter referred to as the Parties, to strengthen coordination of efforts to enhance national energy security, and demonstrate Federal Government leadership in transitioning America to a low carbon economy. This MOU covers, but is not limited to, efforts in the areas of energy efficiency, renewable energy, water efficiency, fossil fuels, alternative fuels, efficient transportation technologies and fueling infrastructure, grid security, smart grid, storage, waste-to-energy, basic science research, mobile/deployable power, small modular reactor nuclear energy, and related areas.

Daniel B. Poneman
Deputy Secretary of Energy

William J. Lynn III
Deputy Secretary of Defense

Enhance Energy Security MOU

The purpose of this MOU is to identify a framework for cooperation and partnership between DOE and DOD to strengthen coordination of efforts to enhance national energy security, and demonstrate Government leadership in transitioning America to a low carbon economy.



Aviation APUs Workshop: 9/30/2010

Purpose:

- To begin discussing collaboration across DOD and DOE in keeping with the MOU
- To motivate RD&D for APU applications

Next Steps

- Identify specific POCs for DOD activities (RED DOTS)
- Develop GSE Strategic Demo Plan

Waste-to-Energy Workshop: 1/13/2011

Purpose:

- To identify DOD-DOE waste-to-energy and fuel cells opportunities
- To identify challenge and determine actions to address them

Next Steps

- Set up an on-going WG to begin coordination, collaboration, assistance
- Develop a guidance document for Feds using third party financing

Shipboard APUs Workshop: 3/29/2011

- March 2011
- Organized by ONR



Fuel-Efficient Shipboard Fuel Cells

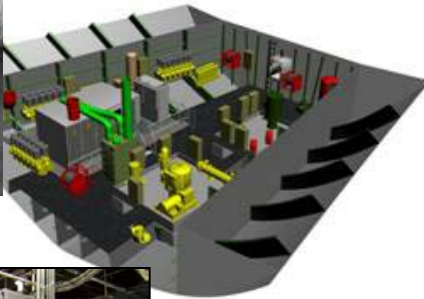

S&T Products:

- Improved fuel cell system efficiency to > 40%
- 3x improvement in reformer power density
- 65% fuel cell stack efficiency at 25% power & 55% at rated power

Objective:

- **Improve:**
 - ❖ Liquid-Phase De-sulfurization
 - ❖ High power density reforming
 - ❖ Fuel cell stacks
 - ❖ Energy recovery & oxidation
- **Conduct shipboard demonstration**

Technical Challenges:

- High capacity liquid-phase de-sulfurization
- Effect of dense hydrogen separation membranes
- Improving reformer efficiencies
- Fundamental knowledge of fuel cell materials
- Fundamental knowledge of liquid fuel vortex combustor operation

Technical Approach:

- Enhance sulfur adsorption bed capacities
- Develop and validate process models
- Demonstrate and validate fuel cell stack characteristics in the Navy environment



Department of the Navy Energy Goals



- **Energy Efficient Acquisition: Evaluation of energy factors will be mandatory when awarding contracts for systems and buildings.**
- **Sail the "Great Green Fleet": DON will demonstrate a Green Strike Group in local operations by 2012 and sail it by 2016.**
- **Reduce Non-Tactical Petroleum Use: By 2015, DON will reduce petroleum use in the commercial fleet by 50%.**
- **Increase Alternative Energy Ashore: By 2020, DON will produce at least 50% of shore-based energy requirements from alternative sources; 50% of DON installations will be net-zero**
- **Increase Alternative Energy Use DON-Wide: By 2020, 50% of total DON energy consumption will come from alternative sources**



Department of Agriculture – DON

21 January 2010



MEMORANDUM OF UNDERSTANDING
between the
DEPARTMENT OF AGRICULTURE
and the
DEPARTMENT OF THE NAVY

I. Purpose and Basis for this Memorandum of Understanding

This Memorandum of Understanding (Agreement) formalizes a relationship between the United States Department of the Navy (DON) and the United States Department of Agriculture (USDA) (hereinafter collectively referred to as “the Parties”).

This Agreement establishes that the Parties agree to encourage maximum use of renewable energy, including outreach to other Federal, State, Local, and Tribal entities, as well as private entities, with the goal of providing technical assistance and financial products to these entities for the development of advanced biofuels and other renewable energy systems. The Federal Government, States, local governments, counties, utilities, private sector, non-governmental organizations, and other entities must all take steps to decrease nationwide energy use through the investment in and effective utilization of new, more efficient technologies, while also emphasizing the development of renewable energy projects.

Through this Agreement, the Parties will work together to support President Obama’s initiative to reduce energy consumption derived from fossil fuels, and to increase energy production from renewable energy sources. Today, the United States depends on imported fossil fuels to meet over 60 percent of its energy needs. This dependence leaves the United States vulnerable to supply disruptions and highly volatile energy prices. Fortunately, the United States has abundant natural resources, including wind, solar, hydrokinetic, ocean thermal, and geothermal sources for electricity generation, and land for energy crops that can be refined into biofuels to meet both commercial and military transportation needs. The Parties are in agreement that developing the United States’ renewable energy economy promises to make the United States a global leader in the production of sustainable, clean, and economically beneficial energy.

Thomas J. Vilsack
 Secretary
 Department of Agriculture
 21 January 2010

Ray Mabus
 Secretary of the Navy
 21 January 2010

that support the President’s renewable

of programs focused on developing
 ncy improvements. These programs are
 Rural Development State Offices, and a

ters the Biomass Crop Assistance
 Title IX of the 2008 Farm Bill. BCAP is
 production of crops for conversion to
 th the collection, harvest, storage, and
 in a biomass conversion facility. As a
 pportunity to encourage landowners and
 cial energy production in ways that are
 und. BCAP is administered through
 s, and more than 2,000 county service

mission area has a comprehensive
 omplementary capacity of its four
 ding scientific knowledge, analysis, and
 economically and environmentally
 ltural Research Service laboratories and
 griculture (NIFA) competitive grant
 sed on development of new varieties and
 mal traits, new optimal production
 sustainable yield of high-quality
 lly preferred biorefining technologies.

ice to respond directly to
 ce will develop and employ proven
 everage public and private investment
 / goals. DON is focusing on adapting
 chitectures for naval installations, while
 energy, advanced biofuels, and
 lations and regions.

and financial expertise in actions
 renewable energy projects, pilots, and
 nforcing strategy and plans to implement
 d initiatives.
 of applicable elements to projects, to the
 s and authorities.
 d implementation venues which develop
 gy processes that are sustainable from an
 ntal perspective.
 formation obtained during the planning and
 es. Confidential data or information shall
 , except as authorized or required by USDA
 tion Act and the Privacy Act.
 y time by mutual agreement of the parties
 y upon 30 days notice in writing to the other

for planning and conduct of specific
 ices of this Agreement shall be designated
 oranda of Understanding developed for
 et for this Agreement are:

nergy Policy
 Deputy Assistant Secretary of the Navy

ent shall become effective upon execution

nding only. It is entered into only as a
 shall be construed as a legally binding
 er individually or collectively. This
 on the part of any party hereto or any third
 conflicts with federal law will be null and



Naval Alternative Fuels



Objectives: Accelerate the adoption of biofuels and blended logistic fuels by supporting Navy certification process, and understand and mitigate the impact of emerging fuels on naval power systems and operations

Key Issues

- Engine (fuel cell?) performance ✓
- Materials compatibility ✓
- Fuel stability ✓
- DON-USDA MOU for Biofuels and Renewable Energy ✓
 - ❖ Biomass sustainability studies with Dept of Agriculture & Hawaii Commercial & Sugar (HC&S)

S&T Investments

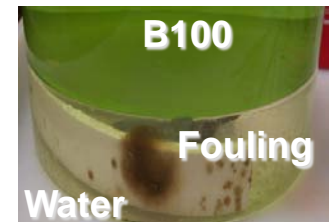
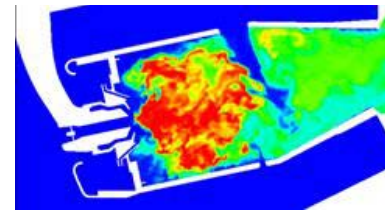
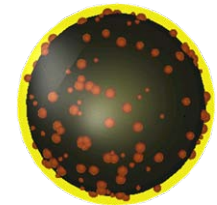
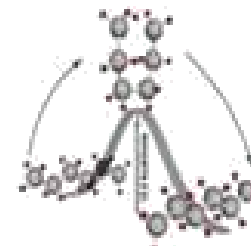



Fundamental Chemistry and Physics of Direct-Electrochemical Oxidation (DECO) in Solid Oxide Fuel Cells

R. J. Kee, Colorado School of Mines (FY03 – FY07)



S&T Objective

Elucidate chemical and electrochemical oxidation of hydrocarbon molecules in solid oxide fuel cells to facilitate optimization of fuel/fuel cell electrochemical power source systems.

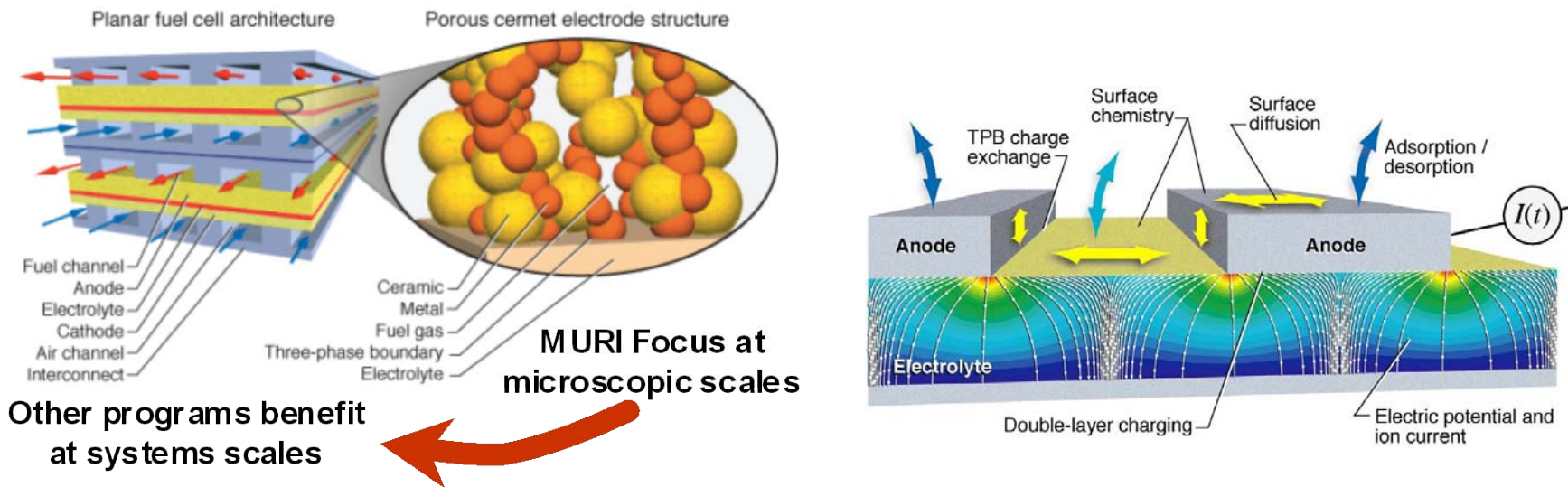

Warfighter & Payoffs

- Compact, high-power-density fuel cell power sources operating on diesel-like hydrocarbon fuels (no reformer required!)
- Insight for development of assured Naval fuels for the future



Hydrogen Energy Systems as a Grid Management Tool

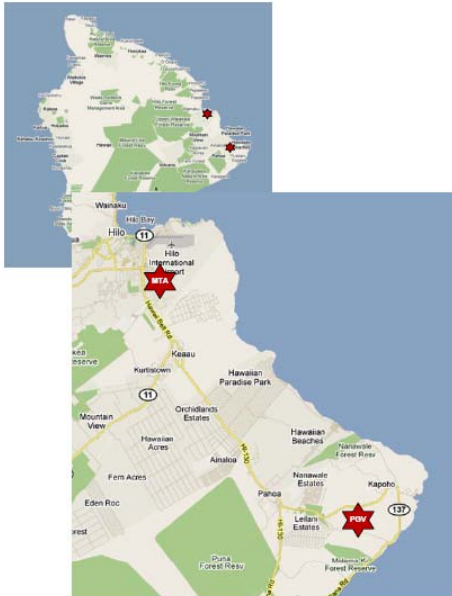

Locations of PGV & MTA

- Demonstrate the use of hydrogen/fuel cells as a grid management tool to mitigate the impacts of renewable energy
 - Develop hydrogen production infrastructure at Puna Geothermal Site
 - Characterize performance and durability of commercially available electrolyzer operated under dynamic load conditions
- Provide hydrogen for transportation and other high value applications
 - Provide hydrogen to fuel two Ford E450 IC shuttle buses for local community bus service operated by County of Hawaii Mass Transit Agency
 - Conduct performance/cost analysis to identify benefits of integrated system including grid services and off-grid revenue streams

-
- US Department of Energy: Project Sponsor & Funding
 - Office of Naval Research: Supplemental Funding
 - State of Hawaii: Cost Share via HI H2 Power Park
 - Naval Research Laboratory: Federal Technical Program Manager
 - Hawaii Natural Energy Institute: Implementing Partner, Technical Lead
 - Puna Geothermal Venture: Host Site, Provide Power and Water (Cost Shared)
 - County of Hawaii Mass Transit Agency: Host Site, Bus Operator (cost shared)
 - HELCO: Interested Observer, Potential Partner for Grid Analysis



Hawaii Hydrogen Power Park

Demonstrate Dynamic Operation of Electrolyzer to Evaluate Potential of Hydrogen Production to Provide Grid Support

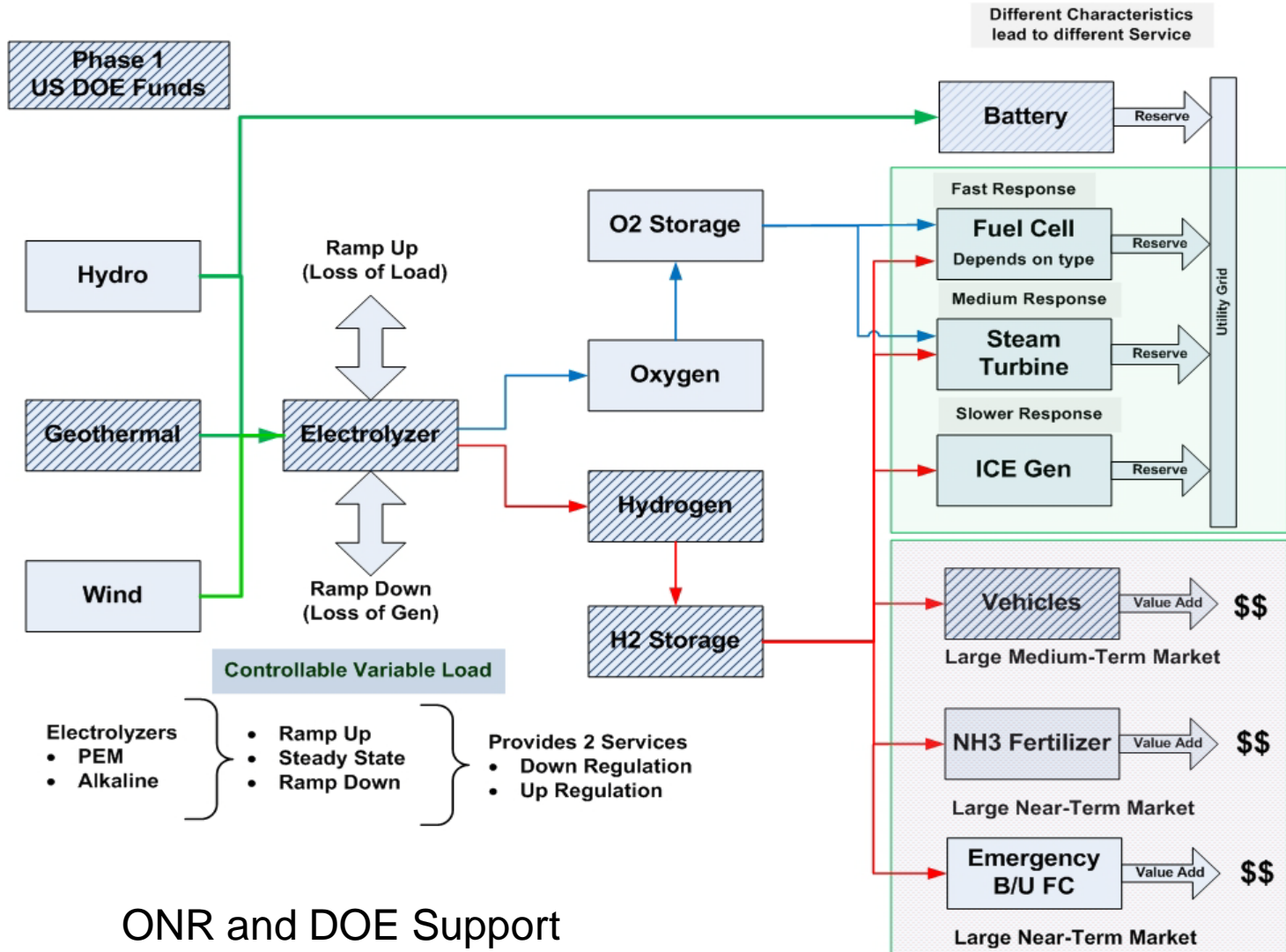

ONR and DOE Support

Manhattan Project in Fuel Cell Manufacturing

This is a collaborative effort sponsored by the ONR through the B2PCOE

- B2PCOE
- Montana Tech
- SME's



Industry
Academia
Government
FC Consortia

Participants

- Dave Carter – Argonne
- Mark Cervi – GDIT / NSWC
- Paul Chalmers – Hydrogenics
- John Christensen – NREL / DOE
- Aaron Crumm – AMI
- Bill Ernst – Consultant
- Matthew Fay – General Motors
- Marc Gietter – CERDEC
- Leo Grassilli – ONR
- Rick Kerr – Delphi Corp
- Dennis Kountz – DuPont
- Randy Petri – Versa
- Raymond Puffer - RPI
- Joylon Rawson – Acumentrics
- Richard Reilly – Stevens Institute
- Steve Rock – RPI
- Kathryn Rutter - Ballard
- Shailesh Shah – CERDEC
- Duarte Sousa – Ballard
- Matt Steinbroner – Protonex
- Scott Swartz – NexTech
- John Trocciola – Consultant
- Mike Ulsh – NREL/DOE
- Doug Wheeler – DJW Tech
- Robert Hyatt – MTT
- Randy Hiebert – MTT
- Jay McCloskey – MTT
- Brian Park – MTT
- Carmine Meola – ACI
- Rebecca Morris – ACI

Objectives Phase 1 – Oct 2010

- ✓ Identify manufacturing barriers to achieving affordability
- ✓ Identify best practices in fuel cell manufacturing technology
- ✓ Identify manufacturing technology gaps

Objectives Phase 2 – Mar 2011

- Produce a Manufacturing Technology Roadmap
- Articulate projects to resolve the gaps
- Prioritize a strategy for effective investment:
- Manhattan fuel Cell publication: Oct. 2011





Soldier Portable and Squad Level Fuel Cells



DESCRIPTION

- Develop Soldier Portable (50 watt) and Squad Level (300 watt) fuel cells
- Leverage existing technologies to mitigate risk
- Conduct field testing of systems to prove designs and gain assure user acceptance
- Implement plans to increase reliability and decrease unit cost
- Initiate LRIP
- Transition products to PM SWAR and DLA.

50 watt



300 watt



BENEFITS/METRICS

- Establish domestic production base
- Reduce unit price on emerging technology
- Economic stimulus to U.S. industry through job creation and retention.

WARFIGHTER IMPACT

- ✓ Decreased dependence on fossil fuel generators
- ✓ Increased ability for use of rechargeable batteries in remote locations
- ✓ Manportable, silent energy source for forward bases
- ✓ Increased user acceptance of this new power source
- ✓ First Fieldings
 - USAF Battlefield Airman Operator Kit Increment II
 - Ground Soldier System (2012)
 - Other uses are as power source for standard Army chargers, remote sensor locations and portable APU applications
- ✓ Usage expected to increase as unit cost goes down and reliability increases



Soldier Portable & Squad Level Fuel Cells



ARRA 300W Fuel Cell Program

Requirement	Proposed Approach	Requirement	Proposed Approach	Requirement	Proposed Approach
Weight	22 lbs	Weight	35 lbs	Weight	36 lbs
Volume	10.34" x 8.6" 16.5", 22L	Volume	11.4"x 8.7" x21.7"	Volume	23" x 10" x 14"
Fuel	Commercial Propane	Fuel	100% Methanol (MeOH)	Fuel	Methanol (MeOH)/H2O mix
MTBF	1080 hrs/3000 hrs	MTBF	1080 hrs/3000 hrs	MTBF	1080 hrs/3000 hrs
Internal Start Up Battery	Li - 145	Internal Start Up Battery	BB-2590	Internal Start Up Battery	BB - 2590
Start Up Time	15 mins.	Start Up Time	Instant w/battery, 5-10 mins. (fuel cell)	Start Up Time	30 mins.

Adaptive Materials Inc

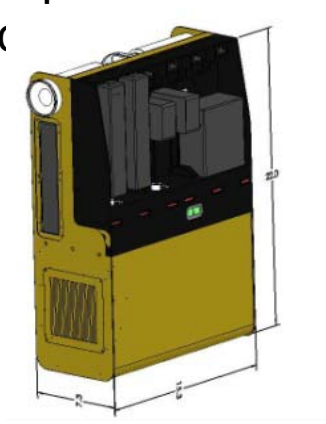

Bren-tronics Inc.



Protonex





Unmanned Systems Fuel Cell Power



Unmanned Air Vehicle Power

- Long endurance fuel cell power
 - 26 hr flight Nov 2009
- 500 W Protonex PEM on H₂
- Low noise & heat signature

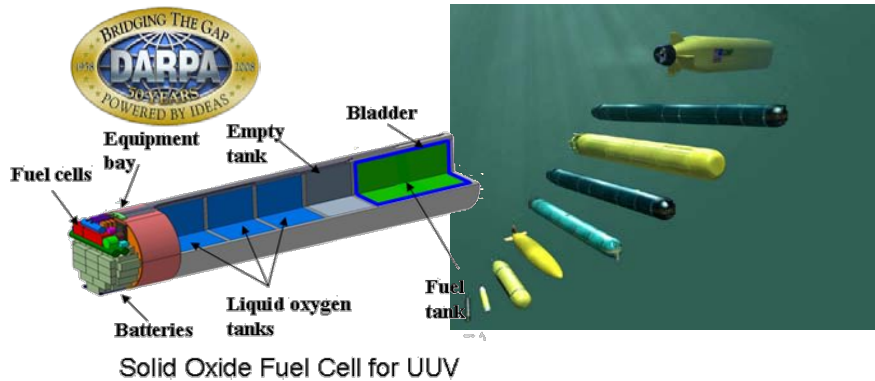

Unmanned Undersea Vehicle Power

- Air independent power systems: fuel cell, hybrid electric, hydro-reactive, etc.
- General Motors automotive 93-kW proton exchange membrane (PEM) fuel cell system with hydrogen as fuel and oxygen as oxidizer

Fuel Cell Testing

- Cell & Stack Testing
- Hardware-in-the-Loop System & Component Evaluation





Low Signature Generators & APUs



US Army Corps of Engineers
Engineer Research and Development Center
Construction Engineering Research Laboratory

BUILDING STRONG®



Regenerative Fuel Cell System for Silent Camp™ Operations

- Fuel cell – electrolyzer – diesel generator hybrid power system using hydrogen for energy storage
- High pressure Proton Energy electrolyzer coupled to 30 kW tactical diesel generator as the primary power source
- High pressure hydrogen stored and used in a 5kW Alteryg PEM fuel cell for Silent Camp™



Solid Oxide Fuel Cell APU



Vehicle Based APU



Towable Power

- SOFC operating on desulfurized JP-8 and synthetic/biofuels fuels
- Provides quiet, low IR signature, low emissions mobile power generation
- Power Output: 10kW (threshold) 15kW (objective)
- Efficiency: >30%
- Total System Volume: 30 watts/liter
- Weight: 35 watts/kilogram



Fuel Cell Pilot Project

Defense Depot Susquehanna, PA



Objectives:

- Explore fuel cell infrastructure and functionality in place of lead acid batteries in forklifts
- Develop a business case for fuel cells
- Collect and analyze operational data

Approach:

- 2-year pilot project
- Retrofit 40 forklifts with fuel cells (20 existing lifts and 20 new leased lifts)
- Compare products from two fuel cell producers
- Set up storage & indoor dispensing systems for delivered liquid H₂

Customers: Defense Depot at New Cumberland, PA (DDSP)

DOD Benefits:

- Develop knowledge of fuel cell powered fork lift capabilities, costs, limitations, and benefits
- Improve Manufacturing Readiness Levels (MRLs) and costs

Performers: Air Products, Plug Power, East Penn/Nuvera

Schedule/Milestones:

- Contract award - Aug 2007
- Operational phase - Feb 2009 to Feb 2011
- Interim business case analysis - Dec 2009
- Transition decision - Summer 2010

Budget: \$6M

Over 50,000 operating hours, 15,000 refuelings, 10,000 kg of H₂ dispensed



Fuel Cell Pilot Project

Defense Depot Warner Robins, GA



Objectives:

- Expand infrastructure exploration to include on-site reformation and mobile refueling
- Continue to develop business case for fuel cells
- Analyze operational data

Approach:

- 2-year pilot project
- Retrofit 20 forklifts with fuel cells
- H₂ reformed on site from natural gas
- Test mobile refueling

Customers: Defense Depot at Warner Robins (DDWG)

DOD Benefits:

- Further knowledge of fuel cells, on-site reformation, and mobile refueling
- Improve Manufacturing Readiness Levels (MRLs) and costs for fuel cells and infrastructure

Performers: Concurrent Technologies Corporation, Air Products, Hydrogenics

Schedule/Milestones:

- Contract award - Jun 2008
- Construction start - Aug 2009
- Operational phase - Nov 2009 to Nov 2011

Budget: \$5.5M



Fuel Cell Pilot Project

Joint Base Lewis-McChord (JBLM), WA



Objectives:

- *Explore H₂ production from wastewater digester gas*
- Expand knowledgebase for fuel cell applications
- Continue to develop business case
- Analyze operational data

Approach:

- 19 new forklifts
- “Green” H₂ production source
- Bus operated with McChord AFB
- Mobile refueler for dispersed activities

Customers: US Army (Depts. of Public Work & Logistics), Joint Base Lewis-McChord (JBLM), WA

DOD Benefits:

- Expanded knowledge of fuel cell costs and benefits for renewable H₂
- Improve Manufacturing Readiness Levels (MRLs) and costs for fuel cells and tri-generation systems
- Explore and support sustainable closed loop operations

Performers: Center for Transportation and the Environment (CTE), Air Products, GTI/Versa, Plug Power, Mobile Energy Solutions

Schedule/Milestones:

- Contract award - May 2009
- Construction start - Summer 2010
- Operational phase - Oct 2010 to Oct 2012

Budget: \$8.6M



Fuel Cell Pilot Project

Defense Depot San Joaquin, CA

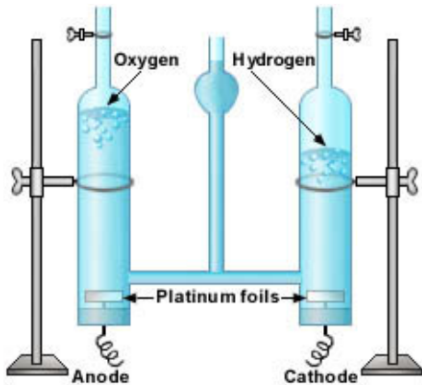

Objectives:

- “Green” H₂ production from photovoltaics
- Replace propane combustion powered forklifts
- Analyze operational data
- Continue to develop business case (compare to propane operations)

Approach:

- Replace 20 propane forklifts
- Generate H₂ on-site using solar energy
- DESC to negotiate a Solar Power Purchase Agreement (PPA)

Customers: Defense Depot at San Joaquin, CA (DDJC)

DOD Benefits:

- Expanded knowledge of fuel cell costs and benefits
- Improve Manufacturing Readiness Levels (MRLs) for fuel cells and electrolyzers
- “Green” hydrogen – reduced CO₂ emissions

Performers: CTE, APCI, Proton Energy, Plug Power

Schedule/Milestones:

- Contract award - Apr 2010
- Construction start - Jun 2010
- Solar PPA - Jun 2010
- Operational phase - Oct 2010 to Oct 2012

Budget: \$6.1M



Passenger Ground Vehicles

Non-tactical Hydrogen Powered General Motors Fuel Cell Vehicles and Hydrogen Infrastructure

- Evaluation ongoing at Camp Pendelton
- Planned evaluation by MARFORPAC in Hawaii
- Coordinating with other Services and DoE



Marine Corps Base
Camp Pendleton



MARFORPAC &
Marine Corps Base Hawaii



Hawaii Advanced Vehicle Working Group (HAVWG)





High Power Mobile Platform Power



Fuel Cell Locomotive



US Army Corps of Engineers
Engineer Research and Development Center
Construction Engineering Research Laboratory

BUILDING STRONG®

- Hybrid power: Two 125 kW Ballard fuel cell stacks with 1 MW lead acid battery bank
- 70 kg of on-board compressed hydrogen
- Partnership: CERL, Vehicle Projects Inc. & Burlington Northern Santa Fe Railway

Ship Service Fuel Cell



600 kW Reformer System
Using High Sulfur Logistics Fuel



500 kW Diesel Fuel Processor
for a PEM Fuel Cell





Joint Base Pearl Harbor-Hickam Renewable H₂ Production & Fueling Station



Deployable Modules

- Hydrogen Fuel Processor (H₂FP) uses two electrolyzers; produces up to 50kg/day.
- Hydrogen Pressure Management (H₂PM) pressurizes H₂ up to 5000psi.
- Hydrogen Pressure Storage (H₂PS) stores H₂ at 5000psi.
- Water filtration
- Power Control
- MEP 9 Generator for deployment
- Operating since Nov 2006

146 kW Photovoltaic Array

- Provides power to base grid when station is not operating.
- Operating since May 2009

Five 10 kW Vertical Axis Wind Turbines

- Additional renewable energy for hydrogen station; power to base grid when station is not operating.





Smart Power Infrastructure Demonstration for Energy Reliability and Security (SPIDERS)



Reduce the “unacceptably high risk” of extended electric grid outages by developing the capability to “island” installations while maintaining operational surety & security

HICKAM AFB CIRCUIT LEVEL DEMO

- Renewables
- Hydrogen Storage
- Hydrogen Fuel Cell
- Energy Management
- VSE SCADA Test at Idaho National Lab

FT CARSON MICRO-GRID

- Large Scale Renewables
- Vehicle-to-Grid
- Smart Micro-Grid
- Critical Assets
- CONUS Homeland Defense Demo
- COOP Exercise

CAMP SMITH ENERGY ISLAND

- Entire Installation Smart Micro-Grid
- Islanded Installation
- High Penetration of Renewables
- Demand-Side Management
- Redundant Backup Power
- Makana Pahili Hurricane Exercise

TRANSITION

- Template for DoD-wide implementation
- CONOPS
- TTPs
- Training Plans
- DoD Adds Specs to GSA Schedule
- Transition to Commercial Sector
- Transition Cyber-Security to Federal Sector and Utilities





Alternative Energy Research



➤ Alternative Fuels

- ❖ Fuel chemistry, combustion process analysis [collaborative with other services]
- ❖ Material compatibility and storage/degradation analysis
- ❖ Methane hydrates characterization and international surveys
- ❖ Biofuel production process analysis & feedstock assessments [Navy and joint with DoAg]



➤ Hydrogen (H2), Fuel Cell Research and Evaluation

- ❖ H2 production and storage for grid stabilization [planning with DoE, Puna Geothermal and Hawaii Electric Light Co]
- ❖ Non-tactical vehicle evaluation and grid interface [joint with other services & DoE]
- ❖ Fuel Cell back-up power systems [Navy and joint with DoE]
- ❖ Unmanned systems evaluation
- ❖ Fuel cell materials research [joint with DoE]

H₂ Powered FC Vehicles



Hawaii Fuel Cell Test Facility

➤ Renewable Power Generation

- ❖ Ocean Thermal Energy Conversion heat exchanger corrosion and biofouling evaluation [joint with NAVFAC and DoE]
- ❖ Solar photovoltaic and small wind systems evaluations

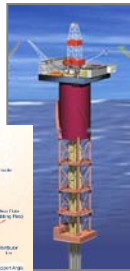

➤ Energy Security and Renewable Penetration Impact Mitigation

- ❖ Megawatt energy storage for grid stabilization [collaborative with DoE and Hawaii Electric Light Co]
- ❖ Grid modeling and analysis [joint with DoE]

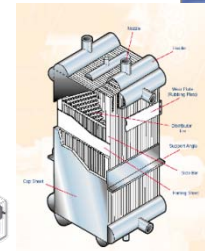

➤ Energy Efficiency

- ❖ Energy neutral-to-energy positive structures
- ❖ Ice production/water purification system evaluation



FROG ZERO Hawaii Project

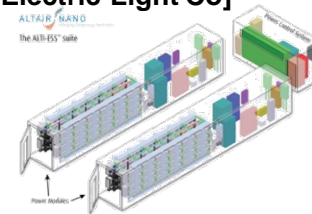

➤ Alternative Energy Analysis and Outreach

- ❖ STEM programs K-12 & Community Colleges (Hawaii CCs), U Hawaii and U Guam [collaborating with SPAWAR]
- ❖ Power Systems workforce development [University of Hawaii, and Florida State University consortium]





H₂-FC Sustainable Infrastructure

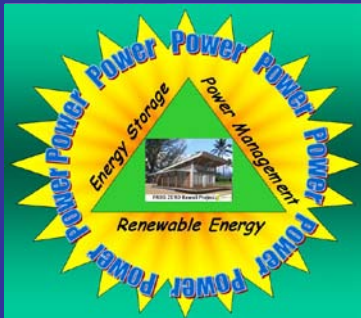

Energy Storage



Optional Grid Connection



Fuel Cell UAV ISR



Solar PV

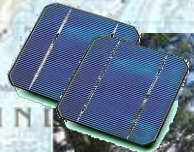

Wind



FROG ZERO Hawaii Project



FROG ZERO Hawaii Project

Smart Grid Interface



Electric or Fuel Cell Vehicles



Fuel Cell / Electrolyzer



Reverse Osmosis Water Unit



Fuel Cell UGV
ISR / Sentry

Scale: 1:36,000,000 at 30°S
Alexander Projector
0 100 200 Miles



Summary



- DoD-DoE MOU offers new opportunities for coordination & collaborations
- DoD promoting early adoption:
 - Forklifts & other Materials Handling/Ground Support Vehicles
 - Fuel Cell Passenger Ground Vehicles
 - Distributed Home & Building Fuel Cell Electricity & CHP
 - Remote & Facility Backup Power (ERDC-CERL: 217kW of fuel cells @ 9 Federal Facilities)
 - Portable Power
- DoD promoting and developing new applications:
 - Unmanned System Power
 - Waste-to-Energy
 - Shipboard Auxiliary Power: Biofuel-Fuel Cell
 - Aircraft APU
 - Grid/Micro-grid Power Management & Energy Security
- DoD Coordination Activities
 - Interagency Working Group led by DoE
 - DoD Fuel Cell Working Group
 - DoD Coordination Website being discussed with ERDC-CERL
 - Planning documents, e.g. Manhattan Project

