

MASS-PRODUCTION COST ESTIMATION OF AUTOMOTIVE FUEL CELL SYSTEMS

HTAC OPEN MEETING

**BRIAN JAMES &
JEFF KALINOSKI**

JULY 15, 2009



3601 WILSON BLVD
SUITE 650
ARLINGTON, VA 22201
703.243.3383

Presentation Outline

- Program Overview
- General Rules
- Methodology
- Markup Basics
- Key System Attributes
- Stack Components
 - Bipolar plates & coatings
 - Membrane
 - Catalyst Ink & Application
 - GDL
 - Hot Pressing
 - MEA Cutting
 - MEA Frame Gasket
 - Coolant & End Gaskets
 - Endplates & Current Collectors
 - Stack Assembly
 - Stack Conditioning
 - **Stack Cost Summary (page 29)**
- Balance of Plant Components
 - H₂ Sensors
 - Belly Pan
 - Wiring
 - Compressor/Motor/Expander Unit (CMEU)
 - System Assembly
 - **BOP Cost Summary (page 36)**
- System Summary & Sensitivities
- Future Work
- Further Details
 - Full-size system schematics
 - Markup details
 - Bill of Materials showing cost details for each system

Overview

Timeline

- Base Period: Feb '06 to Jan '08
 - 100% complete
- Option Year 1: Feb '08 to Jan '09
 - 100% complete
- Option Year 2: Feb '09 to Jan '10
 - 10% complete

Barriers

- Manufacturing costs
- Materials costs (particularly precious metal catalysts)

Collaborations

- Extensive interaction with industry/researchers to solicit design & manufacturing metrics as input to cost analysis.

DOE Cost Targets

Characteristic	Units	2008	2010	2015
Stack Cost	\$/kW _{e (net)}	-	\$25	\$15
System Cost	\$/kW _{e (net)}	-	\$45	\$30

Objectives

1. Identify the lowest cost system design and manufacturing methods for an 80 kW_e direct-H₂ automotive PEMFC system based on 3 technology levels:

- 2008 status technology
- 2010 projected technology
- 2015 projected technology

2. Determine costs for these 3 tech level systems at 5 production rates:

- 1,000 vehicles/year
- 30,000 vehicles/year
- 80,000 vehicles/year
- 130,000 vehicles/year
- 500,000 vehicles/year

3. Analyze, quantify & document impact of system performance on cost

- Use cost results to guide future component development

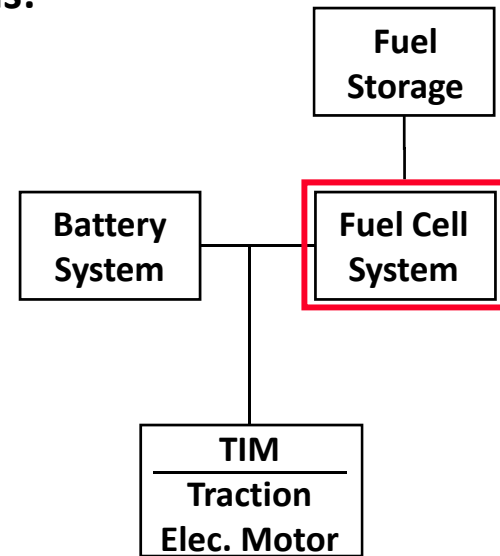

Project covers complete FC system (specifically excluding battery, traction motor/inverter, and storage)

General Rules

- **80kW_{net}** system (90 kW_{gross} for 2008 system)
- **1k to 500k** annual system production
- U.S. labor rates: **\$45/hr** (fully loaded) [previously \$60/hr]
- **\$1,100/troy oz.** Pt cost used for consistency

Some costs *NOT* included:

- **10% capital cost contingency**
- **Warranty**
- **Building costs** (equipment cost included but not building in which equipment is housed)
- **Sales Tax**
- **Non-Recurring Engineering Costs**
- **Markup for Fuel Cell Manufacturer**

DTI's DFMA[®]-Style Costing Methodology

- DFMA[®] (Design for Manufacturing and Assembly) is a registered trademark of Boothroyd-Dewhurst, Inc.
 - Used by hundreds of companies world-wide
 - Basis of Ford Motor Co. design/costing method for past 20+ years
- DTI practices are a blend of:
 - “Textbook” DFMA[®], industry standards & practices, DFMA[®] software, innovation and practicality

$$\text{Estimated Cost} = (\text{Material Cost} + \text{Processing Cost} + \text{Assembly Cost}) \times \text{Markup Factor}$$

Manufacturing rate cost factors:

1. Material Costs
2. Manufacturing Method
3. Machine Rate
4. Tooling Amortization

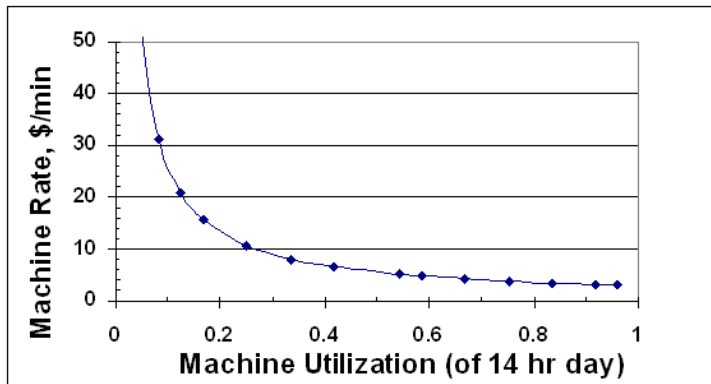

Methodology Reflects Cost of Under-utilization:

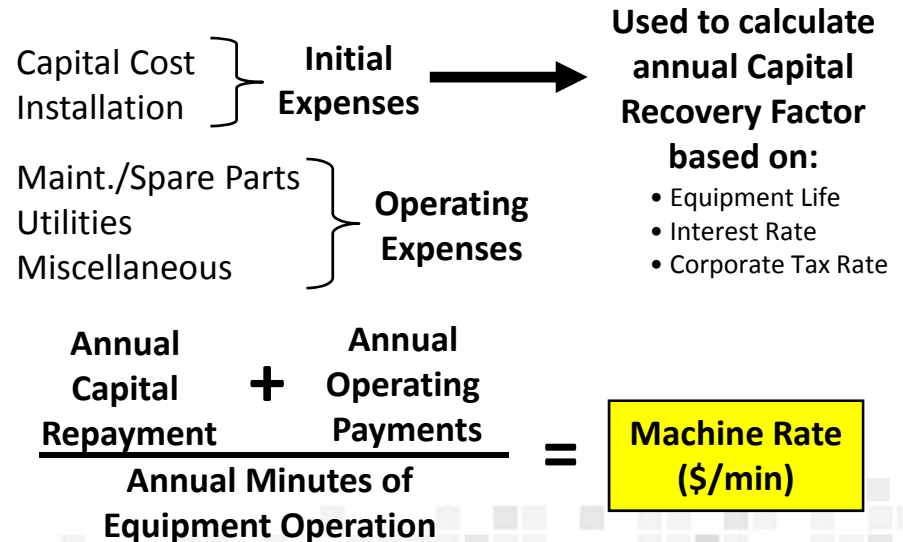

DTI's DFMA[®]-Style Costing Methodology (Cont'd)

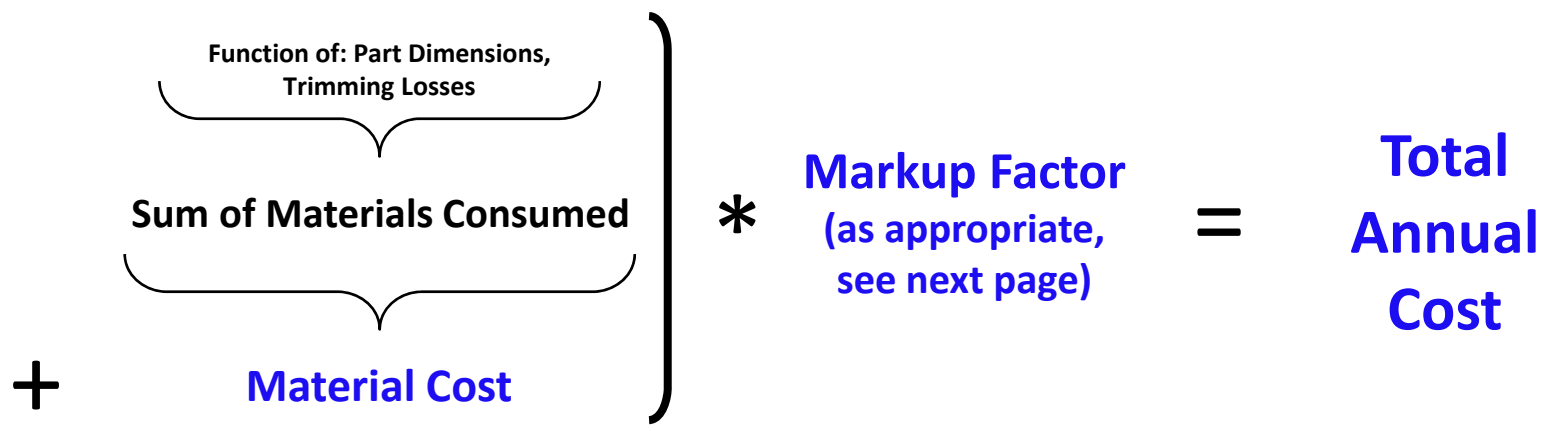
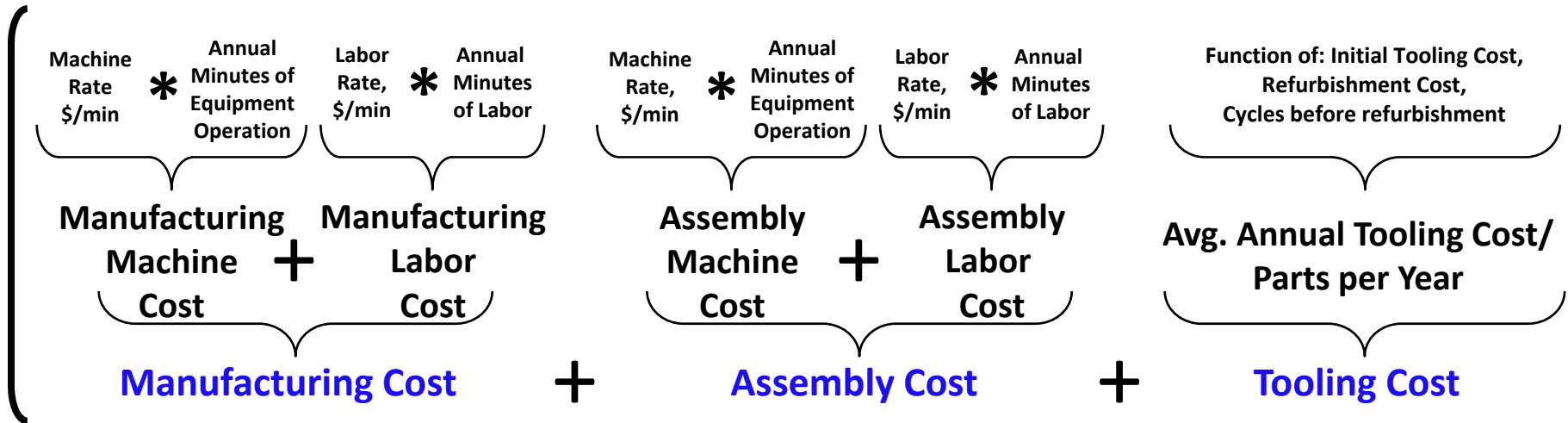

$$\text{Total Annual Cost} / \text{Units per Year} = \text{Cost per Unit}$$



Markup Basics

- **Traditional automotive “markup” Includes:**

- General & Administrative (G&A)
- Research & Development (R&D)
- Profit
- Scrap

- **Markup are applied to each step of manufacture/assembly to appropriately compensate performer for legitimate incurred costs and for adding value.**

- **Many layers of markup are incurred if part/component passes through many entities on its way to final assembly**

- Vertically integrated businesses will have fewer “markup costs” than horizontally integrated businesses

- **Different markup percentages are incurred if value is added rather than if component is just “passed through”**

Key Technical Targets Define System

		2007 Status	2008 Status	2007 Status	2008 Status	2007 Status	2008 Status
		Current (2007, 2008)		2010		2015	
DOE Tech. Targets that drive analysis:							
Stack Efficiency @ Rated Power	%	55%	55%	55%	55%	55%	55%
MEA Areal Power Density @ Peak Power	mW/cm ²	583	715	1,000	1,000	1,000	1,000
Total Pt-Group Catalyst Loading	mg PGM/cm ²	0.35	0.25	0.30	0.30	0.20	0.20
Key Derived Performance Parameters:							
System Gross Electric Power (Output)	kW	90.2	90.2	86.7	86.7	87.1	87.1
Active Area	cm ²	417	339	233	233	234	234
Cell Voltage @ Peak Power	V/cell	0.677	0.676	0.677	0.676	0.677	0.676
Operating Pressure (Peak)	atm	2.3	2.3	2.0	2.0	1.5	1.5

- A few key DOE Technical Target values are used to anchor system definition
- All other system parameters flow from DTI calculations & judgment

System Comparison

	2008 Technology	2010 Technology	2015 Technology
Power Density (mW/cm ²)	715 (was 583)	1,000	1,000
Total Pt loading (mgPt/cm ²)	0.25 (was 0.35)	0.3	0.2
Operating Pressure (atm)	2.3	2	1.5
Peak Stack Temp. (°C)	70-90	99	120
Membrane Material	Nafion on ePTFE	Advanced High-Temperature Membrane	Advanced High-Temperature Membrane
Radiator/Cooling System	Aluminum Radiator, Water/Glycol coolant, DI filter	Smaller Aluminum Radiator, Water/Glycol coolant, DI filter	Smaller Aluminum Radiator, Water/Glycol coolant, DI filter
Bipolar Plates	Stamped SS 316L with Coating	Stamped SS 316L with Coating	Stamped SS 316L with Coating
Air Compression	Twin Lobe Compressor, Twin Lobe Expander	Centrifugal Compressor, Radial Inflow Expander	Centrifugal Compressor, No Expander
Gas Diffusion Layers	Carbon Paper Macroporous Layer with Microporous layer applied on top	Carbon Paper Macroporous Layer with Microporous layer applied on top	Carbon Paper Macroporous Layer with Microporous layer applied on top
Catalyst Application	Double-sided vertical die-slot coating of membrane	Double-sided vertical die-slot coating of membrane	Double-sided vertical die-slot coating of membrane
Air Humidification	Water spray injection	Polyamide Membrane	None
H ₂ Humidification	None	None	None
Exhaust Water Recovery	SS Condenser (Liquid/Gas HX)	SS Condenser (Liquid/Gas HX)	None
MEA Containment	Injection molded LIM Hydrocarbon MEA Frame/Gasket around Hot-Pressed M&E	Injection molded LIM Hydrocarbon MEA Frame/Gasket around Hot-Pressed M&E	Injection molded LIM Hydrocarbon MEA Frame/Gasket around Hot-Pressed M&E
Coolant & End Gaskets	Laser Welding/Screen Printed Resin	Laser Welding/Screen Printed Resin	Laser Welding/Screen Printed Resin
Freeze Protection	Drain water at shutdown	Drain water at shutdown	Drain water at shutdown
H ₂ Sensors	2 for FC system 1 for passenger cabin (not in cost estimate) 1 for fuel system (not in cost estimate)	1 for FC system 1 for passenger cabin (not in cost estimate) 1 for fuel system (not in cost estimate)	None
End Plates/Compression System	Composite molded end plates with compression bands	Composite molded end plates with compression bands	Composite molded end plates with compression bands
Stack/System Conditioning	5 hours of power conditioning- from UTC's US Patent 7,078,118	4 hours of power conditioning- from UTC's US Patent 7,078,118	3 hours of power conditioning- from UTC's US Patent 7,078,118

Different Technology Schematics

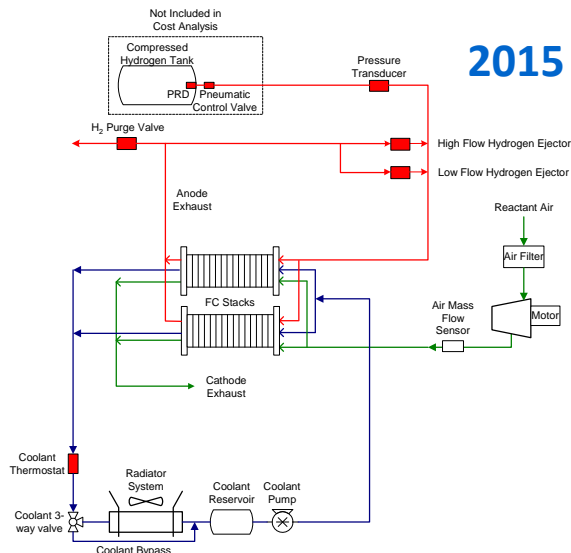
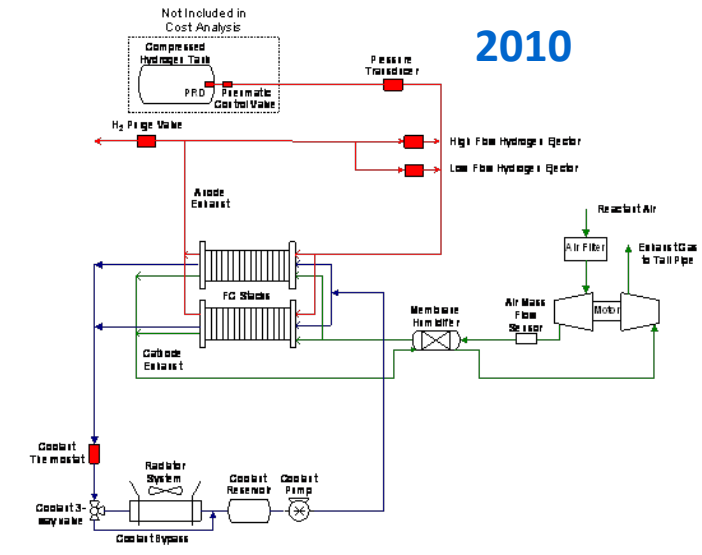
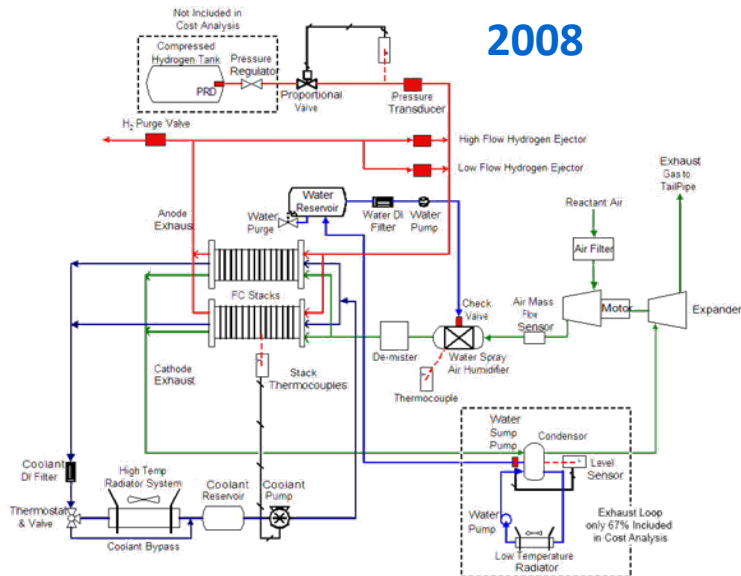

Changes from 2008 to 2010:

- Higher temperature, smaller radiator
- Use of membrane humidifier (instead of water spray)
- Lower pressure
- Centrifugal compressor/expander (instead of twin lobe compressor)

Changes from 2010 to 2015:

- Higher temperature, smaller radiator
- No humidification
- Lower pressure
- Smaller compressor
- No expander

PEM Fuel Cell Stack

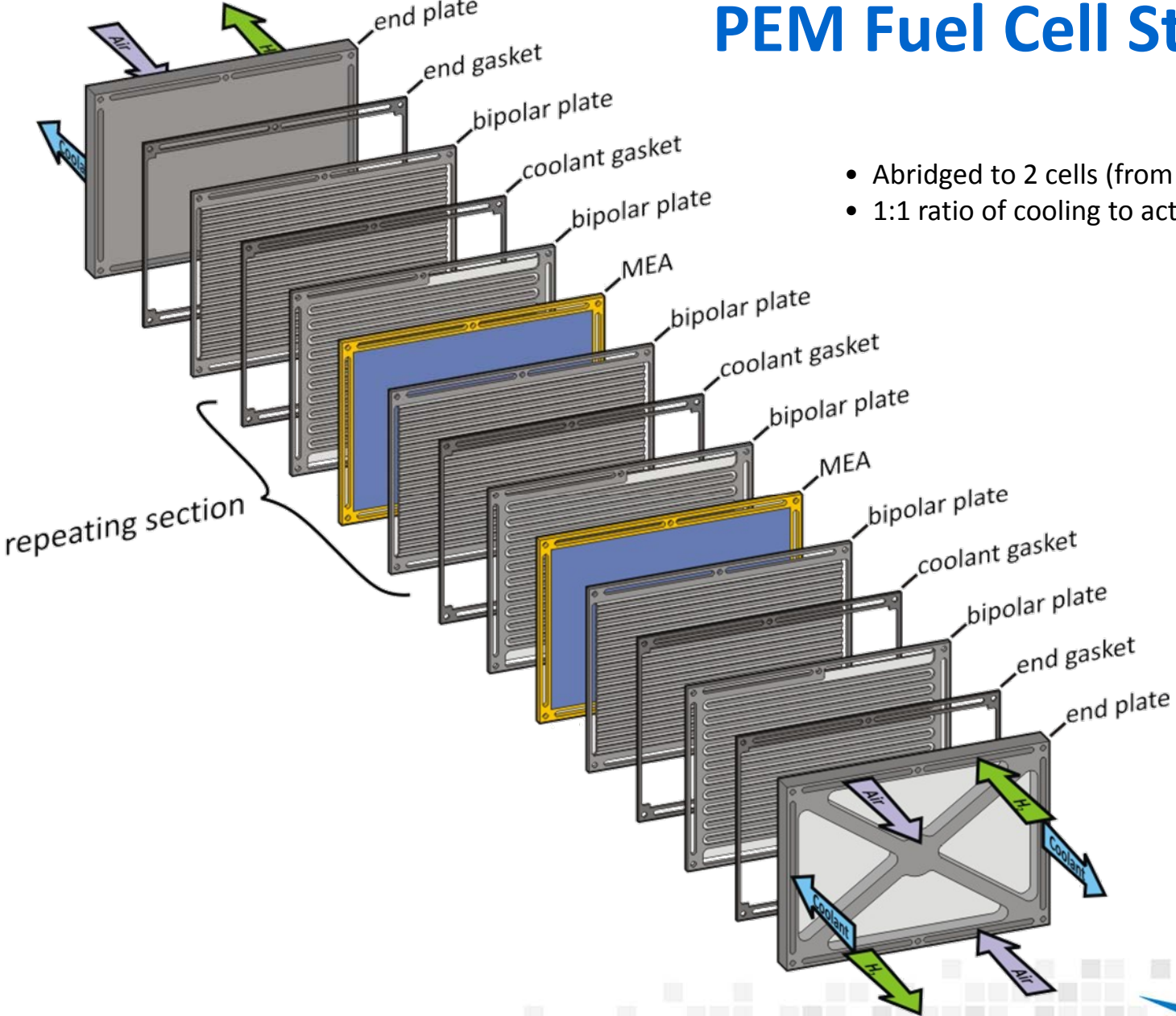

- Abridged to 2 cells (from 186) for clarity
- 1:1 ratio of cooling to active cells

Stamped Stainless Steel Bipolar Plates

- Stamped using a 4-stage Progressive Die setup
- SS 316L
- Rapid plate production (up to 80/min)
- TreadStone coating process applied to finished plates

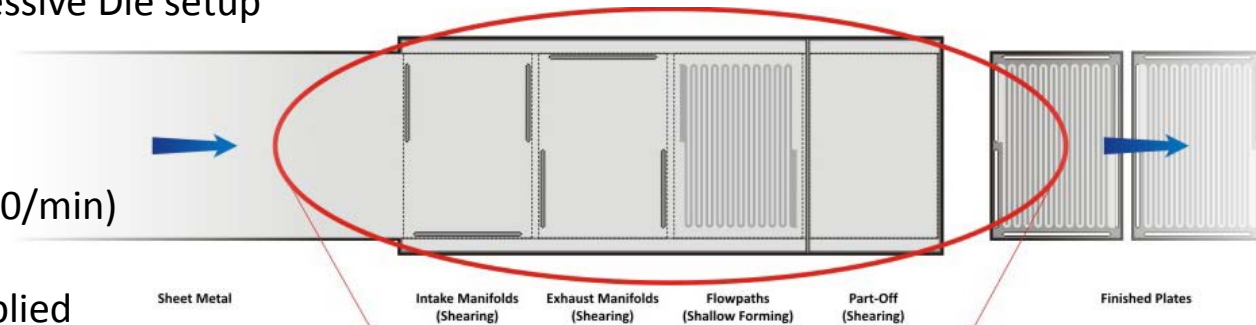

Stamped vs. other methods:

- Less brittle than composites
- Lower tooling cost than injection molding
- Lower gas permeation
- **Borderline corrosion resistance**
- **High contact resistance**

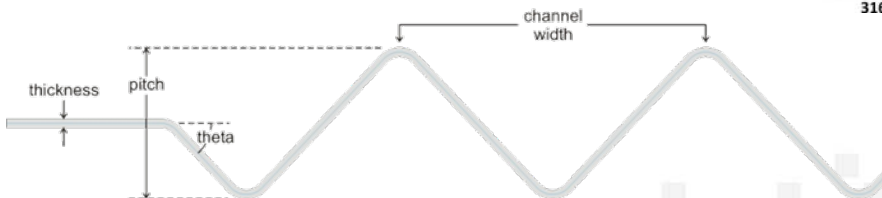
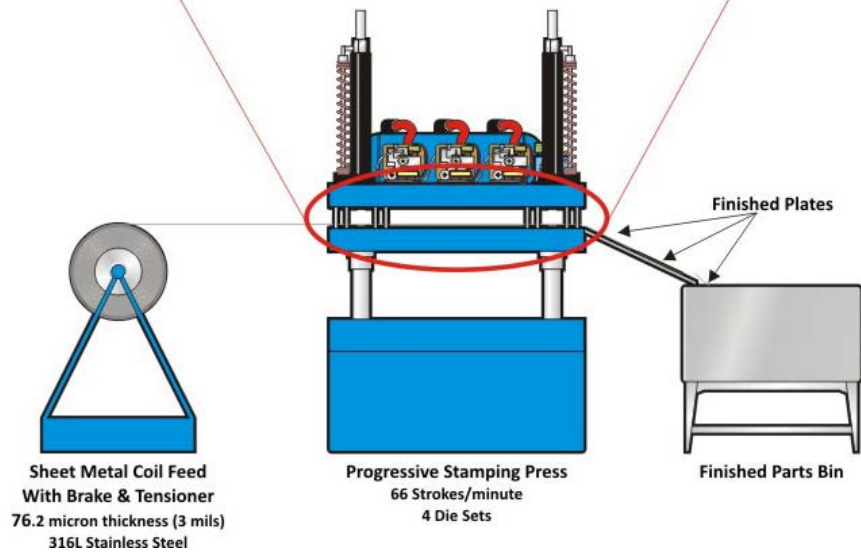

Nitrided Coatings for Stamped Bipolar Plates

Thermally Grown Cr-Nitride

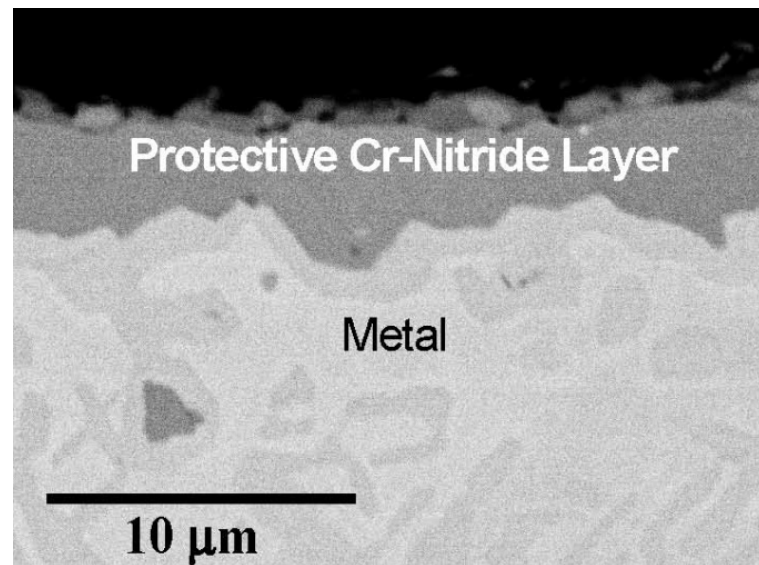

- Oak Ridge National Lab (Mike Brady) is investigating nitrided coatings for bipolar plate corrosion resistance with low surface contact resistance
- Surface conversion, not a deposited coating: High temperature favors reaction of all exposed metal surfaces
 - No pin-hole defects (other issues to overcome)
 - Amenable to complex geometries (flow field grooves)
- Conventional nitriding currently conducted in large automated facilities: anticipated process for bipolar plates is similar but simpler & faster

Nitrided Coatings for Bipolar Plates (continued)

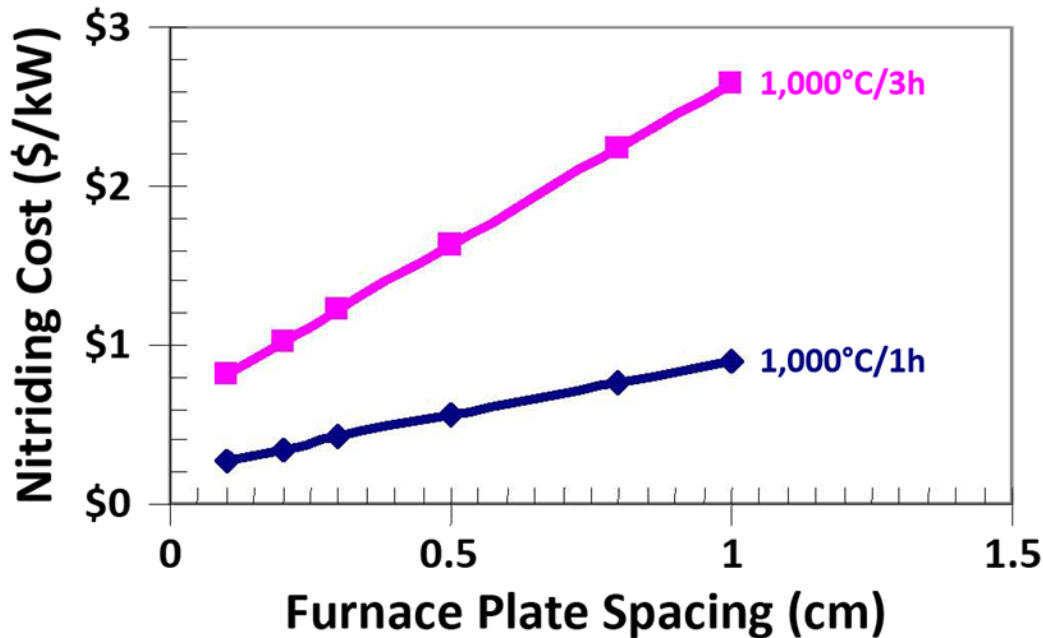

- Batch processing and automated “lights out” facilities analyzed
- Automated, step-continuous conventional nitriding system at 500,000 systems/year
 - Markup not included
 - Keys are short nitriding cycle and high furnace plate stacking density
- **\$0.75/kW potentially feasible**
- Nitriding by pulsed plasma arc lamp in range of \$0.16 - 0.44/kW
 - Feasibility to nitride Ti in “seconds” previously demonstrated

TreadStone Coatings for Stamped Bipolar Plates

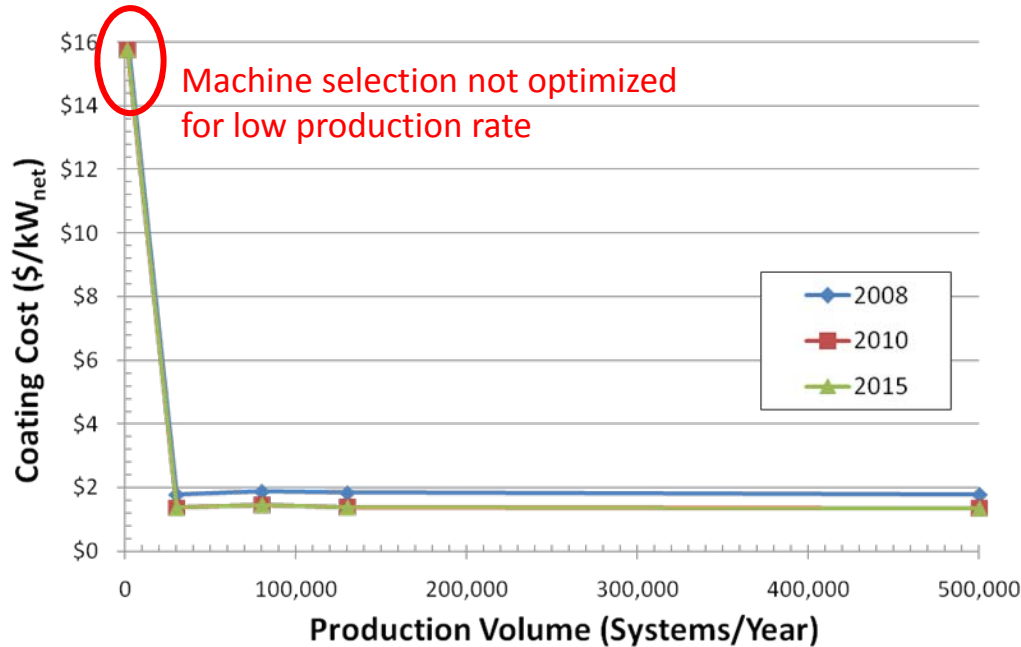

	2008	2015
316 SS Plate	\$6.34/kW _{net}	\$3.82/kW _{net}
TreadStone Coating	\$1.77/kW _{net}	\$1.34/kW _{net}
316 SS Plate (coated)	\$8.11/kW _{net}	\$5.16/kW _{net}

- Multiple coatings/treatments approaches evaluated. TreadStone LiteCell™ approach was judged to be most feasible, cost-effective, and representative of future likely approaches.
- NDA signed with TreadStone Technologies Inc., collaborated closely to model their multi-step process
- Based on US patent # 7,309,540 B2, and proprietary parameters
- Conducted in-depth evaluation based on detailed equipment manufacturer specifications
 - Machinery schematics, capital costs, machine rates, etc.
- Analyzed the impact of switching from SS 316 to the cheaper SS 304 for coated plates
 - Cost savings of SS 304 is small
 - Further savings might be achieved with cheaper plate materials such as Aluminum

Proton Exchange Membrane

(Based on Gore-like approach)

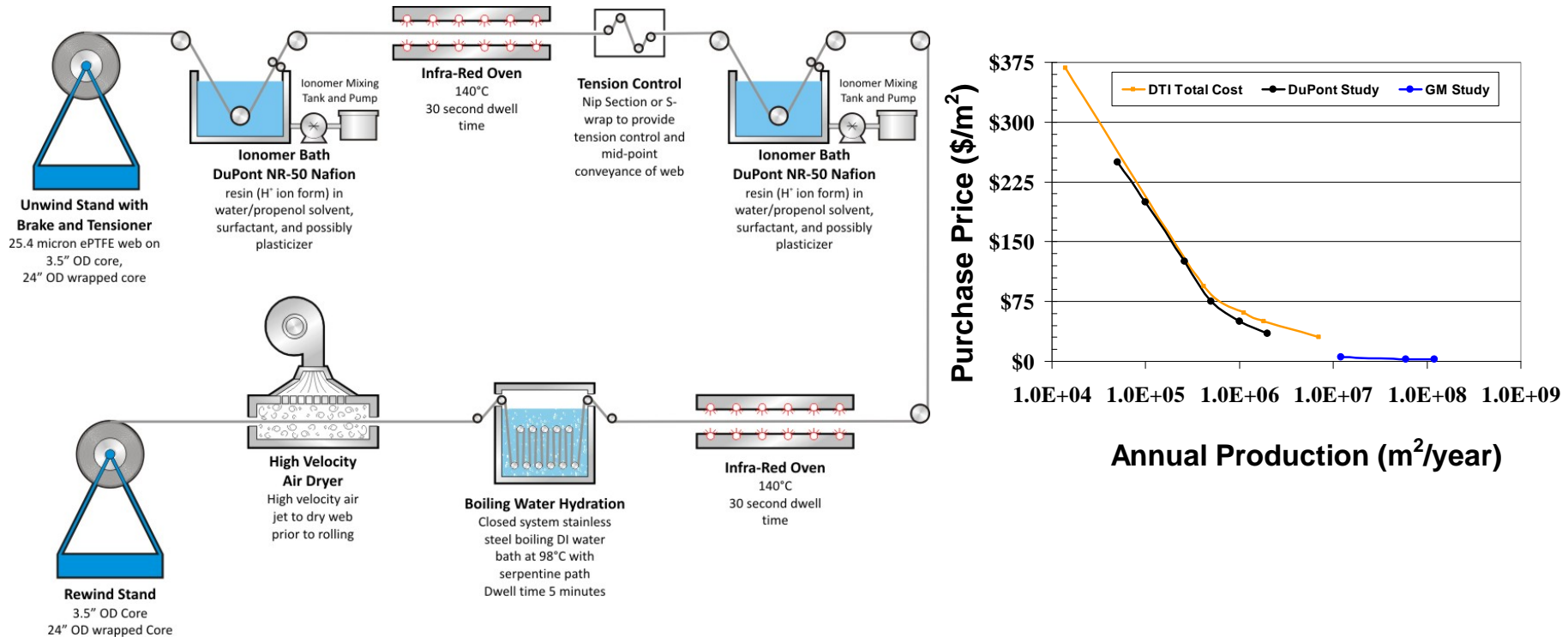

- Assumes 67% max equipment utilization consistent with 25%/year growth rate (over 5 years)
- Assumes 50%-80% membrane yields
- Membrane \$/m² is reduced solely by increases in manufacturing rate, not by technological advancement with year
- However, fewer m² are required in future years because areal power density increases

Catalyst Ink

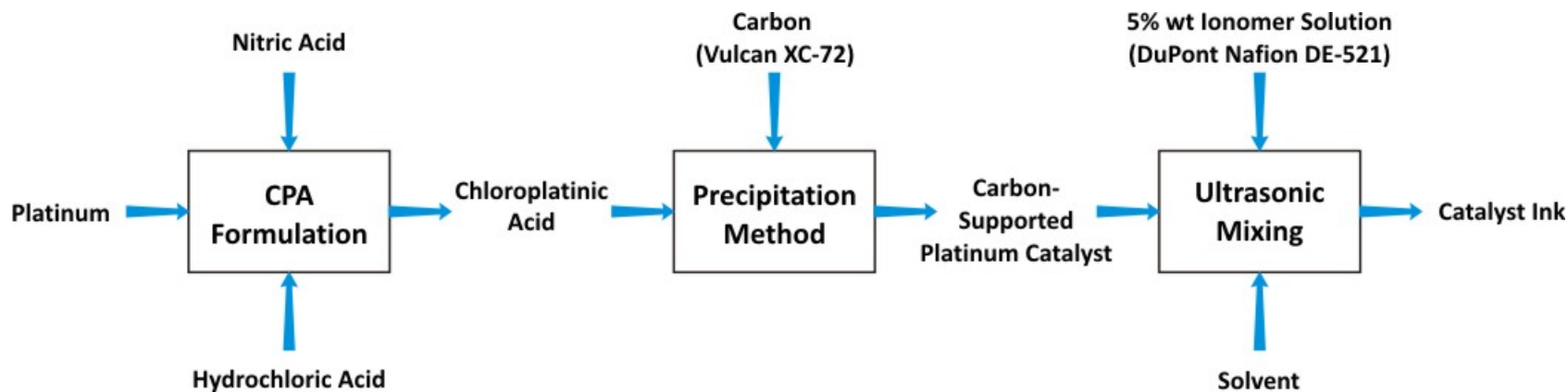

Catalyst Preparation

- Batch Pt-precipitation onto Vulcan XC-72 carbon support via a hexachloroplatinic acid (CPA) precursor (notional E-TEK-like precipitation method)

Catalyst Ink composition

- 7% (wt) Nafion Ionomer
- 15% (wt) Carbon supported Pt (40% (wt) Pt on Vulcan XC-72)
- 78% (wt) Solvent (50/50 mixture of methanol and DI water)
- Mixed Ultrasonically
- Material costs are dominated by the platinum (\$1,100/tr. oz.)

Catalyst Application

Coatema VertiCoater

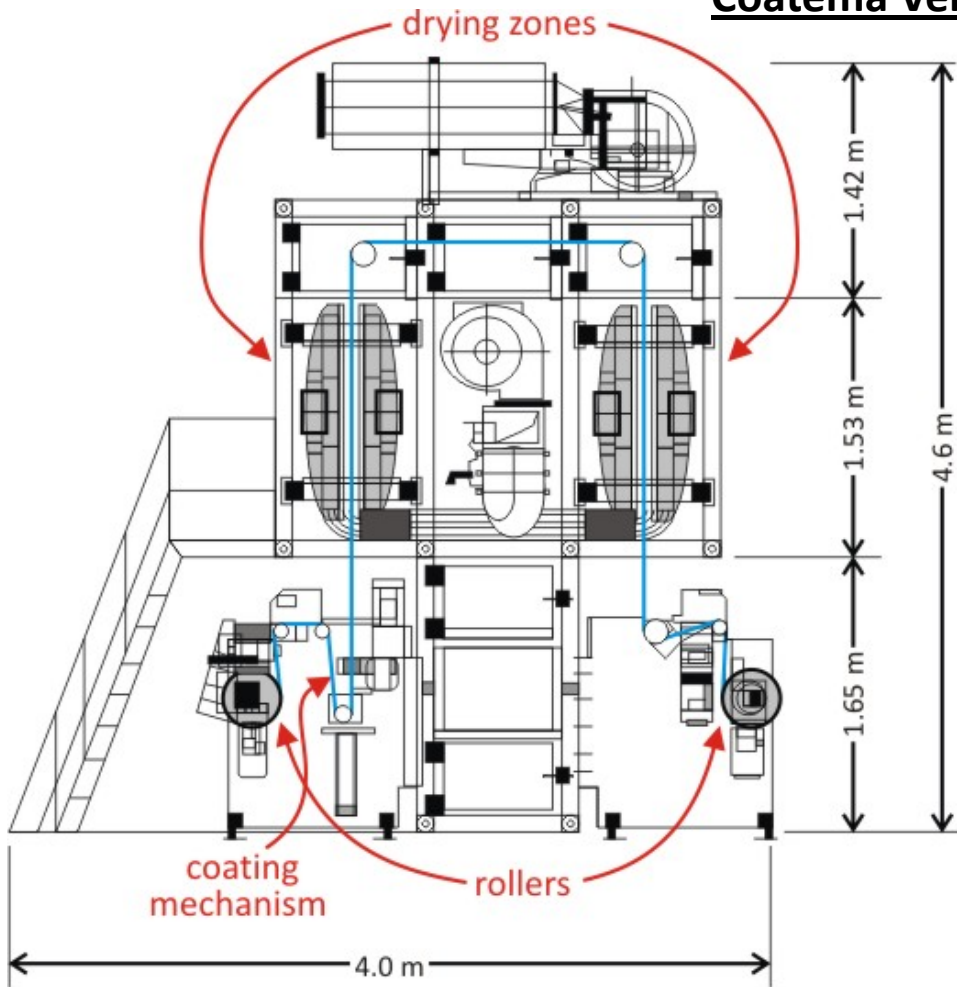

Size L/W/H: 4.0 x 1.7 x 4.6 m
Power Consumption: ~50 kW
Weight: ~4000 kg
Speed: 0.1 - 15 m/min
Roll Width: 50 - 1000 mm
Drying: Infrared 3-6 m jet dryer

- Dual-sided Vertical coating process
 - Die-slot catalyst applicator
 - Modeled as Coatema VertiCoater
- Simultaneously applies catalyst slurry to both sides of the membrane
- Maximum roll width of **1 meter**
- Line speed of **10m/min**
- **\$750,000 capital cost/line** (not counting 40% for installation)

Dual-Layer GDL Process Line

- Microporous ink mixed in ultrasonic bath
 - 12% PTFE
 - 50% Solvent
 - 38% Vulcan XC-72
- Macroporous GDL Carbon Paper based on price quote of SGL Carbon's GDL 34 BA, **\$9/m²** at high volume

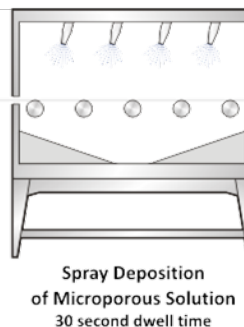
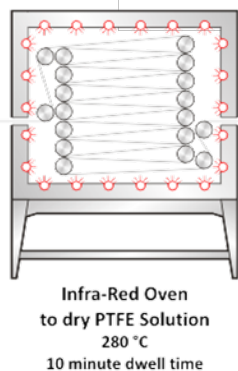
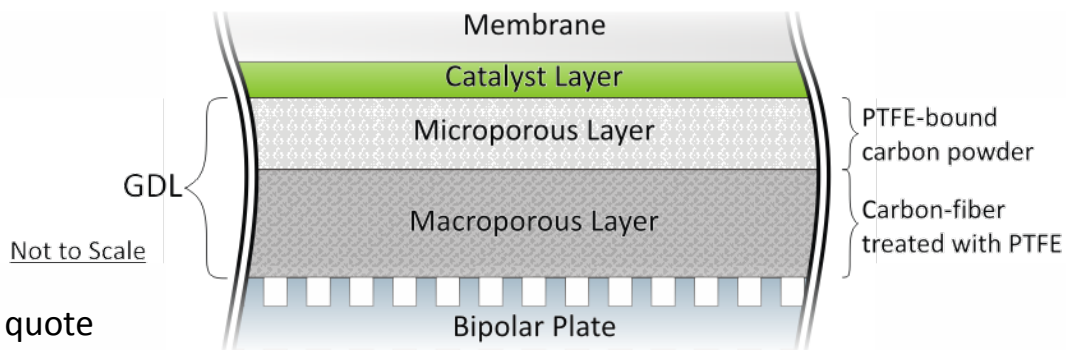

Process

- 1) Dip macroporous GDL in PTFE solution bath
- 2) Dry in oven 1
- 3) Spray apply microporous ink to macroporous substrate
- 4) Dry in oven 2
- 5) Cure in oven 3

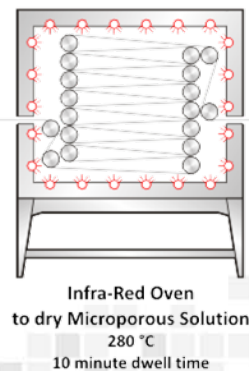
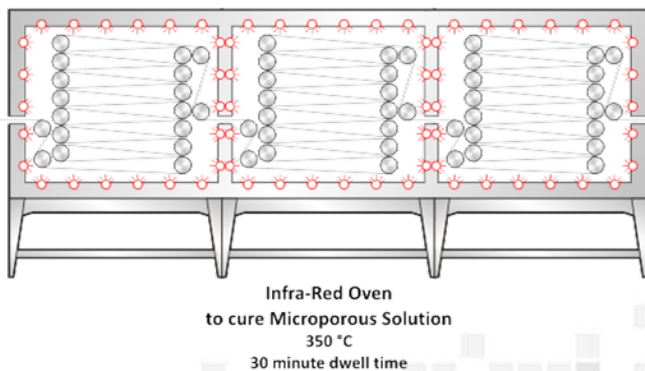

- Based on the work of Popov, et al., University of South Carolina

Indexed Hot-Pressing of MEA

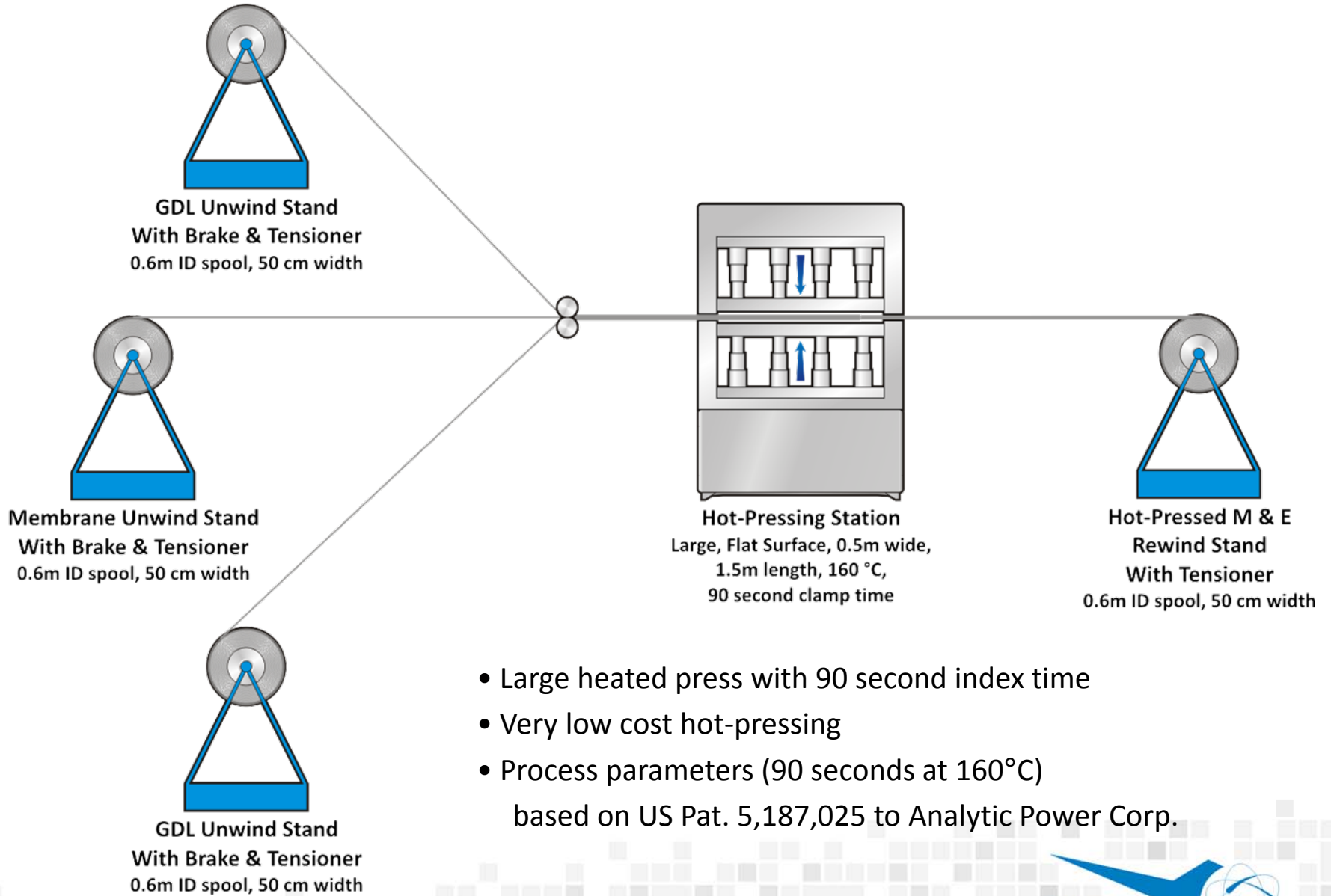

Cutting MEA to Size

- Automated conversion of hot-pressed roll-form Membranes/Electrodes into individual Membranes/Electrodes

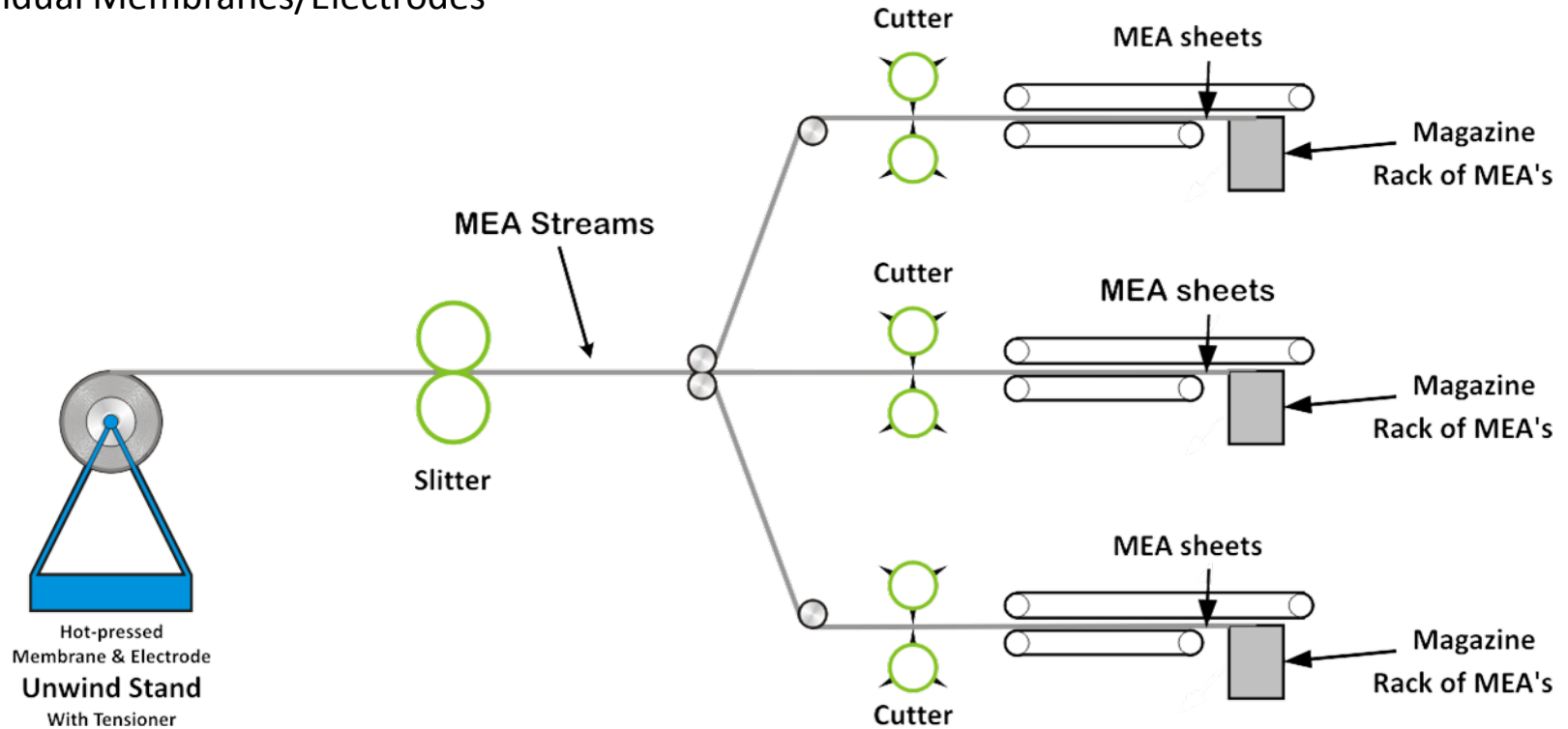

MEA Frame/Gasket

Insertion molding of gasket around MEA

Henkel Loctite Liquid Injection-Moldable (LIM) Hydrocarbon

- **\$43.37/kg** (for 500k systems/year)
- Low **1.05 g/cc** density

		Generic Silicone (2007 Analysis)	Henkel Loctite Silicone 5714	DuPont Viton® GBL-600S	DuPont Viton® GF-S	Henkel Loctite LIM Hydrocarbon
Density	g/cc	1.4	1.05	1.84	1.92	1.05
Cost	\$/kg	\$14.33	\$56.70	\$36.87	\$36.87	\$43.37
Cost	\$/L	\$20.06	\$59.54	\$67.84	\$70.79	\$45.54
Cure Time	s	150	540	420	180	60
Cure Temp	°C	127	130	177	187	130
Durability	hrs	~5,000	~5,000	~15,000	~15,000	~10,000
Inj. Mold Pressure		low	low	mid-to-high	mid-to-high	low

Red = Best in category

New Henkel Loctite material shows lots of promise

- Excellent combination of durability, low cost, and ease of manufacture

Process:

- Vacuum mixer to remove air bubbles
- **1 min** cycle time at **130°C**
- Add'l room temperature cure outside of mold
- **\$5.17/kW_{gross}** (2008 tech., 500,000 sys/year)

MEA with Integrated Seal

Ballard Patent US 7,070,876
July 4, 2006

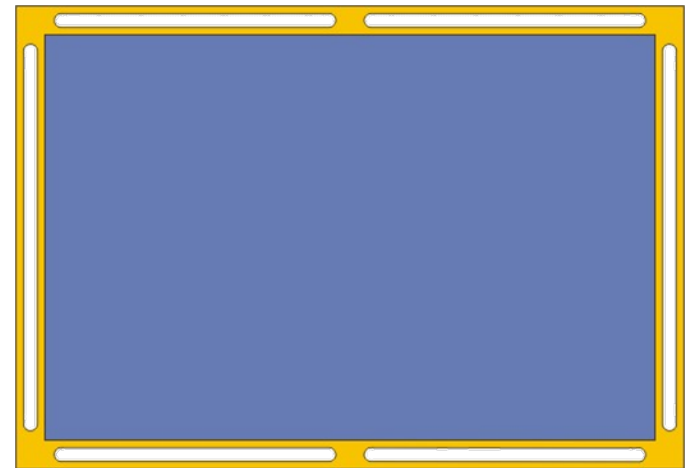
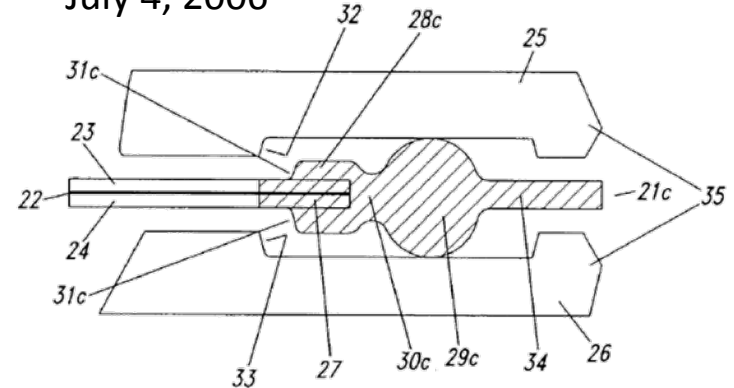

Coolant Gaskets

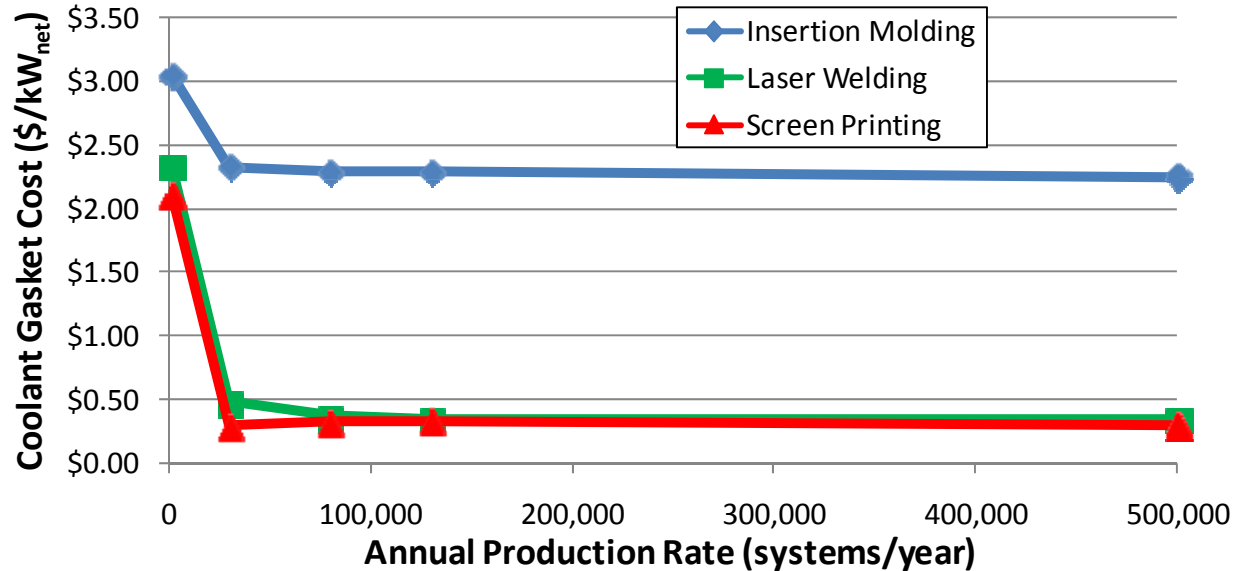

- Coolant Gasket: gasket between faces of bipolar plates that form coolant cell
- *2007 Analysis* used insertion molding for creation of coolant gaskets
- 2 new gasketing methods examined:
 - Laser Welding & Screen Printing
 - Both provide cost savings over Insertion Molding (especially with updated (higher) insertion-molded material costs)
- **Laser Welding selected**
 - Standard industry approach
 - **No material costs** (not counting consumables such as argon gas)
 - Indexed process, cycle time ranges from **2 sec** to **6 sec**, depending on machine used
 - **\$400k** process line used for 1,000 sys/year, faster **\$800k** process line used for other 4 rates
 - **\$0.31/kW_{net}** (2008 tech., 500k sys/year)

End Gaskets

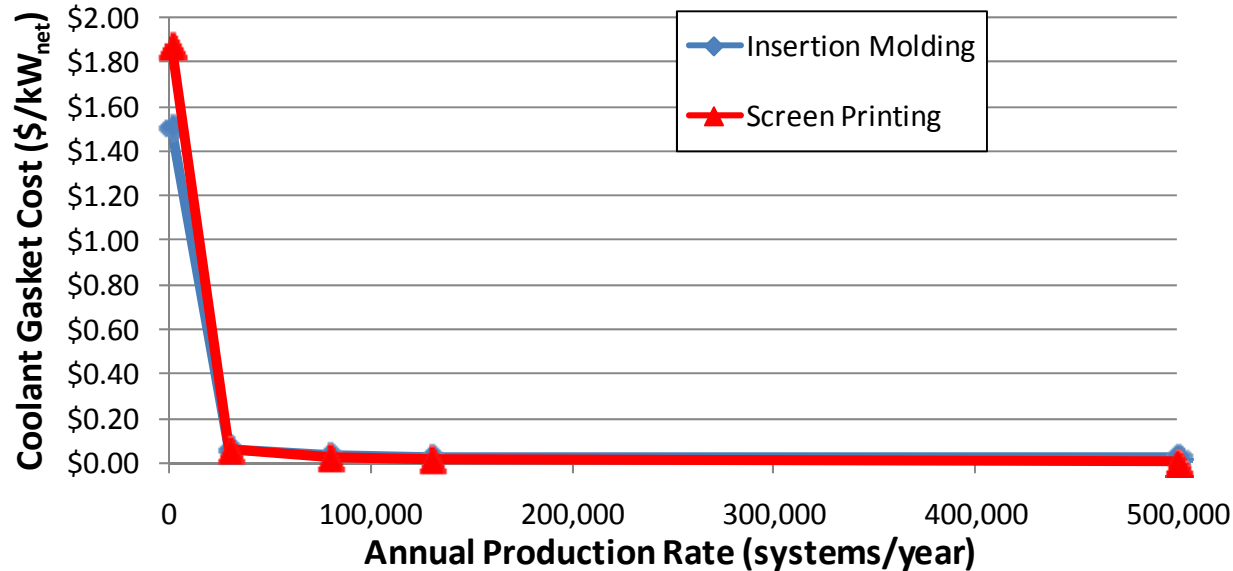

- End gaskets are similar to coolant gaskets, except:
 - They sit between the end plate & a bipolar plate and there are only 4 per system
- *2007 Analysis* used insertion molding for creation of end gaskets
- **Screen printing** method examined (welding not an option with composite end plates):
 - Provides cost savings over Insertion Molding (especially with updated (higher) insertion-molded material costs)
 - Formula-A Resin (from Dana Corp. Patent) printed onto the stainless steel bipolar plates
 - Indexed process, cycle time ranges from **9.8 sec** to **3.1 sec**, depending on machine used
 - slower **\$387k** process line used for lowest 4 rates, faster **\$638k** process line used for 500k sys/year
 - UV Curing, robotic handling
 - **\$0.01/kW_{net}** (2008 tech., 500k sys/year)

Endplates & Current Collectors

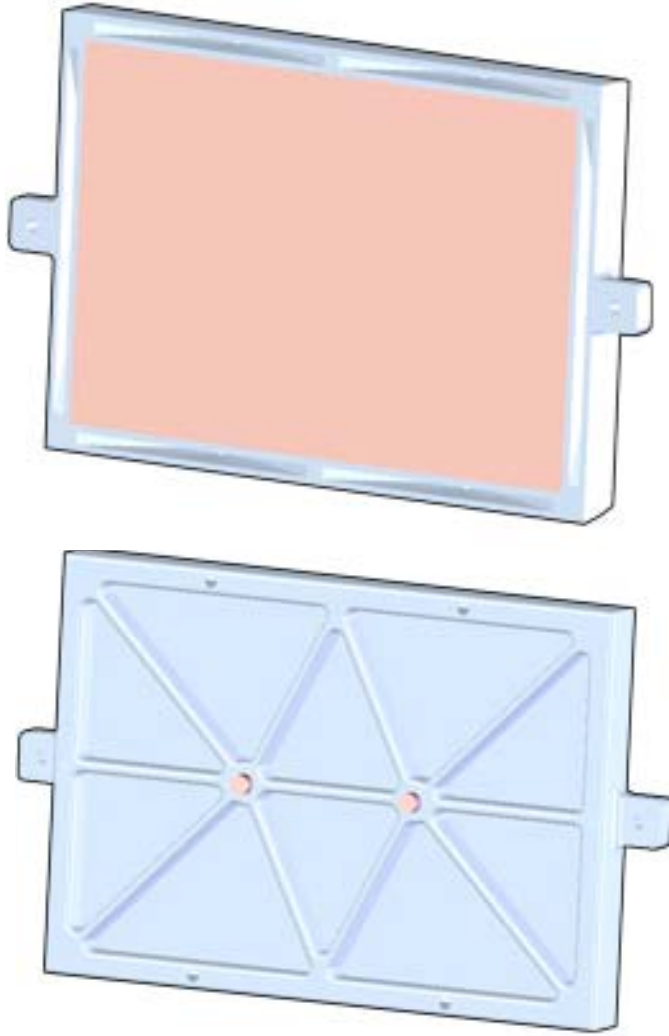

- Concept based on UTC Fuel Cells US Patent 6,764,786
- Compression molded non-conductive composite (Lytex 9063 glass fiber reinforced epoxy resin)
- Eliminates need for electrical insulators
- Provides thermal insulation
- Copper Current Collector plates are press fit into endplates with copper studs protruding through endplates for current extraction
- 5 minute cycle/cure time
- \$11-\$18/kg Lytex material cost (depending on quantity purchased)

Stack Assembly

Station 1: Assembly of stack repeat cells

Robotic assembly of stack repeat parts

Index Time: 6 seconds

Each carousel produces a "core stack" of 186 repeat cells every 9.3 minutes

=> 2 carousels working in unison produce a "core stack" every 4.65 minutes

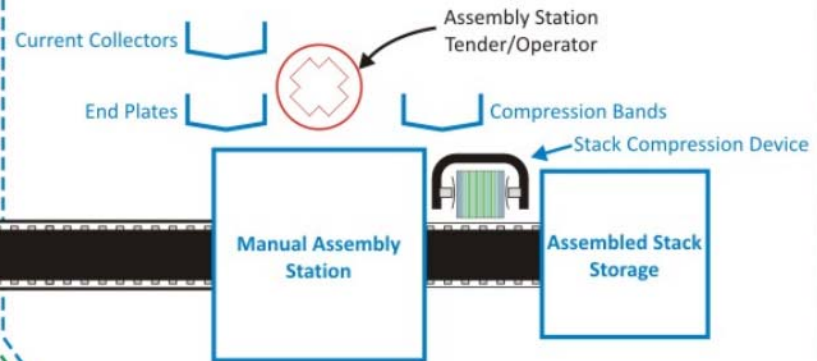
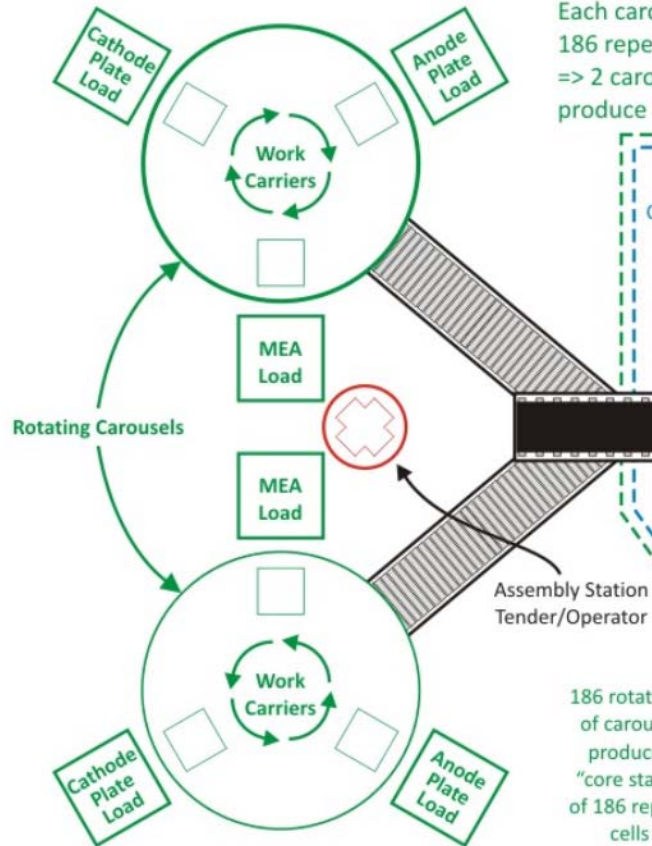

Station 2: Final stack assembly

Manual final stack assembly

Assembly work adds components to each end of the "core stacks" and attaches compression bands to complete stack assembly

186 rotations of carousel produces "core stack" of 186 repeat cells

Stack Conditioning

Step	Gas on Anode	Gas on Cathode	Primary Load Switch	DC Power Supply Positive Terminal	Electrode Potential	Current Density	
Cathode Filling Cycles	1	4% H ₂ -N ₂	N ₂	Open	Connected to Cathode	Cathode 0.04V to 1.04V	Low
	2	4% H ₂ -N ₂	N ₂	Open	Connected to Cathode	Cathode 0.04V to 1.04V	Low
	3	Repeat Step #1					Low
	4	Repeat Step #2					Low
	5	Repeat Step #1					Low
	6	Repeat Step #2					Low
Anode Filling Cycles	7	N ₂	4% H ₂ -N ₂	Open	Connected to Anode	Anode 0.04V to 1.04V	Low
	8	N ₂	4% H ₂ -N ₂	Open	Connected to Anode	Anode 0.04V to 1.04V	Low
	9	Repeat Step #7					Low
	10	Repeat Step #8					Low
	11	Repeat Step #7					Low
	12	Repeat Step #8					Low
Performance Calibrations	13	H ₂	Air	Closed	Not Connected	Depends on Current Density	0-1600 mA/cm ²
	14	Repeat step #13 up to 10 times					

- Stacks “conditioned” for enhanced performance
- Based on UTC Fuel Cells Patent US 7,078,118
- Stacks condition per “Applied Voltage Embodiment”
- 10 stacks conditioned simultaneously
- Load bank capital cost **~\$100k**
- Conditioning of stacks staggered to limit peak testing load to ~50kW
- Stacks conditioned to achieve 95% of max performance (**~5 hrs**; max performance requires ~13 hrs)

Stack Component Cost Distribution

1,000 systems (2008)

1,000 systems (2010)

1,000 systems (2015)

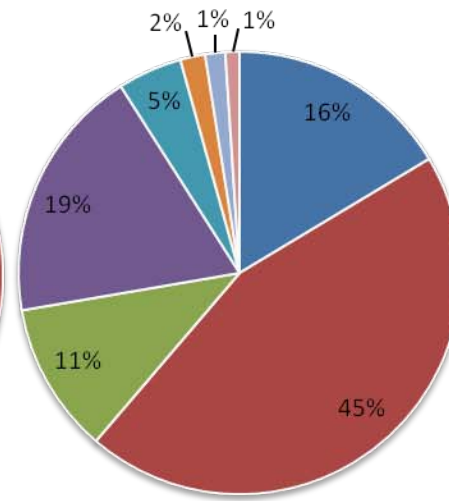
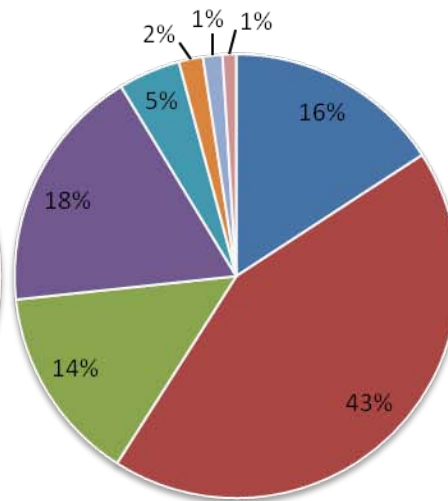
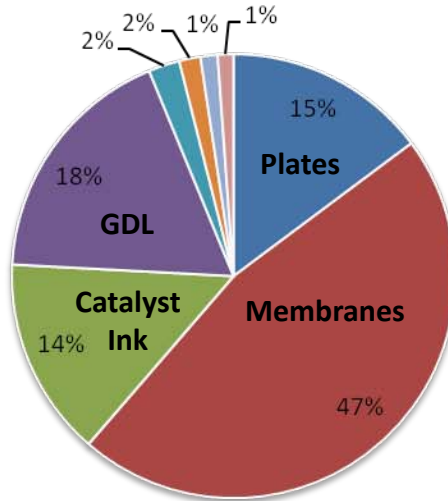

500,000 systems (2008)

500,000 systems (2010)

500,000 systems (2015)

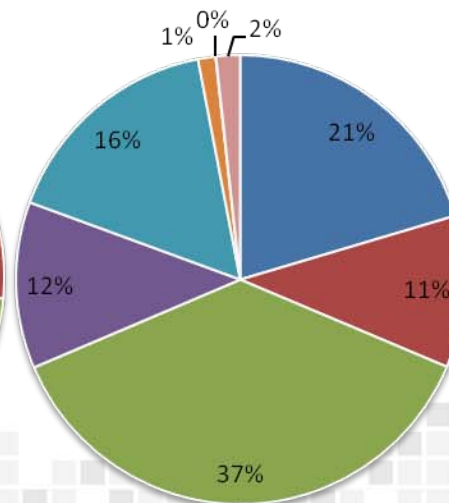
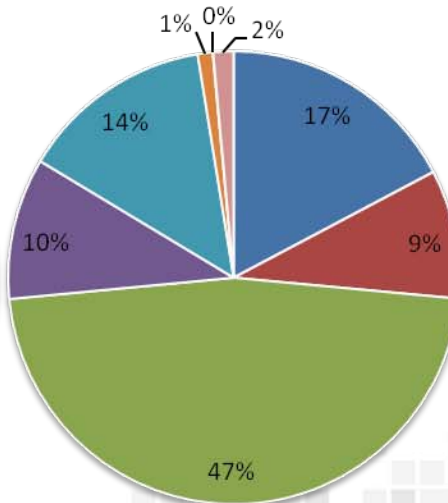
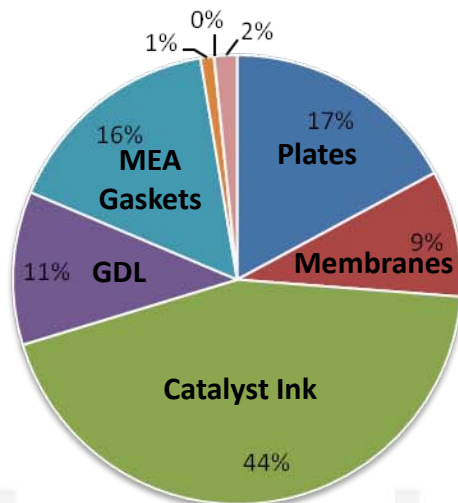

- Bipolar Plates (Stamped)
- Membranes
- Catalyst Ink & Application
- GDLs
- MEA Frame/Gaskets
- Coolant Gaskets (Laser Welding)
- End Gaskets (Screen Printing)
- End Plates

- Membrane dominates cost at low production
- Catalyst Ink dominates cost at high production
- Top 3 costs:
 - Membrane
 - Catalyst Ink
 - GDL

Platinum Cost

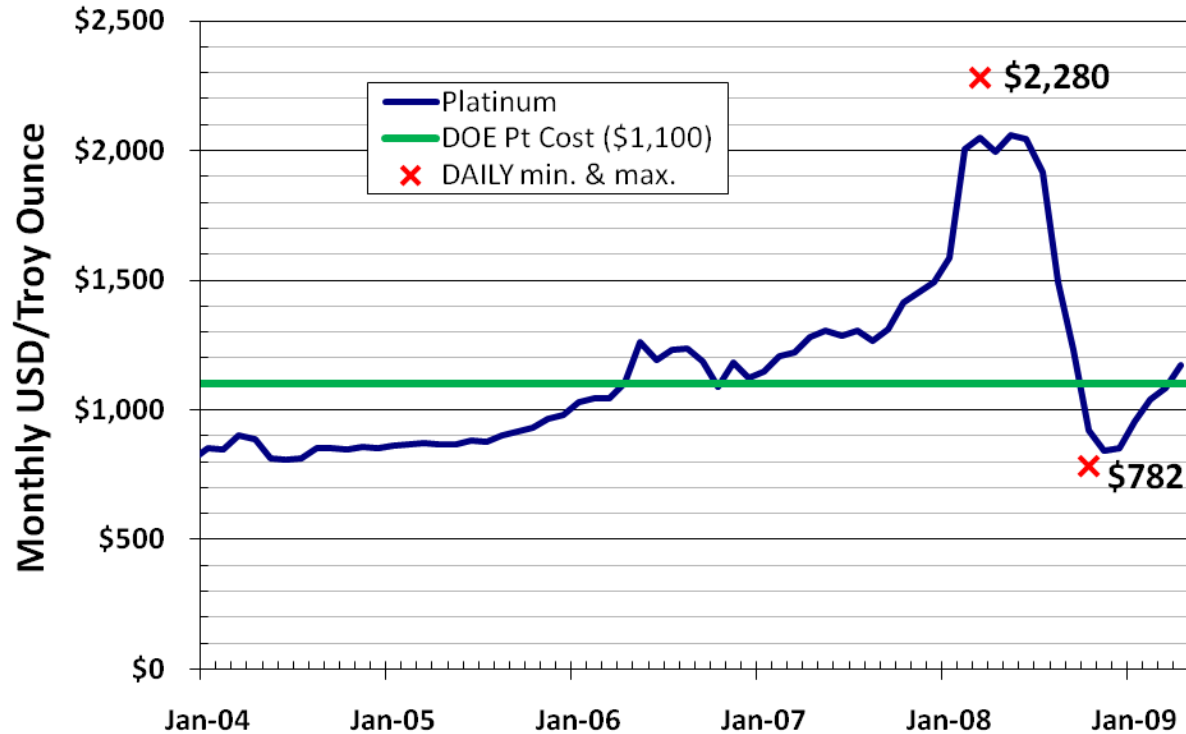

- Currently trading at ~\$1,118/tr.oz. (7/8/2009)
- Platinum cost is highly variable:
 - 3/04/08: \$2,280/tr.oz.
 - 10/27/08: \$782/tr.oz.
- Consistent use of \$1,100 facilitates “apples-to-apples” system costs comparison
- Especially for the current technology system, Pt is a major system cost component, so estimates are highly susceptible to Pt cost fluctuations

Hydrogen Sensors

- Makel Engineering sensors
 - Better, cheaper technology than in 2007 system

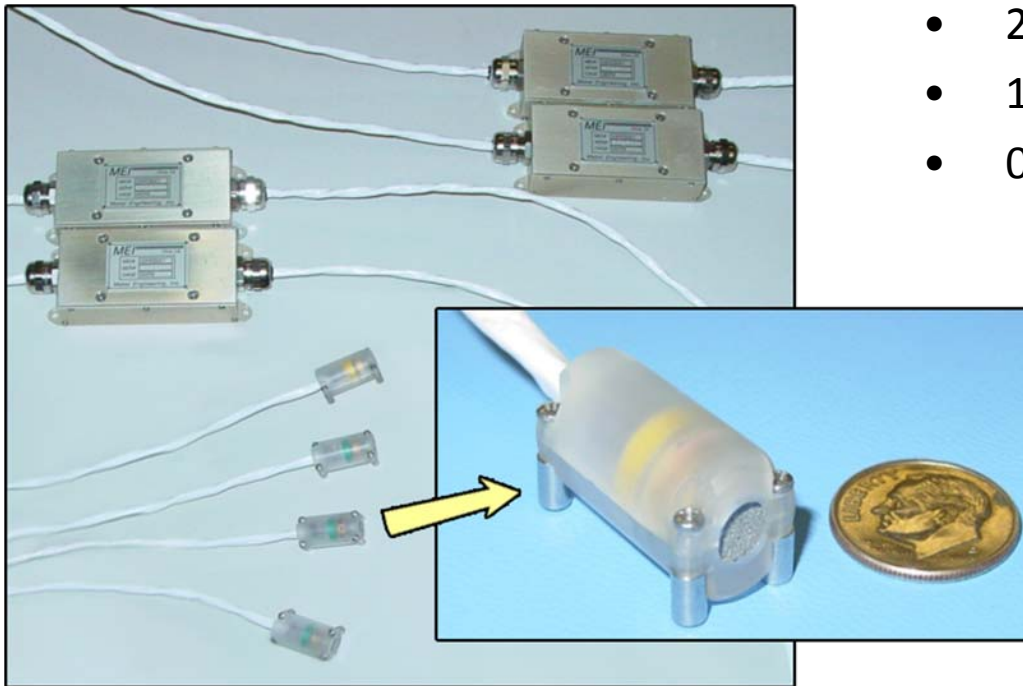

- 2 sensors/system at 2008 tech.
- 1 per system for 2010 tech.
- 0 per system for 2015 tech.

- **\$850/sensor** vs. \$2000 in '07 Analysis
 - 1k sys/year, 2008 tech.
- **\$100/sensor** vs. \$150 in '07 Analysis
 - 500k sys/year, 2008 tech.

Belly Pan

		Annual Production Rate	1,000	30,000	80,000	130,000	500,000
2008 Analysis	2008	Materials (\$/system)	\$3.88	\$3.88	\$3.88	\$3.88	\$3.88
		Manufacturing (\$/system)	\$22.47	\$1.65	\$1.31	\$0.88	\$0.35
		Tooling (\$/system)	\$39.91	\$1.33	\$0.44	\$0.27	\$0.07
		Total Cost (\$/system)	\$66.27	\$6.87	\$5.64	\$5.04	\$4.30
		Total Cost (\$/kW_{net})	\$0.83	\$0.09	\$0.07	\$0.06	\$0.05
		2010	Materials (\$/system)	\$3.88	\$3.88	\$3.88	\$3.88
	Manufacturing (\$/system)		\$22.47	\$1.65	\$1.31	\$0.88	\$0.35
	Tooling (\$/system)		\$39.91	\$1.33	\$0.44	\$0.27	\$0.07
	Total Cost (\$/system)		\$66.27	\$6.87	\$5.64	\$5.04	\$4.30
	Total Cost (\$/kW_{net})		\$0.83	\$0.09	\$0.07	\$0.06	\$0.05
	2015		Materials (\$/system)	\$3.88	\$3.88	\$3.88	\$3.88
		Manufacturing (\$/system)	\$22.47	\$1.65	\$1.31	\$0.88	\$0.35
Tooling (\$/system)		\$39.91	\$1.33	\$0.44	\$0.27	\$0.07	
Total Cost (\$/system)		\$66.27	\$6.87	\$5.64	\$5.04	\$4.30	
Total Cost (\$/kW_{net})		\$0.83	\$0.09	\$0.07	\$0.06	\$0.05	
2007 Analysis		2007	Total Cost (\$/system)	\$400.12	\$41.12	\$17.58	\$12.18
	Total Cost (\$/kW_{net})		\$5.00	\$0.51	\$0.22	\$0.15	\$0.07
	2010	Total Cost (\$/system)	\$219.04	\$29.19	\$13.09	\$9.38	\$5.02
		Total Cost (\$/kW_{net})	\$2.74	\$0.36	\$0.16	\$0.12	\$0.06
	2015	Total Cost (\$/system)	\$219.66	\$29.27	\$13.12	\$9.40	\$5.02
		Total Cost (\$/kW_{net})	\$2.75	\$0.37	\$0.16	\$0.12	\$0.06

- New bottom-up DFMA analysis
- Vacuum thermoforming process
- Polypropylene, **\$1.15/kg**
- Manual Loading used at all mfg. rates except 500k/year
- **\$0.05/kW_{net}** (500k/year)

Wiring

- New bottom-up analysis
 - Detailed wiring requirements & BOM
 - Vendor quotes on wires/connectors
- Analysis only covers materials costs
(installation covered in system assembly)

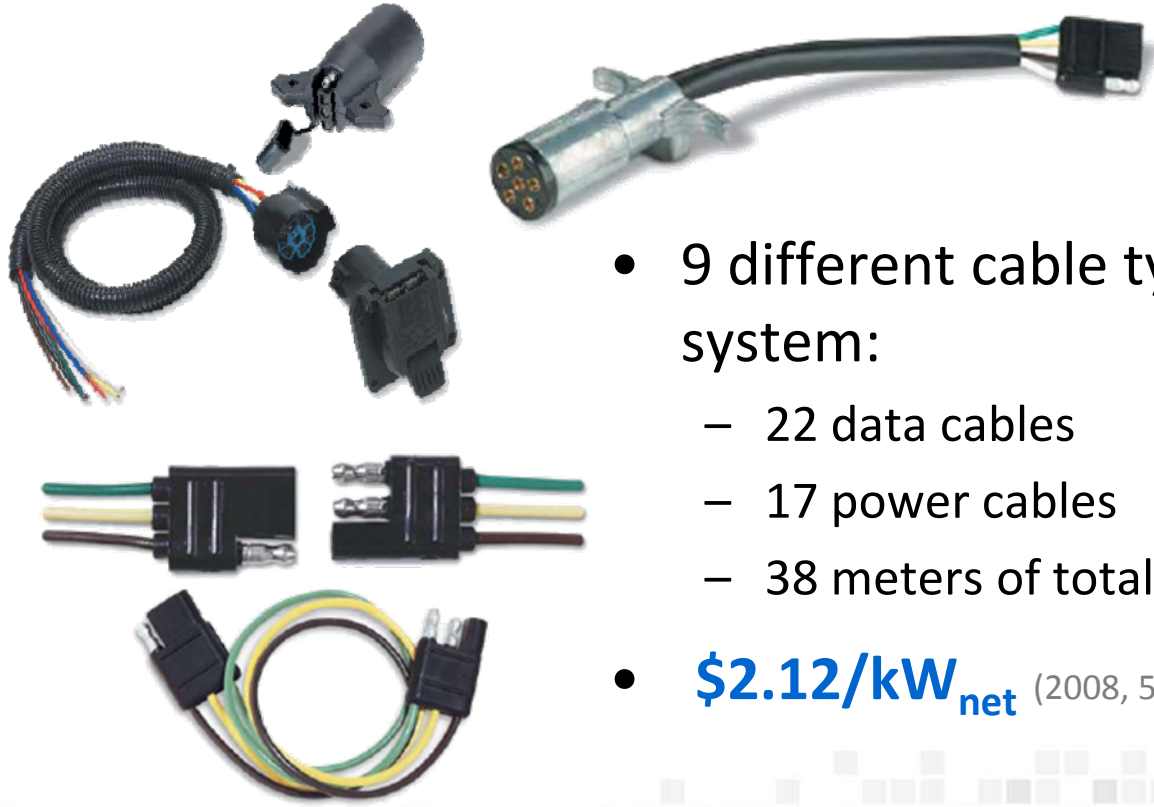

- 9 different cable types in each system:
 - 22 data cables
 - 17 power cables
 - 38 meters of total length
- **\$2.12/kW_{net}** (2008, 500k sys/year)



CMEU Cost Study with Honeywell

- CMEU = Compressor-Motor-Expander Unit
- CMEU has a large impact on the total system cost:
 - **10.3%** of system cost (2008, 500k systems/year)
 - **11.4%** of gross power (2008, 500k systems/year)
- Partnering with Honeywell to determine a detailed CMEU cost for each of two existing designs, plus the associated control electronics:
 - Turbocompressor/motor unit for ~2 atm fuel cell operation
 - Supercharger unit for ~1.5 atm fuel cell operation
- Honeywell is providing detailed cost breakdowns based largely on vendor quotes for detailed CAD drawings
- DTI is developing a new DFMA model for CMEU
- DTI & Honeywell will analyze designs for possible cost-saving improvements
- Results will go into 2009 system analysis

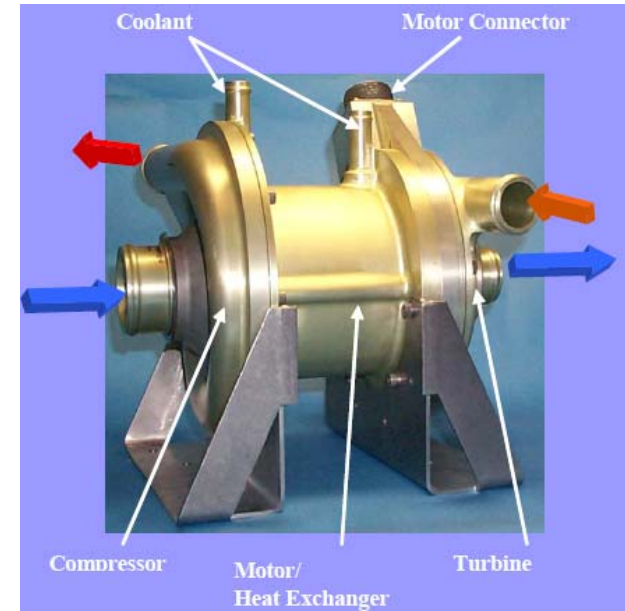

System Assembly

	Number of Components	Component Placement Time (sec)	Component Fixation Time (sec)	Component Totals (min)
Major Components (Stack, Motors, Pumps, Vessels, etc.)	19	45	60	33.3
Minor Components (Instruments, Devices, etc.)	22	30	45	27.5
Piping				
# of Pipe Segments		5		
Bends per Segment		2		
Time per Bend		0		
Pipe Placement Time		30		
# of Welds per Pipe		2		
Weld Time		90		
# of Threaded Ends per Pipe		0		
Threading Time		0		17.5
Hoses	21	30	105	47.3
Wiring (manual)	23	41.8	66.7	41.6
System Basic Functionality Test				10.0
Total System Assembly Time				177.1

- Detailed DFMA not conducted
- Approximate assembly time: **3 hrs/system**
- Bill of Materials (BOM) components divided into 5 main categories and a notional installation time was attributed to each.
- Full manual assembly used for 1,000/yr manufacturing rate.
- 10-station assembly line used for all other rates

Balance of Plant

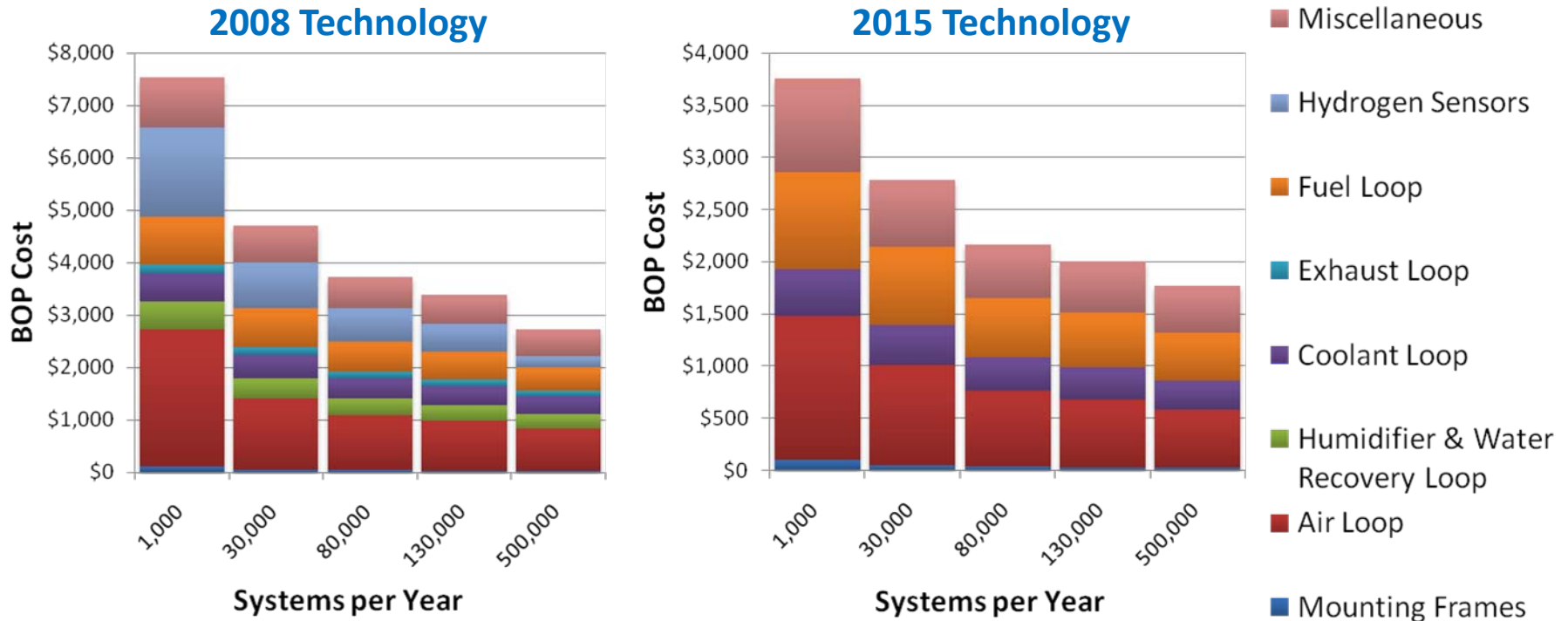

- Increases in manufacturing rate leads to largest savings.
- Air Compressors and Sensors are the two categories that have the largest \$ decline, together yielding 70% of the BOP cost decline from low production to high production.

- Technology changes yields lesser BOP savings and comes in form of reduced/eliminated components.
- Simplifications of Air, Humidifier, & Coolant Loops yield majority of technology improvement savings.

Stack & System Costs vs. Annual Production Rate

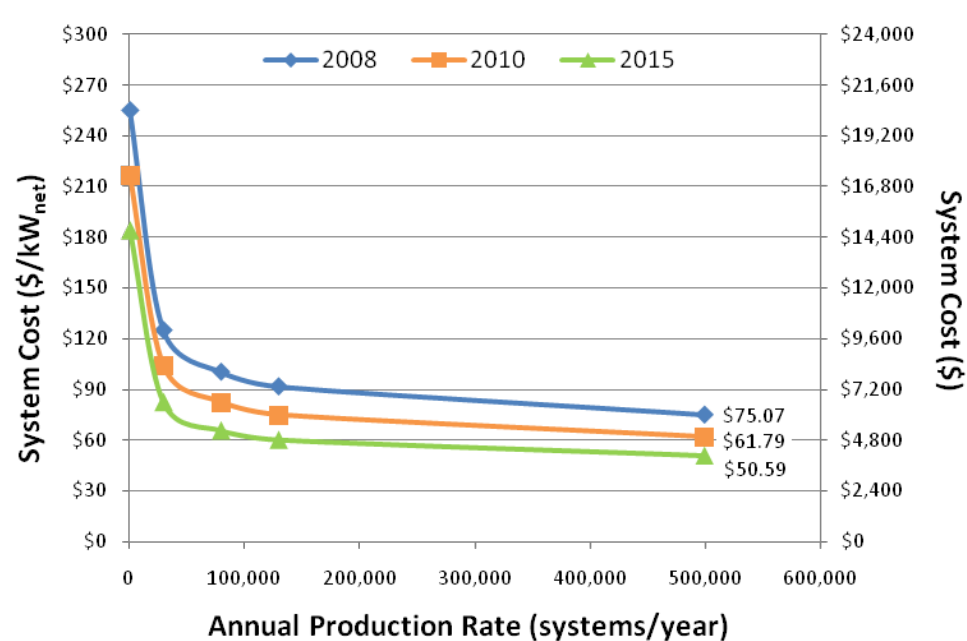
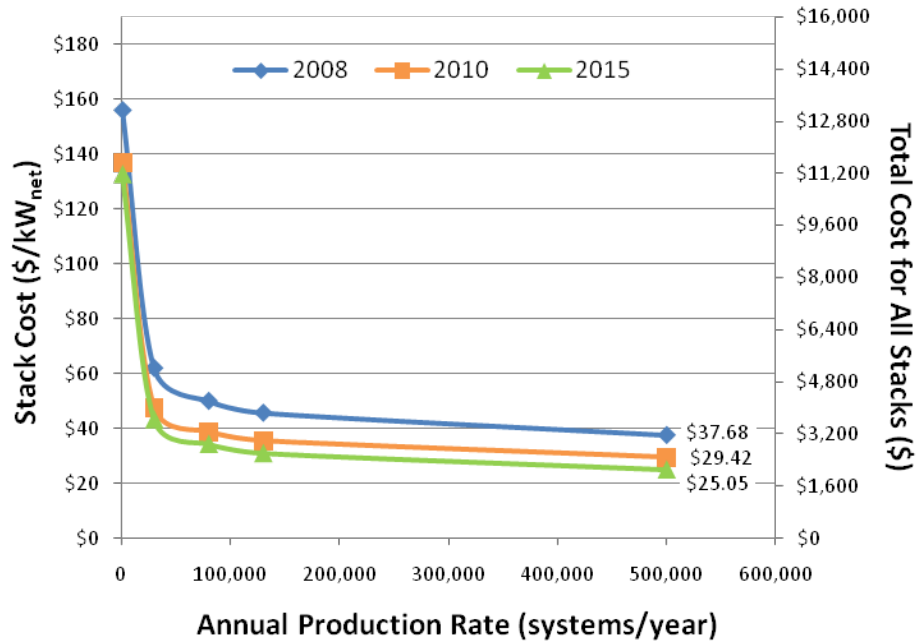

- Power Density = **715 mW/cm²**
- Catalyst Loading = **0.25 mgPt/cm²**

			2007 Status	2008 Status	2007 Status	2008 Status	2007 Status	2008 Status
			Current (2007, 2008)		2010		2015	
DOE Target:	Stack Cost	\$/kW _{e (net)}	-	-	\$25	\$25	\$15	\$15
Study Estimate:	Stack Cost	\$/kW _{e (net)}	\$50	\$38	\$27	\$29	\$23	\$25
DOE Target:	System Cost	\$/kW _{e (net)}	-	-	\$45	\$45	\$30	\$30
Study Estimate:	System Cost	\$/kW _{e (net)}	\$94	\$75	\$66	\$62	\$53	\$51

Sensitivity Analysis

System Cost (\$/kW_{net}): 2008 Technology, 500,000 systems/year

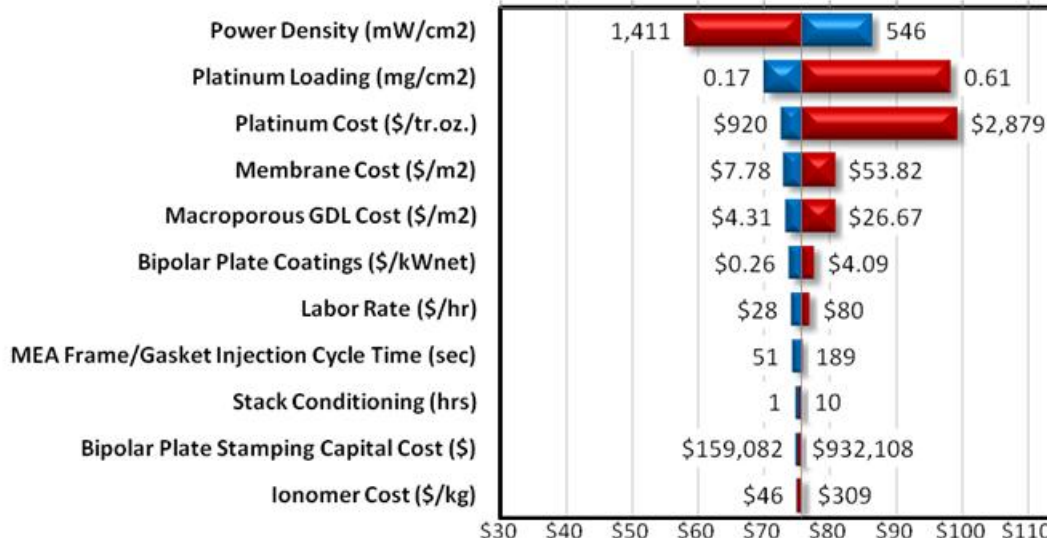

- **Power density, Platinum Loading, and Platinum cost** are by far the three largest elements of cost uncertainty

- In the 2015 system, the platinum doesn't have as much effect due to the higher assumed power density.

System Cost (\$/kW_{net}): 2010 Technology, 500,000 systems/year

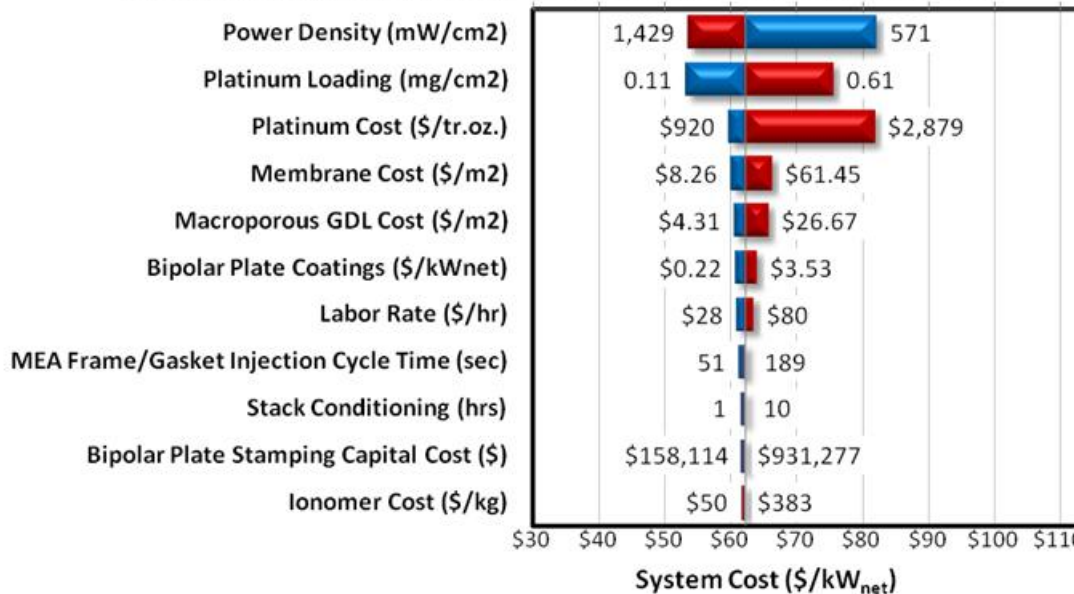

- Uncertainties in **Stack conditioning** and **Bipolar plate stamping cost** have negligible effect on the total system cost.

Progress in the Analysis

Over the last three years of analysis:

The current technology cost projection has dropped by **29%** (at 500,000 sys/year) due to a combination of technology improvement and analysis refinement

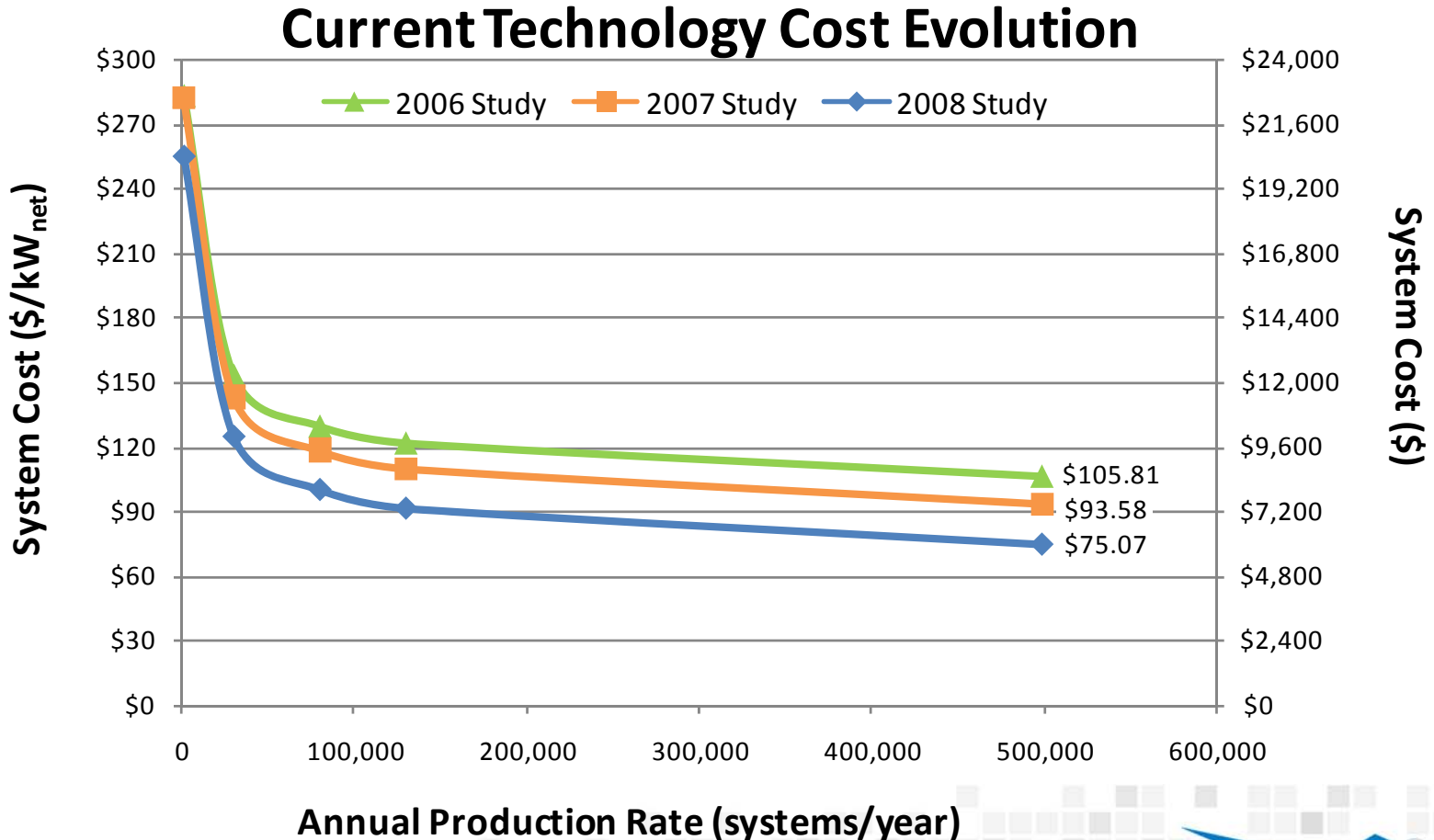

Future Work

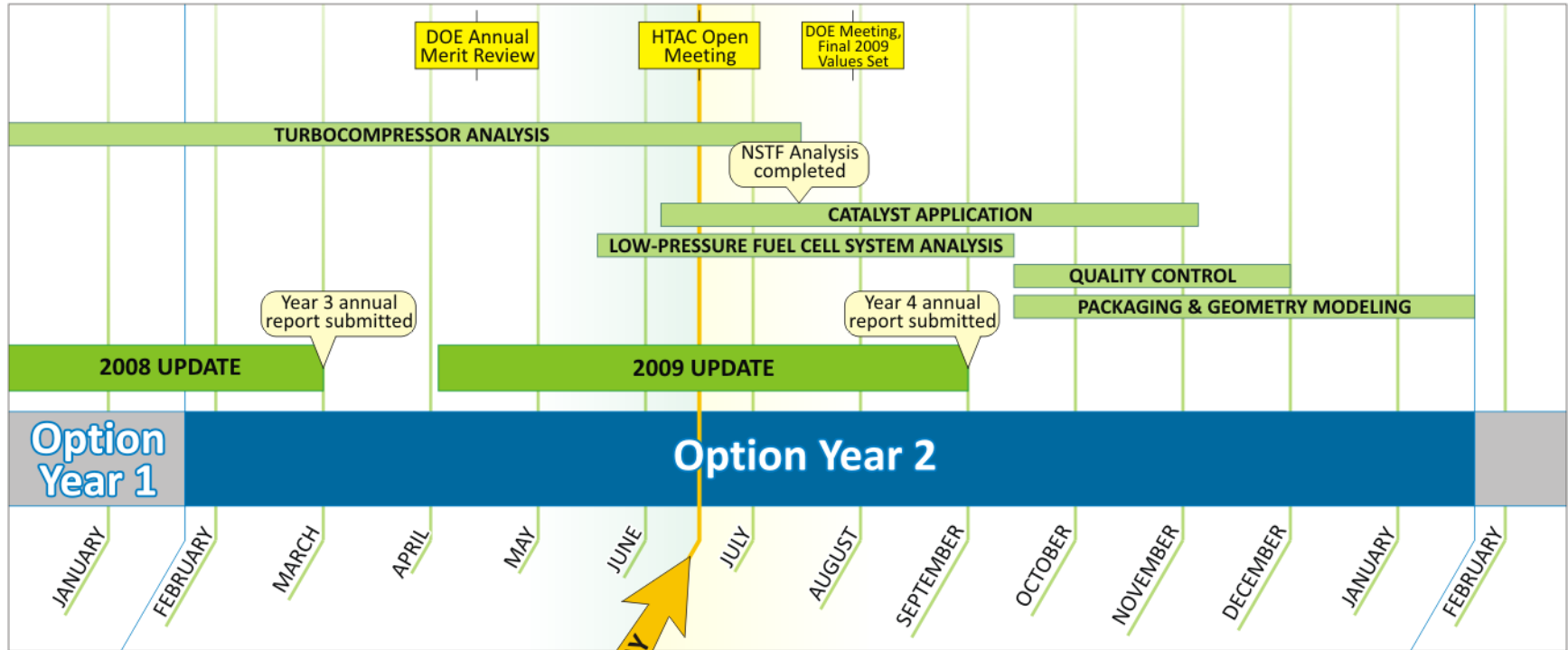

2009 Annual Update:

- New technology analysis
- Expanded sensitivity analysis
- Documentation & reporting

Additional Tasks:

- Low-Pressure Fuel Cell System Analysis
- Catalyst Application
 - Examine process options in detail (NSTF, decal, inking)
 - Build options into existing model, select best method

- Quality Control
 - Analyze impact of applying QC measures across all processes
- Packaging & Geometry Modeling
 - Refine BOP geometry
 - Ensure spatial feasibility of FC system in vehicle
- Turbocompressor Analysis
 - Continue work with Honeywell to examine existing CMEU designs
 - Develop detailed cost breakdown, identify new cost-saving pathways

End of Presentation

Thank you.

Additional Slides

The following slides are provided for further clarification

Application of Markup

- **DTI cost study applies markup as follows:**
 - **No fuel cell system OEM markup is applied**
 - OEM is entity that sells final FC System (i.e. Ballard, UTC, GM, etc.)
 - **We assume vertical integration for fuel cell stack**
 - Stack is manufactured and assembled in-house by OEM
 - Thus there is no markup on stack manufacture and assembly
 - **Exception to Rule:** Membrane fabricated by Tier 1 Supplier so there is manufacturing markup to that supplier
 - **BOP components are purchased from vendors**
 - Thus there is manufacturing and component assembly markup to that supplier
 - **Purchased materials & components contain supplier markup**
 - **No markup is associated with the final system assembly**

Purchased Materials & Components

Fuel Cell Stack

Flow Plates (Injection Molding)

- Polypropylene
- Conductive Filler (Vulcan XC-72)

Flow Plates (Stamping)

- Stainless Steel 316L Sheet

MEA

Membranes

- ePTFE Substrate
- Ionomer

Cost of membrane determined by DFMA analysis. Assumed to be purchased from supplier so Tier 1 markups are applied.

Catalyst Ink

- Carbon-Supported Platinum
- Chloroplatinic Acid
- Platinum
- Carbon Support (Vulcan XC-72)

CPA purchased from Tier 1 supplier. But Pt is supplied by OEM to avoid Tier 1 markup of the Pt. Analogous to precious metal purchases for catalytic converters.

Solvent

- Methanol
- DI Water
- Carbon Powder (Vulcan XC-72)

GDLs

Macroporous Layer

- Macroporous Substrate
- PTFE
- Solvent

Macroporous Substrate based on vendor quote with markup subtracted from quote to reflect OEM if made by OEM.

- Methanol
- DI Water

Microporous Layer

- Carbon Powder (Vulcan XC-72)
- PTFE
- Solvent

- Methanol
- DI Water

MEA Frame Gaskets

- Henkel Loctite LIM Hydrocarbon

End Gaskets

- Type A Resin

Endplates

- Thermoset Resin (LYTEX 9063)

Current Collectors

- Copper Sheet
- Copper Rod

Compression Bands

All materials and components listed in **red** are purchased from a tier 1 supplier, and thus include an **implicit manufacturer markup**

Balance of Plant

Mounting Frames

[All Sub-Components]

Air Loop

Air Compressor, Expander, Motor

[All Sub-Components]

[All Other Sub-Components]

Humidifier & Water Recovery Loop

Air Humidifier Assembly

[All Sub-Components]

[All Other Sub-Components]

Coolant Loop (High Temp Loop & Low Temp Loop)

[All Sub-Components]

Fuel Loop

[All Sub-Components]

System Controller/Sensors

[All Sub-Components]

Miscellaneous BOP

Wiring

[All Sub-Components]

Belly Pan

[All Sub-Components]

[All Other Sub-Components]

2008 Technology Schematic

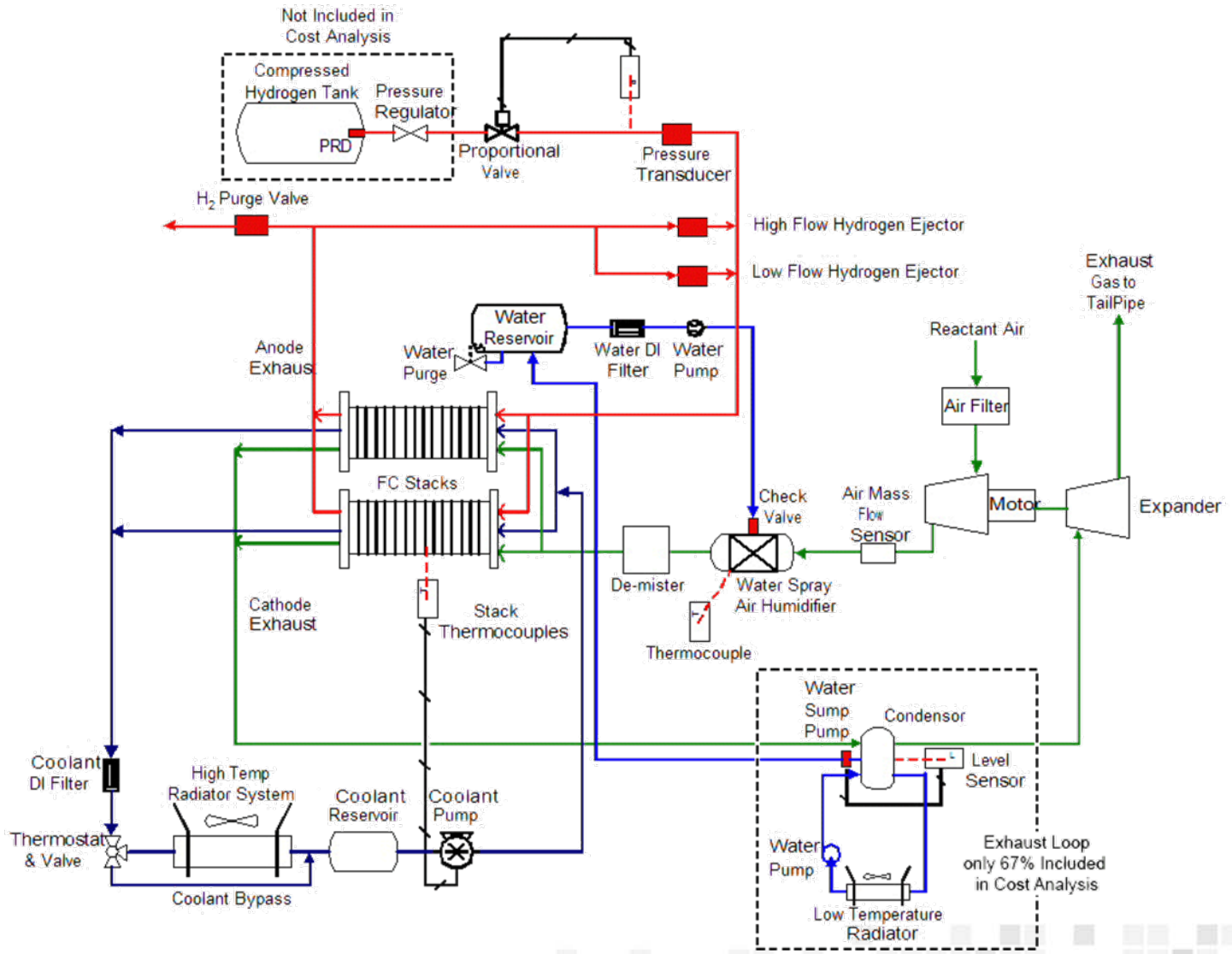

2010 Technology Schematic

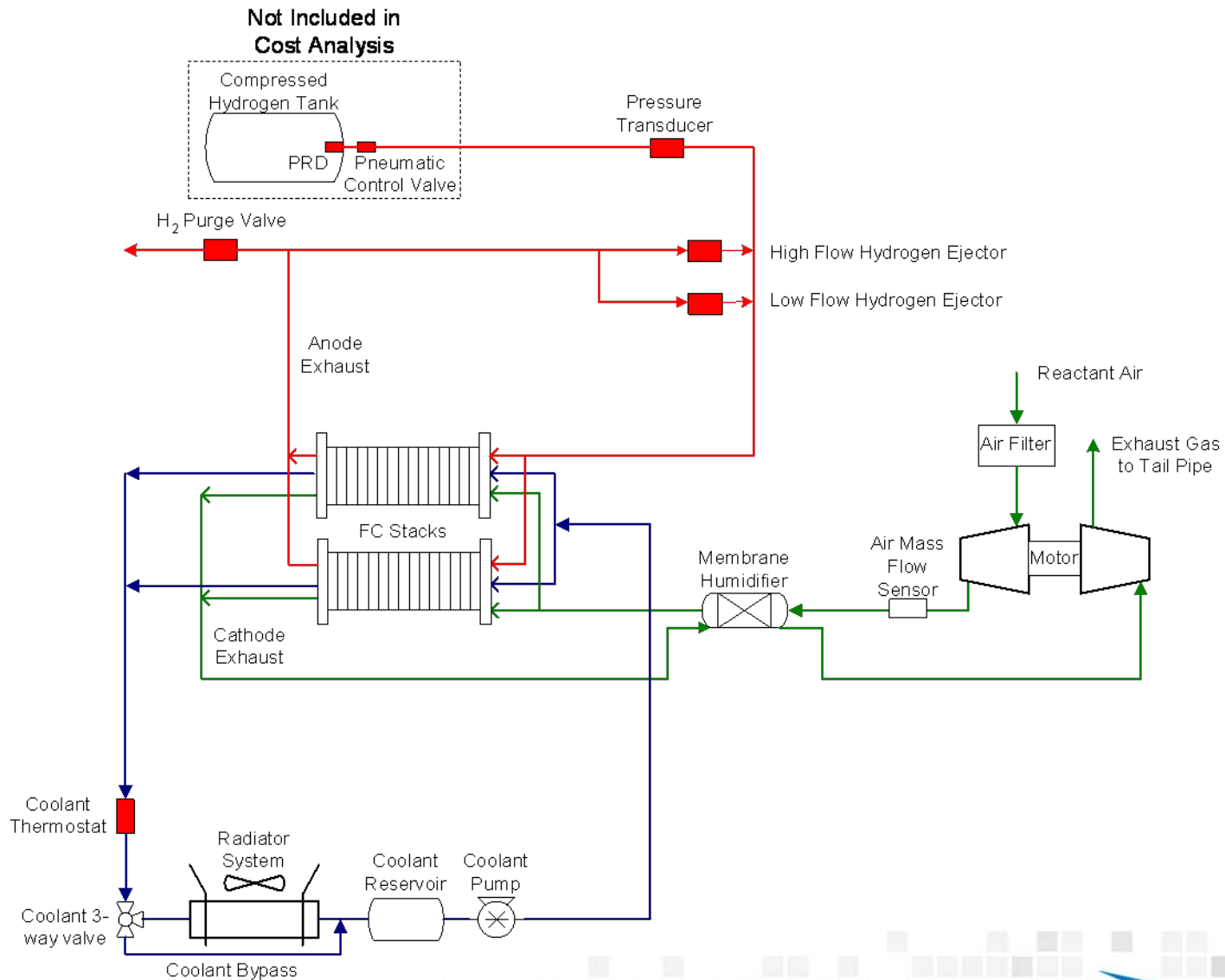

2015 Technology Schematic

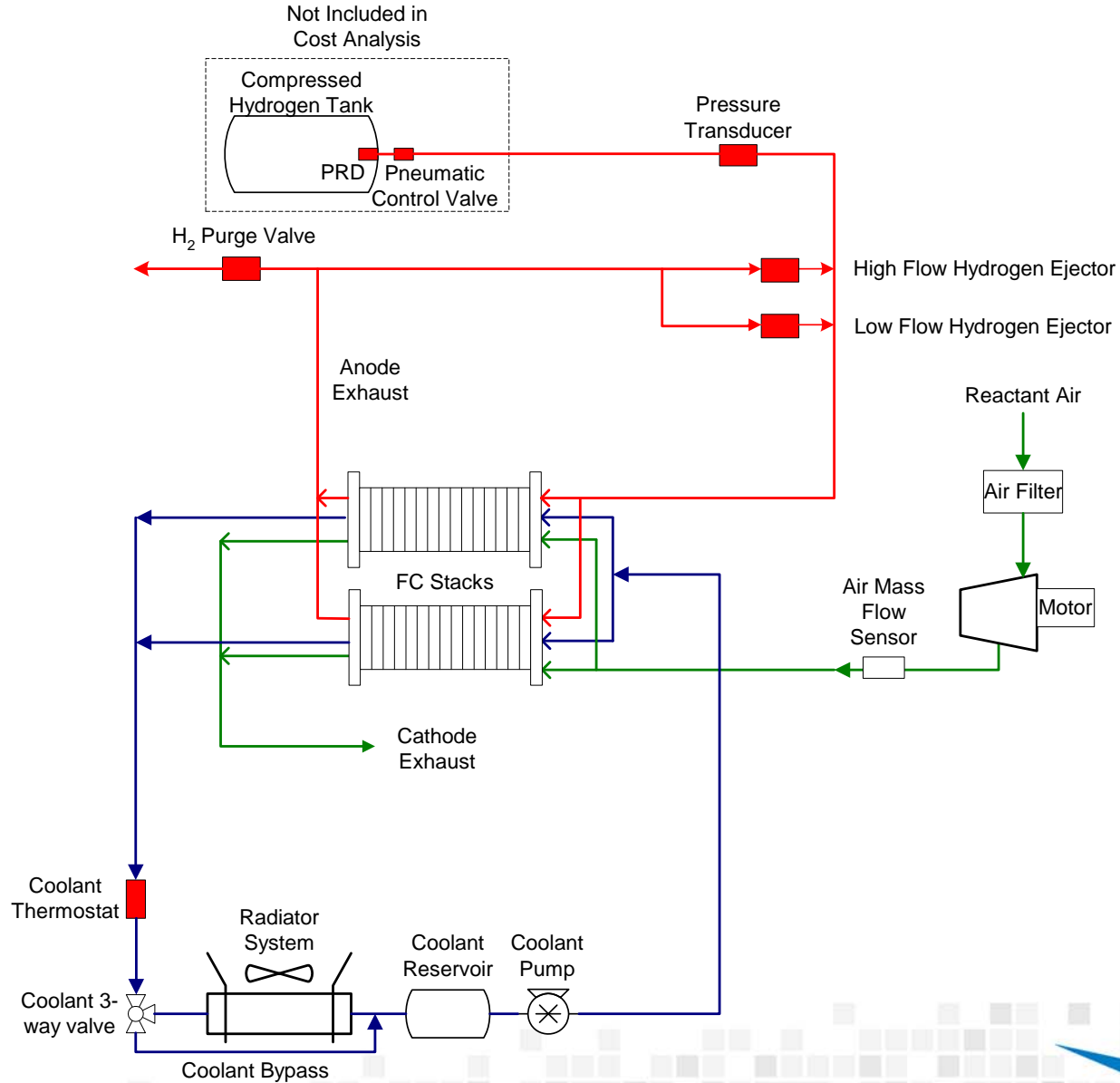

Bill of Materials: Stack (2008 Technology)

Annual Production Rate	1,000	30,000	80,000	130,000	500,000
System Net Electric Power (Output)	80	80	80	80	80
System Gross Electric Power (Output)	90.23	90.23	90.23	90.23	90.23
Bipolar Plates (Stamped)	\$898.77	\$249.99	\$253.83	\$250.56	\$249.09
MEAs					
Membranes	\$2,829.02	\$499.02	\$313.29	\$246.74	\$132.43
Catalyst Ink & Application	\$880.36	\$659.52	\$653.29	\$651.79	\$642.12
GDLs	\$1,090.28	\$706.44	\$438.50	\$343.06	\$160.90
M & E Hot Pressing	\$38.63	\$9.33	\$9.18	\$9.42	\$9.16
M & E Cutting & Slitting	\$30.20	\$3.59	\$3.01	\$2.88	\$2.83
MEA Frame/Gaskets	\$137.90	\$247.03	\$241.37	\$239.85	\$233.07
Coolant Gaskets (Laser Welding)	\$94.31	\$19.51	\$15.03	\$14.00	\$14.14
End Gaskets (Screen Printing)	\$75.69	\$2.63	\$1.05	\$0.69	\$0.31
End Plates	\$69.90	\$37.97	\$34.02	\$31.74	\$23.85
Current Collectors	\$13.89	\$7.84	\$6.79	\$6.35	\$5.89
Compression Bands	\$10.00	\$8.00	\$6.00	\$5.50	\$5.00
Stack Assembly	\$39.56	\$20.82	\$17.91	\$18.31	\$17.84
Stack Conditioning	\$27.50	\$10.93	\$10.42	\$10.45	\$10.39
Total Stack Cost	\$6,236.02	\$2,482.61	\$2,003.70	\$1,831.35	\$1,507.03
Total Cost for All Stacks	\$12,472.04	\$4,965.23	\$4,007.39	\$3,662.69	\$3,014.06
Total Stack Cost (\$/kW_{net})	\$155.90	\$62.07	\$50.09	\$45.78	\$37.68
Total Stack Cost (\$/kW_{gross})	\$138.23	\$55.03	\$44.41	\$40.59	\$33.40

- 4.4 to 1 cost reduction between low and high manufacturing rates

Bill of Materials: Stack (2010 Technology)

Annual Production Rate	1,000	30,000	80,000	130,000	500,000
System Net Electric Power (Output)	80	80	80	80	80
System Gross Electric Power (Output)	86.71	86.71	86.71	86.71	86.71
Bipolar Plates (Stamped)	\$842.68	\$197.28	\$199.94	\$196.14	\$195.06
MEAs					
Membranes	\$2,304.36	\$415.97	\$257.01	\$200.55	\$104.31
Catalyst Ink & Application	\$760.44	\$547.76	\$541.92	\$539.16	\$531.73
GDLs	\$958.30	\$487.28	\$306.01	\$239.59	\$114.48
M & E Hot Pressing	\$38.01	\$7.52	\$7.67	\$7.71	\$7.55
M & E Cutting & Slitting	\$30.18	\$3.57	\$3.00	\$2.86	\$2.76
MEA Frame/Gaskets	\$241.26	\$166.11	\$162.09	\$160.96	\$156.32
Coolant Gaskets (Laser Welding)	\$93.59	\$13.30	\$12.56	\$12.38	\$12.11
End Gaskets (Screen Printing)	\$75.68	\$2.62	\$1.04	\$0.68	\$0.30
End Plates	\$53.09	\$25.63	\$23.62	\$21.55	\$16.49
Current Collectors	\$10.84	\$5.82	\$5.01	\$4.68	\$4.34
Compression Bands	\$10.00	\$8.00	\$6.00	\$5.50	\$5.00
Stack Assembly	\$39.56	\$20.82	\$17.91	\$18.31	\$17.84
Stack Conditioning	\$26.15	\$8.88	\$8.54	\$8.46	\$8.33
Total Stack Cost	\$5,484.13	\$1,910.58	\$1,552.34	\$1,418.55	\$1,176.63
Total Cost for All Stacks	\$10,968.26	\$3,821.15	\$3,104.68	\$2,837.09	\$2,353.26
Total Stack Cost (\$/kW_{net})	\$137.10	\$47.76	\$38.81	\$35.46	\$29.42
Total Stack Cost (\$/kW_{gross})	\$126.49	\$44.07	\$35.80	\$32.72	\$27.14

- 4.7 to 1 cost reduction between low and high manufacturing rates

Bill of Materials: Stack (2015 Technology)

Annual Production Rate	1,000	30,000	80,000	130,000	500,000
System Net Electric Power (Output)	80	80	80	80	80
System Gross Electric Power (Output)	87.06	87.06	87.06	87.06	87.06
Bipolar Plates (Stamped)	\$843.17	\$197.75	\$200.40	\$196.60	\$195.52
MEAs					
Membranes	\$2,310.61	\$417.98	\$258.26	\$201.53	\$104.83
Catalyst Ink & Application	\$567.75	\$368.67	\$364.24	\$361.84	\$356.89
GDLs	\$961.34	\$489.32	\$307.26	\$240.54	\$114.88
M & E Hot Pressing	\$38.01	\$7.53	\$7.67	\$7.71	\$7.55
M & E Cutting & Slitting	\$30.18	\$3.57	\$3.00	\$2.86	\$2.76
MEA Frame/Gaskets	\$242.10	\$166.81	\$162.78	\$161.64	\$156.98
Coolant Gaskets (Laser Welding)	\$93.60	\$13.30	\$12.56	\$12.39	\$12.11
End Gaskets (Screen Printing)	\$75.68	\$2.62	\$1.04	\$0.68	\$0.30
End Plates	\$53.24	\$25.73	\$23.72	\$21.64	\$16.56
Current Collectors	\$10.87	\$5.84	\$5.03	\$4.70	\$4.35
Compression Bands	\$10.00	\$8.00	\$6.00	\$5.50	\$5.00
Stack Assembly	\$39.56	\$20.82	\$17.91	\$18.31	\$17.84
Stack Conditioning	\$24.79	\$6.84	\$6.40	\$6.30	\$6.27
Total Stack Cost	\$5,300.90	\$1,734.78	\$1,376.28	\$1,242.25	\$1,001.83
Total Cost for All Stacks	\$10,601.79	\$3,469.55	\$2,752.55	\$2,484.49	\$2,003.67
Total Stack Cost (\$/kW_{net})	\$132.52	\$43.37	\$34.41	\$31.06	\$25.05
Total Stack Cost (\$/kW_{gross})	\$121.78	\$39.85	\$31.62	\$28.54	\$23.02

- 5.3 to 1 cost reduction between low and high manufacturing rates

Bill of Materials: Balance of Plant (2008 Technology)

Annual Production Rate	1,000	30,000	80,000	130,000	500,000
System Net Electric Power (Output)	80	80	80	80	80
System Gross Electric Power (Output)	90.23	90.23	90.23	90.23	90.23
Mounting Frames	\$100.00	\$43.00	\$33.00	\$30.00	\$30.00
Air Loop	\$2,616.69	\$1,364.16	\$1,063.94	\$954.11	\$803.28
Humidifier & Water Recovery Loop	\$535.13	\$379.81	\$315.54	\$300.75	\$273.77
Coolant Loop (High Temperature)	\$528.75	\$448.00	\$384.25	\$363.10	\$331.80
Exhaust Loop (Low Temperature)	\$169.18	\$147.40	\$130.32	\$123.28	\$113.90
Fuel Loop	\$927.50	\$747.00	\$566.50	\$528.40	\$457.20
System Controller/Sensors	\$300.00	\$245.00	\$230.00	\$222.00	\$200.00
Hydrogen Sensors	\$1,700.00	\$876.00	\$640.00	\$522.00	\$200.00
Miscellaneous	\$879.79	\$671.68	\$549.73	\$523.59	\$469.44
Total BOP Cost	\$7,757.03	\$4,922.05	\$3,913.28	\$3,567.24	\$2,879.39
Total BOP Cost (\$/kW_{net})	\$96.96	\$61.53	\$48.92	\$44.59	\$35.99
Total BOP Cost (\$/kW_{gross})	\$85.97	\$54.55	\$43.37	\$39.54	\$31.91

- 2.7 to 1 cost reduction between low and high manufacturing rates

Bill of Materials: Balance of Plant (2010 Technology)

Annual Production Rate	1,000	30,000	80,000	130,000	500,000
System Net Electric Power (Output)	80	80	80	80	80
System Gross Electric Power (Output)	86.71	86.71	86.71	86.71	86.71
Mounting Frames	\$100.00	\$43.00	\$33.00	\$30.00	\$30.00
Air Loop	\$1,887.03	\$1,327.82	\$1,003.72	\$891.74	\$754.33
Humidifier & Water Recovery Loop	\$900.00	\$600.00	\$425.00	\$350.00	\$250.00
Coolant Loop (High Temperature)	\$498.24	\$420.54	\$358.32	\$338.69	\$308.92
Exhaust Loop (Low Temperature)	\$0.00	\$0.00	\$0.00	\$0.00	\$0.00
Fuel Loop	\$927.50	\$747.00	\$566.50	\$528.40	\$457.20
System Controller/Sensors	\$300.00	\$245.00	\$230.00	\$222.00	\$200.00
Hydrogen Sensors	\$750.00	\$367.00	\$256.00	\$201.00	\$50.00
Miscellaneous	\$827.61	\$626.81	\$505.90	\$480.29	\$427.70
Total BOP Cost	\$6,190.38	\$4,377.17	\$3,378.45	\$3,042.12	\$2,478.14
Total BOP Cost (\$/kW_{net})	\$77.38	\$54.71	\$42.23	\$38.03	\$30.98
Total BOP Cost (\$/kW_{gross})	\$71.39	\$50.48	\$38.96	\$35.08	\$28.58

- 2.5 to 1 cost reduction between low and high manufacturing rates

Bill of Materials: Balance of Plant (2015 Technology)

Annual Production Rate	1,000	30,000	80,000	130,000	500,000
System Net Electric Power (Output)	80	80	80	80	80
System Gross Electric Power (Output)	87.06	87.06	87.06	87.06	87.06
Mounting Frames	\$100.00	\$43.00	\$33.00	\$30.00	\$30.00
Air Loop	\$1,378.48	\$969.57	\$728.45	\$651.05	\$553.20
Humidifier & Water Recovery Loop	\$0.00	\$0.00	\$0.00	\$0.00	\$0.00
Coolant Loop (High Temperature)	\$453.75	\$380.50	\$320.50	\$303.10	\$275.55
Exhaust Loop (Low Temperature)	\$0.00	\$0.00	\$0.00	\$0.00	\$0.00
Fuel Loop	\$927.50	\$747.00	\$566.50	\$528.40	\$457.20
System Controller/Sensors	\$300.00	\$245.00	\$230.00	\$222.00	\$200.00
Hydrogen Sensors	\$0.00	\$0.00	\$0.00	\$0.00	\$0.00
Miscellaneous	\$812.72	\$614.00	\$493.40	\$467.93	\$415.78
Total BOP Cost	\$3,972.45	\$2,999.07	\$2,371.84	\$2,202.48	\$1,931.73
Total BOP Cost (\$/kW_{net})	\$49.66	\$37.49	\$29.65	\$27.53	\$24.15
Total BOP Cost (\$/kW_{gross})	\$45.63	\$34.45	\$27.25	\$25.30	\$22.19

- 2 to 1 cost reduction between low and high manufacturing rates

Bill of Materials: System (2008 Technology)

Annual Production Rate	1,000	30,000	80,000	130,000	500,000
System Net Electric Power (Output)	80	80	80	80	80
System Gross Electric Power (Output)	90.23	90.23	90.23	90.23	90.23
Fuel Cell Stacks	\$12,472.04	\$4,965.23	\$4,007.39	\$3,662.69	\$3,014.06
Balance of Plant	\$7,757.03	\$4,922.05	\$3,913.28	\$3,567.24	\$2,879.39
System Assembly & Testing	\$158.84	\$114.18	\$112.24	\$112.39	\$112.01
Total System Cost	\$20,387.92	\$10,001.46	\$8,032.91	\$7,342.32	\$6,005.46
Total System Cost (\$/kW_{net})	\$254.85	\$125.02	\$100.41	\$91.78	\$75.07
Total System Cost (\$/kW_{gross})	\$225.96	\$110.85	\$89.03	\$81.38	\$66.56

- 3.4 to 1 cost reduction between low and high manufacturing rates

Bill of Materials: System (2010 Technology)

Annual Production Rate	1,000	30,000	80,000	130,000	500,000
System Net Electric Power (Output)	80	80	80	80	80
System Gross Electric Power (Output)	86.71	86.71	86.71	86.71	86.71
Fuel Cell Stacks	\$10,968.26	\$3,821.15	\$3,104.68	\$2,837.09	\$2,353.26
Balance of Plant	\$6,190.38	\$4,377.17	\$3,378.45	\$3,042.12	\$2,478.14
System Assembly & Testing	\$158.62	\$113.99	\$112.06	\$112.21	\$111.83
Total System Cost	\$17,317.25	\$8,312.32	\$6,595.19	\$5,991.42	\$4,943.23
Total System Cost (\$/kW_{net})	\$216.47	\$103.90	\$82.44	\$74.89	\$61.79
Total System Cost (\$/kW_{gross})	\$199.71	\$95.86	\$76.06	\$69.10	\$57.01

- 3.5 to 1 cost reduction between low and high manufacturing rates

Bill of Materials: System (2015 Technology)

Annual Production Rate	1,000	30,000	80,000	130,000	500,000
System Net Electric Power (Output)	80	80	80	80	80
System Gross Electric Power (Output)	87.06	87.06	87.06	87.06	87.06
Fuel Cell Stacks	\$10,601.79	\$3,469.55	\$2,752.55	\$2,484.49	\$2,003.67
Balance of Plant	\$3,972.45	\$2,999.07	\$2,371.84	\$2,202.48	\$1,931.73
System Assembly & Testing	\$158.62	\$113.99	\$112.06	\$112.21	\$111.83
Total System Cost	\$14,732.86	\$6,582.62	\$5,236.45	\$4,799.18	\$4,047.23
Total System Cost (\$/kW_{net})	\$184.16	\$82.28	\$65.46	\$59.99	\$50.59
Total System Cost (\$/kW_{gross})	\$169.24	\$75.61	\$60.15	\$55.13	\$46.49

- 3.6 to 1 cost reduction between low and high manufacturing rates