

Membrane Applications for Nuclear Hydrogen Production Processes

*Brian L. Bischoff, Dane F. Wilson, Lawrence E. Powell,
and K. Dale Adcock*

Oak Ridge National Laboratory*

P.O. Box 4699, Oak Ridge, TN 37831

Tel: 865-241-3172, Fax: 865-576-3502, Email: bischoffbl@ornl.gov

Presented at

**DOE Hydrogen Program Annual Review
Crystal City, VA**

**May 16, 2006
Project #PDP23**

*This research was sponsored by the Laboratory Directed Research and Development Program of Oak Ridge National Laboratory, managed by UT-Battelle, LLC, for the U.S. Department of Energy under Contract No. DE-AC05-00OR22725. Accordingly, the U.S. Government retains a nonexclusive, royalty-free license to publish or reproduce the published form of this contribution, or allow others to do so, for U.S. Government purposes.

This presentation does not contain any proprietary or confidential information

Project Overview

Budget (\$K)

	Sulfur Cycles	High Temperature Electrolysis
FY2005	170	60
FY2006	380	100

Partners and Collaborators

- General Atomics
- Idaho Falls National Laboratory

Objectives

Sulfur Cycles

To assess the potential for high temperature inorganic membranes for use in the decomposition of sulfuric acid.

- **Evaluate stability of membrane materials in the corrosive SO_2/SO_3 environment.**
- **Fabricate membranes from compatible materials and initiate testing of membrane separation efficiency.**

HTE

To analyze the applicability of high temperature inorganic membranes, developed at ORNL, for the separation of hydrogen from steam at the outlet conditions of the solid oxide electrolyzer cells.

Approach

Sulfur Cycles

The primary tasks are:

- 1) - Identification of candidate high temperature membrane materials
- 2) - Candidate membrane and support tube fabrication studies
- 3) - Membrane and support tube materials compatibility testing
- 4) - Conduct membrane separations tests

These initial studies will provide basis and initial separations for prioritizing further investigations on membrane materials for the high temperature step in the Sulfur cycles.

High Temperature Electrolysis

- 1) Test ORNL inorganic membranes for the separation of hydrogen from steam at electrolyzer conditions for extended period of time.

ORNL's Inorganic Membrane Fabrication Process is Quite Versatile

- Pore diameters of 0.5 nm – 20,000 nm; for H₂, pore diameters of <1 nm are preferred
- Tubular support structure and layer made of variety of metals and ceramics
- Excellent mechanical, thermal, and chemical stability
- Membrane layer(s) applied to inside of support tube
- Membrane layer thickness of 2 μm or less yields high gas flows at low pressure drop; small pores result in high selectivity
- Proven scalability



A Thin Separation Layer Allows High Flow of Gases Through Small Pore Membranes

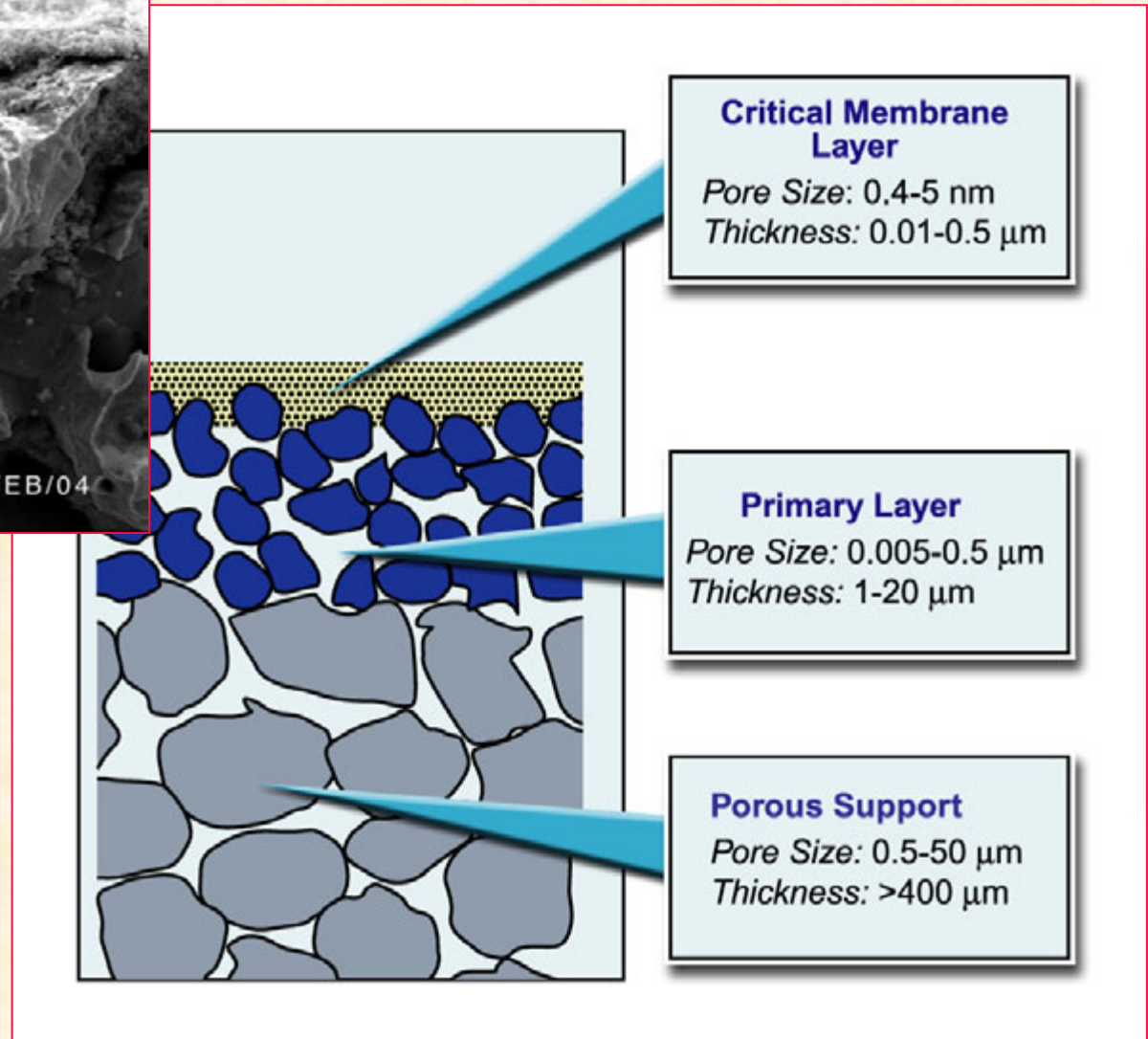
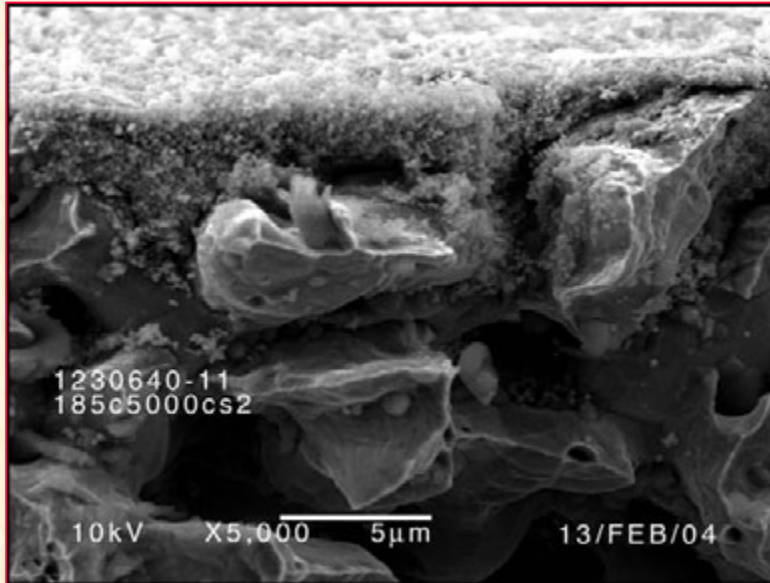

In Distinct Contrast To Palladium Or Ion Transport Membranes, These Are Porous

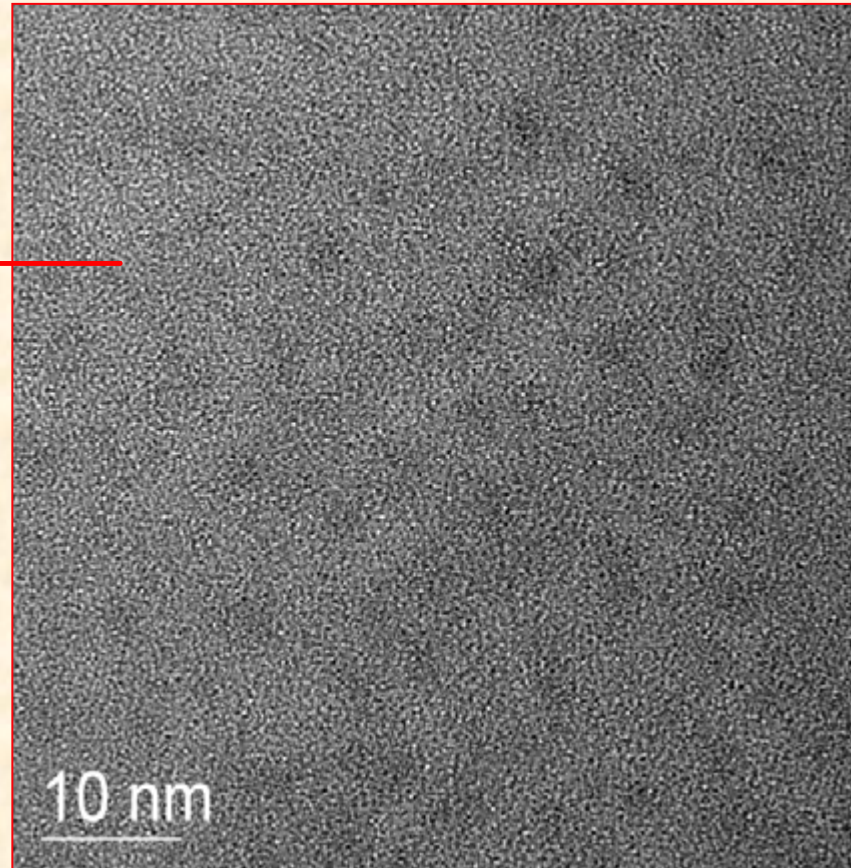
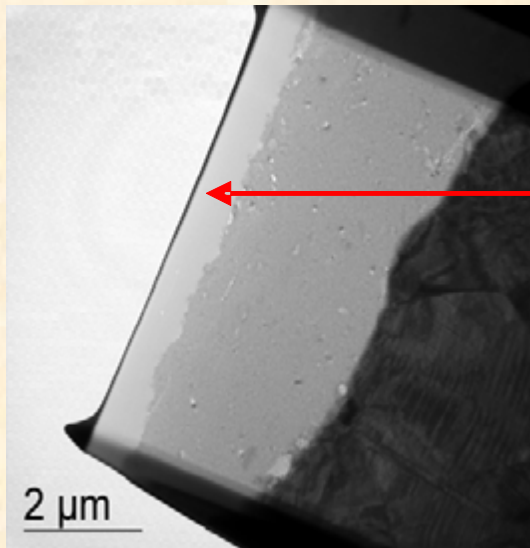

Membranes are descriptively nanoporous with pore sizes < 2 nm, but IUPAC nomenclature is 'microporous' (I didn't make the rules)

Thermochemical Cycles can be Used to Produce Hydrogen from Water

- **Water + Heat \Rightarrow Hydrogen + Oxygen**
- **Sulfur-based thermochemical cycles are the leading options**
- **Sulfur cycles require very high temperatures (850°C)**
 - **At the limits of reactor technology**
 - **At the limits of practical materials**
 - **Large incentives exist to reduce temperatures**
- **A method to lower peak temperatures by 100 to 200°C is being developed using inorganic membranes**

Sulfur Family of Thermochemical Cycles

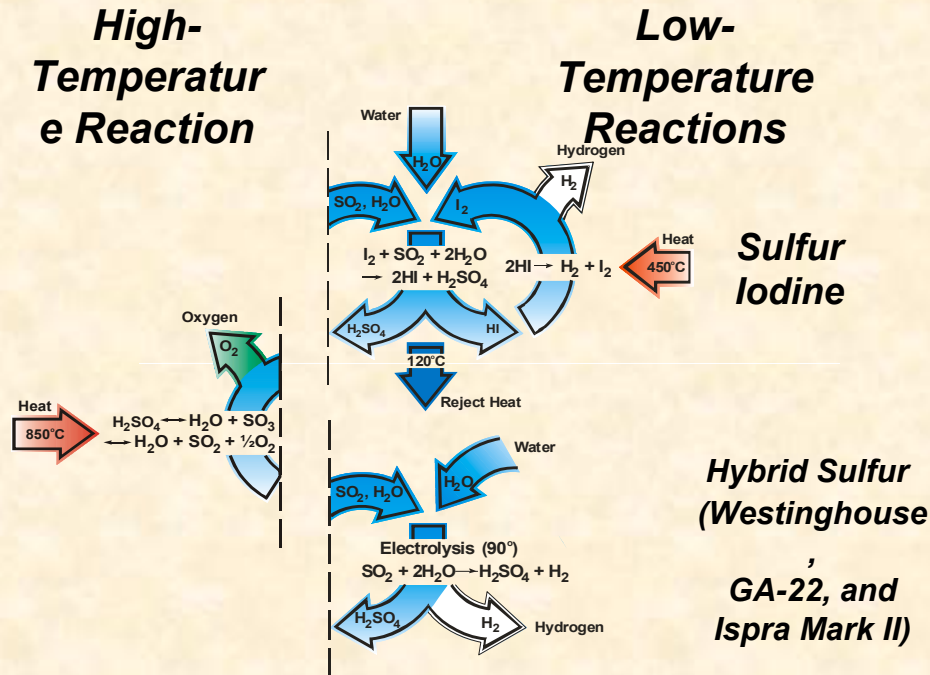

- Shift the equilibrium of the high-temperature reaction to completion by removing the reaction products using inorganic membrane

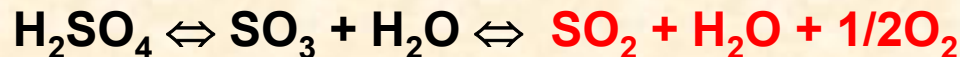

- Membrane separation of O_2 , H_2O , and SO_2 from SO_3 drives reaction to the right, thus allowing high conversion at lower reaction temperatures
- Potential exists to reduce peak temperature to between 650 and 750°C

Experimental Test Facility

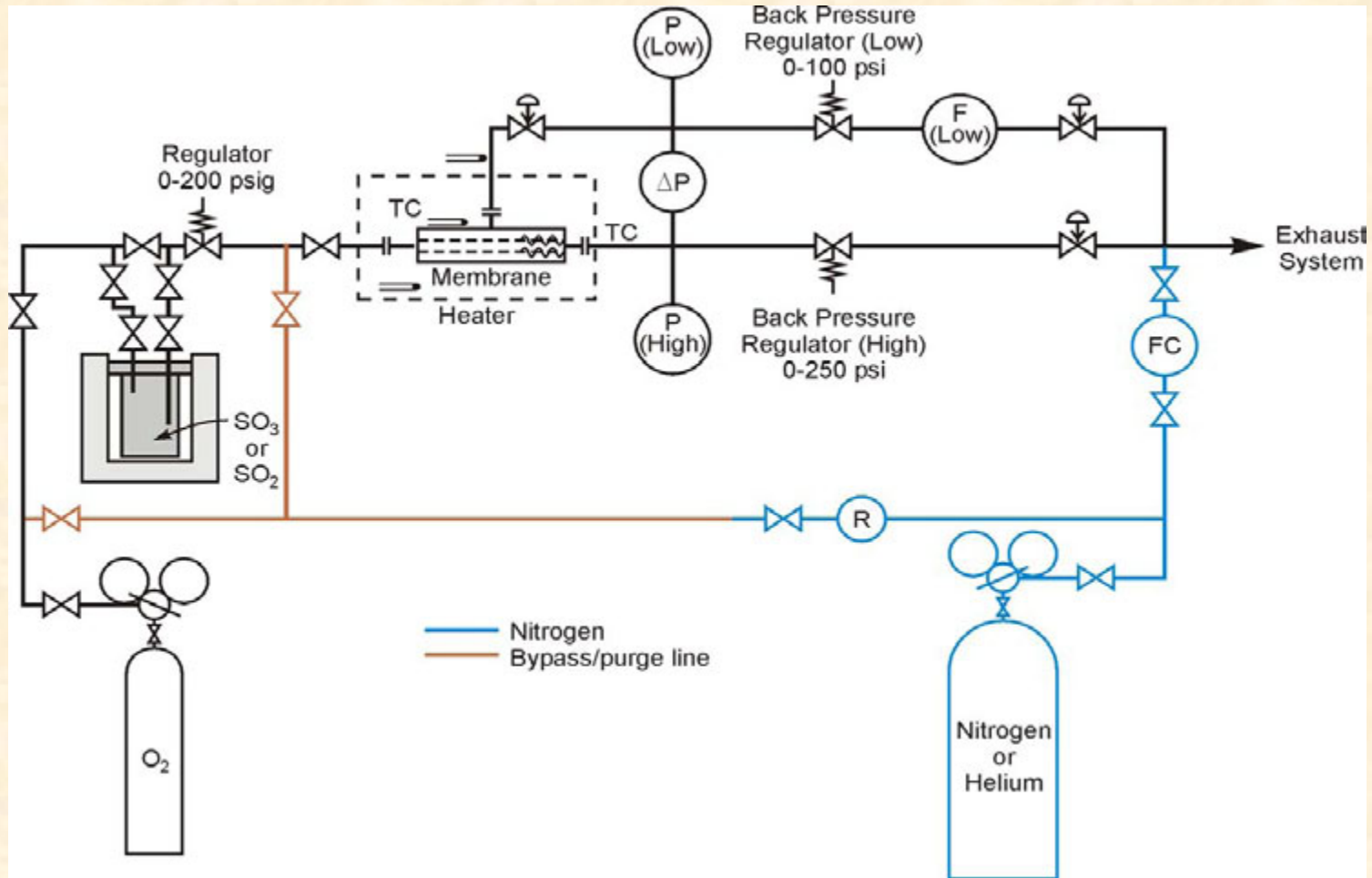

1st Generation Membrane Tests: SO₂/SO₃ and O₂/SO₃ Separation Factors Exceed 2 in Low-Temperature Tests

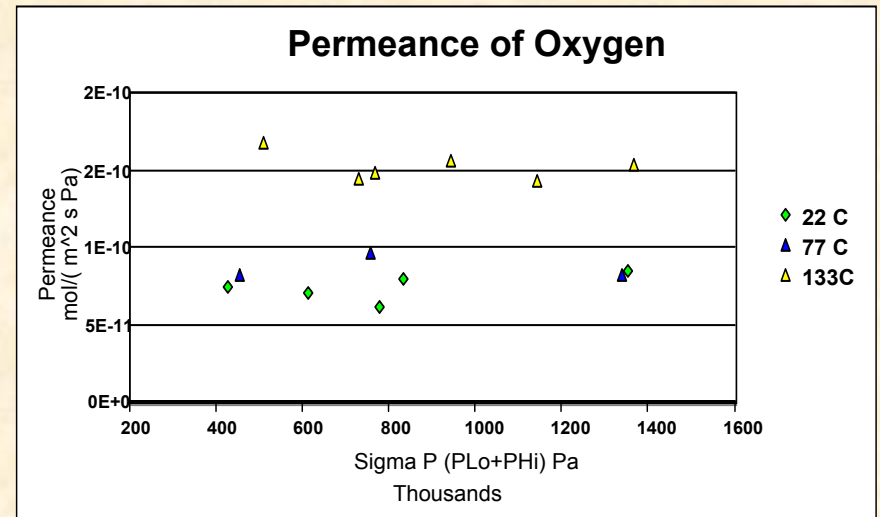
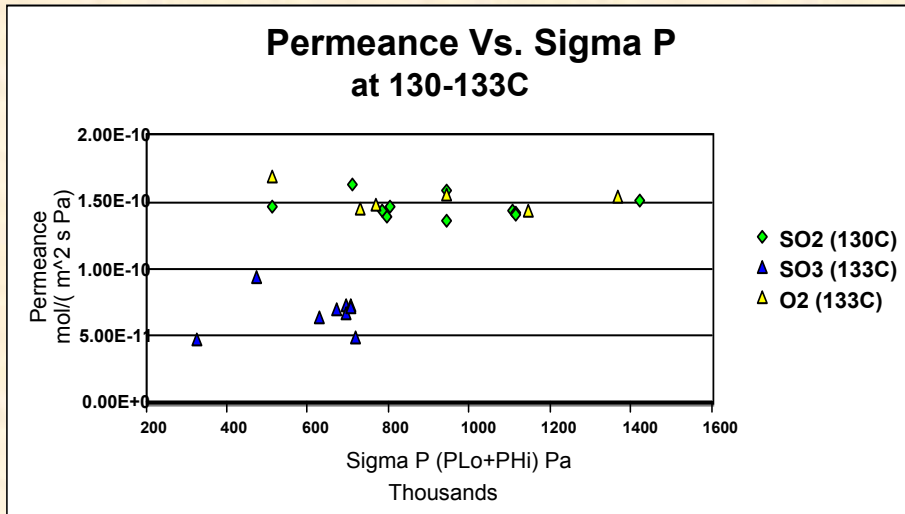

Oxygen Data Shows Flow Through Membrane Increases with Temperature: Indicative of Desirable Thermally-Activated Diffusion. This Thermally-Activated Diffusion will Result in Higher Permeance and Higher Separation Factors at Higher Temperatures

Support Materials Selection

The following materials have been identified as potential candidates for support tube fabrication

- 1) Hastelloy B2 or B3
- 2) Hastelloy C22
- 3) Hastelloy G
- 4) Monel
- 5) MA20Nb-3
- 6) MA825
- 7) Nickel-Copper alloy

While these materials may contain elements that form low melting sulfur compounds, they will allow for the determination of reaction products and morphologies that guide the selection and development of materials that can survive in the environment

Powders in the desired size and morphology of the following have been located and procured.

- 1) Hastelloy C22
- 2) Monel

Porous coupon-sized samples have been fabricated and sintered.

Plan for the Remaining FY

- **Characterize coupon samples for flow properties and mechanical properties (elastic modulus and in-plane biaxial strength). Edgar Lara-Curzio (Material Science and Technology Division) has developed these techniques which can be applied to our coupon samples.**
- **Expose samples to SO_3 and SO_2 at high temperatures of 500-900 °C.**
- **Characterize exposed samples to determine effect on support materials**
- **Design and fabricate improved membrane flow test system**

Initial Support Materials

The following materials have been selected as initial candidates for support tube fabrication studies. Although these materials may not survive the exposure tests, they will allow for the determination of reaction products and morphologies that guide the selection and development of materials that can survive in the environment.

- **Alloy C-22 (typical composition in weight %):** carbon 0.015 max.; chromium 20-22.5; cobalt 2.5 min.; iron 2-6; manganese 0.5 max.; molybdenum 12.5-14.5; nickel balance; phosphorus 0.02 max.; silicon 0.08 max.; sulfur 0.02 max.; tungsten 2.5-3.5; and vanadium 0.35 min.;
- **Monel:** nickel 63 min.; carbon 0.3 max.; manganese 2.0 max., iron 2.5 max.; sulfur 0.025-0.060; silicon 0.5 max.; copper 28-34; and
- **Type 430 SS:** chromium 16-18; nickel <0.75; carbon 0.12; silicon 1.0; phosphorus 0.04; and sulfur 0.030.

Coupon Samples Are Being Evaluated Initially

- Characterize coupon samples for flow properties and mechanical properties (elastic modulus and in-plane biaxial strength).
- Expose samples to SO_3 and SO_2 at high temperatures of 500-900 °C.
- Characterize exposed samples to determine effect on support materials

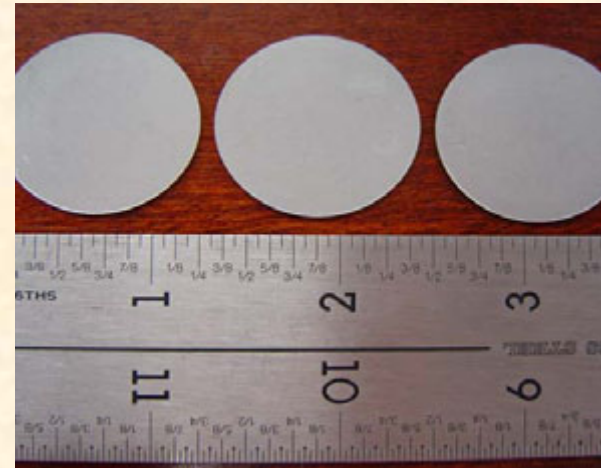
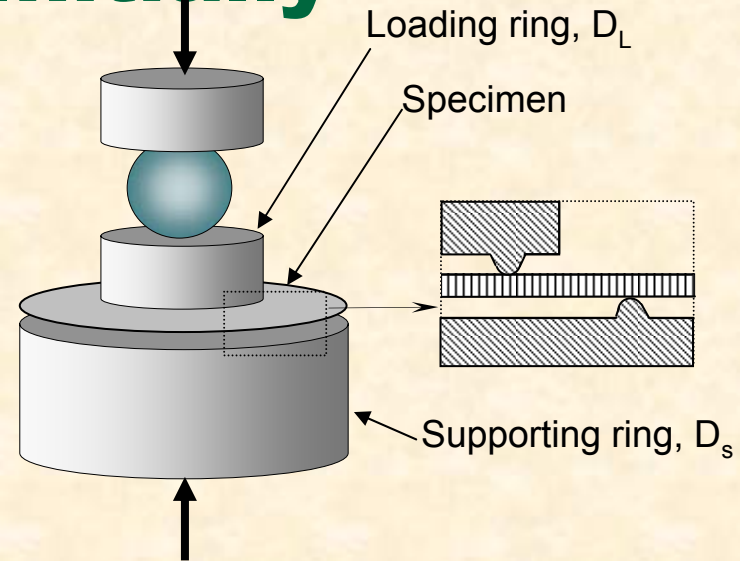

Exposure Test System Completed



Appropriate ratios of sulfide dioxide and an argon/oxygen is fed into the test reactor consisting of concentric quartz tubes, to establish the desired ratios of SO_2 to SO_3 . The gases are heated to temperature by feeding them down the annulus between the concentric tubes prior to flowing up the central tube pass the specimens.

C-22 Was Tested to Determine What Elements are Most Reactive In the Environment

❖ At 500°C for 168 h in 3:1
SO₂:O₂

- 21.85 mg/cm²
 - Very fast rate
- Elemental cross-sectional analyses are on-going
 - Significant attack across cross-section of specimens

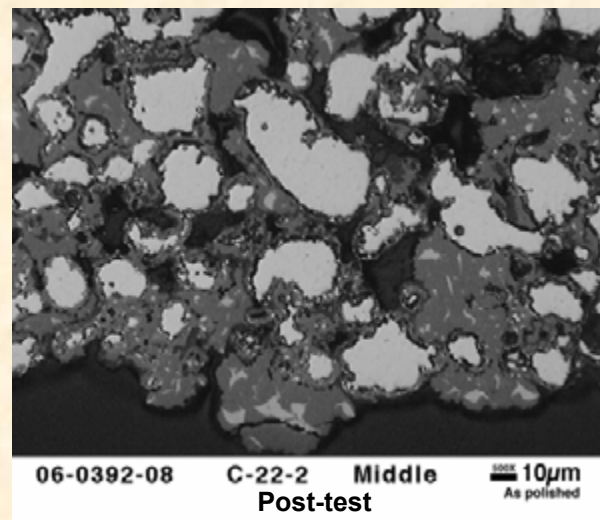
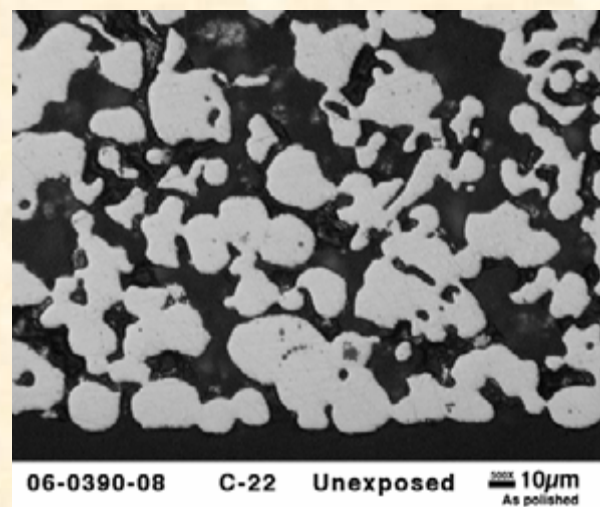
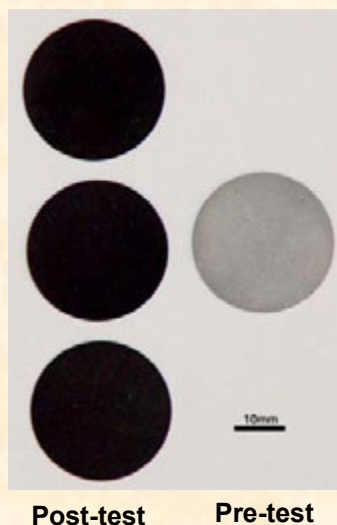

Significant Oxygen and Sulfur Found in C-22 Reaction Product

Sulfur rich nodules

Oxygen rich

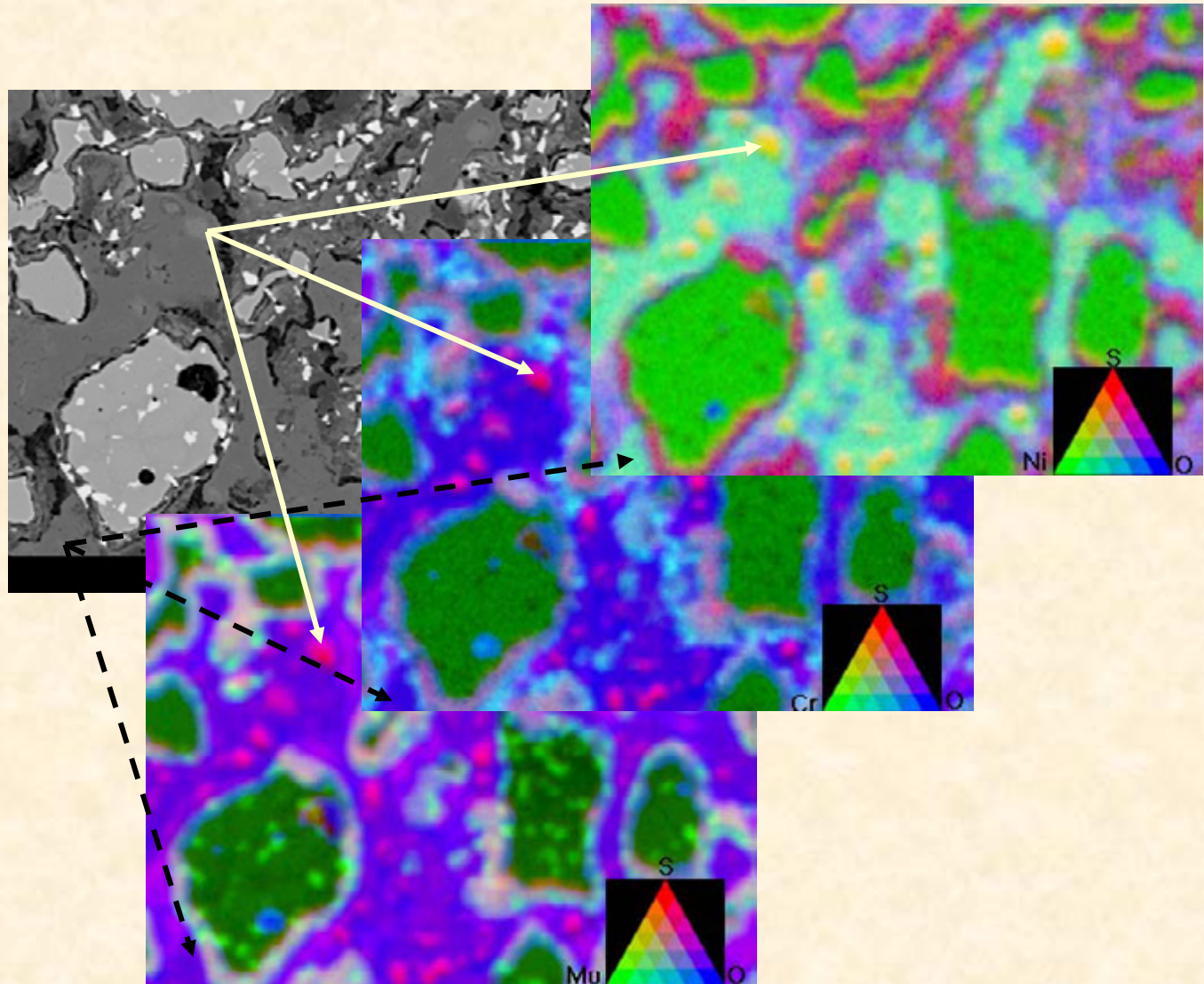

SI Conclusions to Date

- Inorganic membranes are compatible with process chemicals up to 130 °C
- Initial experiments show nanopore diffusion with permeance increasing with temperature—the desired behavior for a sulfur thermochemical membrane
- Initial experiments with first-generation membranes show low-temperature separation of O₂ and SO₂ from SO₃
 - Separation factor for O₂/SO₃: 2.3
 - Separation factor for SO₂/SO₃: 2.2
- Preliminary work is highly encouraging and suggests that a practical separations membrane can be developed

High Temperature Electrolysis

Outlet of electrolyzer

H₂ - 75-85 % with the balance steam at 600-900 °C and 1-5 MPa

Target is for membrane to produce hydrogen at 90-95% purity

Reject stream will be fed back into electrolyzer

Hydrogen is larger than Water molecule so separation cannot be accomplished by molecular sieving. Separation by Knudsen diffusion is

$$SF = \left(\frac{M_{Water}}{M_{Hydrogen}} \right)^{1/2} = 3$$

Operating Conditions for Electrolyzer Membrane System

Operating temperature in electrolyzer	750-900 °C
Pressure exiting electrolyzer	1-5 MPa
Temperature of stream entering membrane	600-800 °C
Concentration of hydrogen exiting the electrolyzer	75-85%
Concentration of hydrogen permeating through membrane	95-99%
Raffinate (reject) stream hydrogen concentration	20-50%

Reject stream is sent back to feed of electrolyzer at temperature

High Temperature Electrolysis

Measured Separation Factor (SF)

$$\text{SF} = (\text{Conc. H}_2 \text{ out}/\text{Conc. H}_2 \text{ in})/(\text{Conc. H}_2\text{O out}/\text{Conc. H}_2\text{O in})$$

For 75% H₂ One Stage Conc. H₂ = 90%

Two Stages Conc. H₂ = 96.4%

Three Stages Conc. H₂ = 98.8%

For 85% H₂ One Stage Conc. H₂ = 94.4%

Two Stages Conc. H₂ = 98.1%

Three Stages Conc. H₂ = 99.4%

Metal Supported 70 Å Ceramic Membrane Achieves Knudsen Separation

1514-X-43a
Permeance vs Temp
Mar 2005

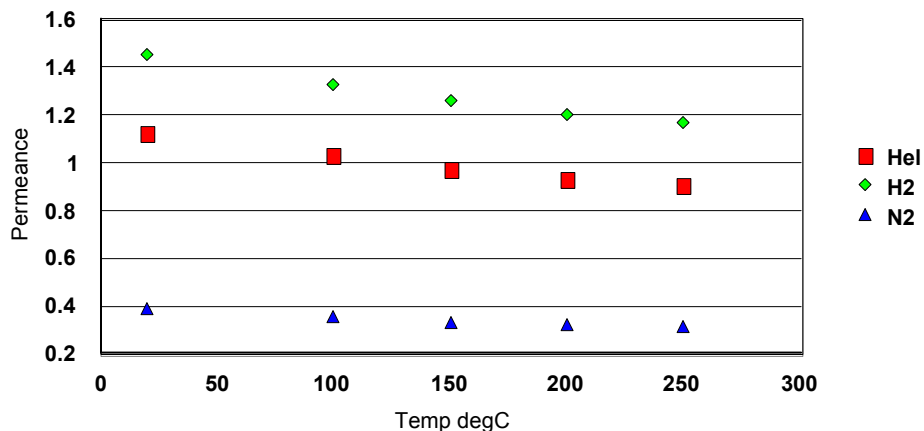

1514-X-43
Separation Factor
Mar 2005

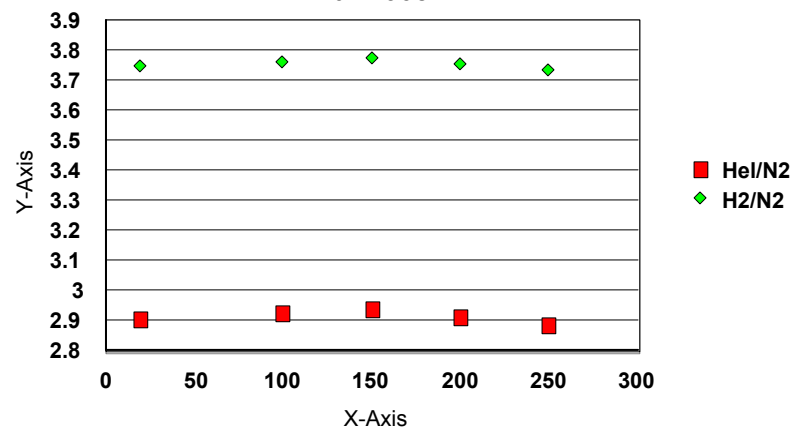

Theoretical Separation Factors

H₂/N₂ 3.74

He/N₂ 2.65

Early Mixed Gas Separation Results

Temperature °C	% Hydrogen in Feed	% Hydrogen in Permeate	Separation Factor
200	37.0	52.1	1.85
300	59.2	72.1	1.79
400	67.3	79.2	1.85

New Test System Employs High Temperature Pressure Transducers and Metered Water Injection

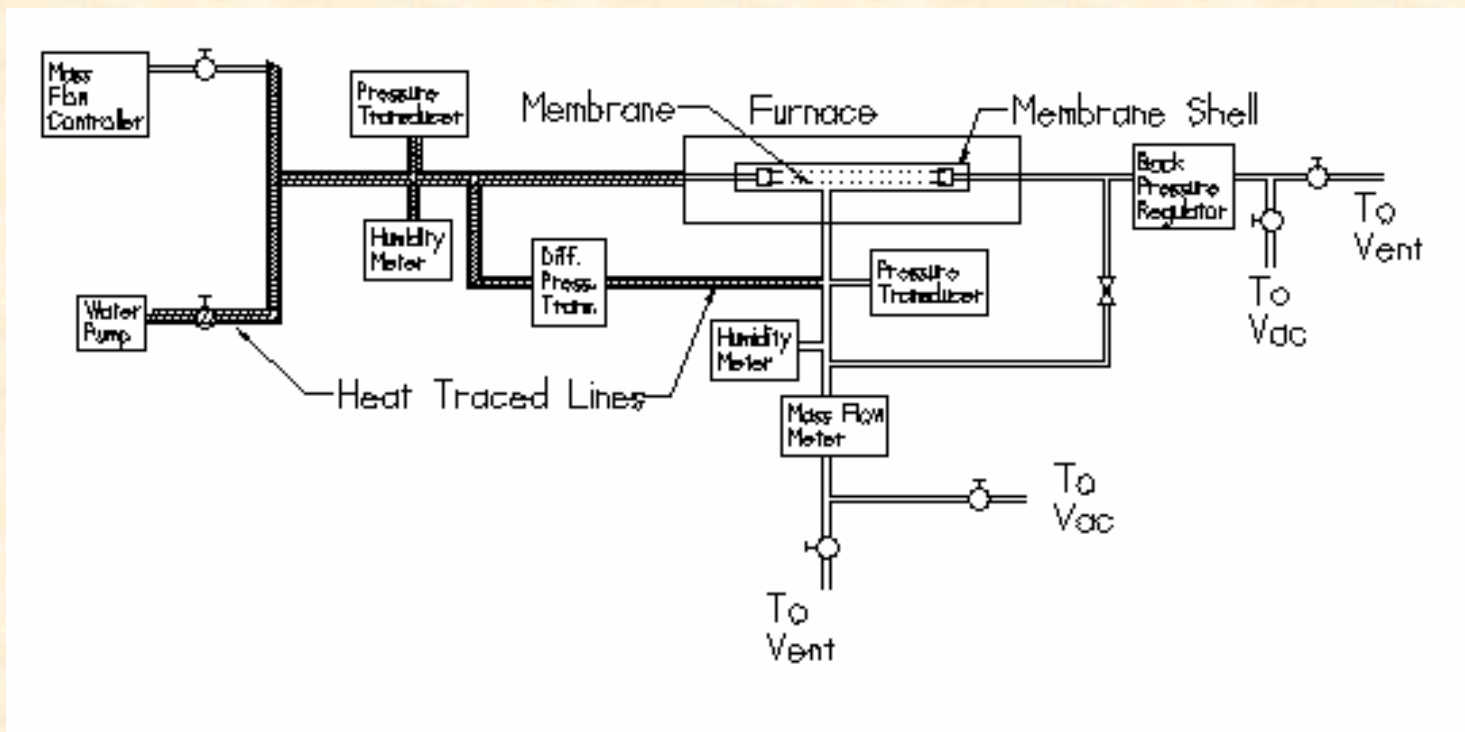

HTE Status

- Knudsen diffusion will yield a separation factor for hydrogen from steam of 3
- Knudsen membranes have very high fluxes.
- Knudsen membranes should be less expensive to manufacture and more thermally stable than microporous membranes used for SI process.
- Required purity can be achieved in 2 stages.
- A metal supported ceramic membrane was evaluated for the selectivity of helium from nitrogen and was found to achieve Knudsen selectivities.
- Preliminary separation tests on mixed gases achieved selectivities less than one would expect based on Knudsen diffusion. Results were believed to be caused by condensation of steam at pressure gauges.
- New test system has been designed. All components have been ordered and assembly has begun.

Plan for FY06

- **Make improvements in test system to avoid problems with condensation**
- **Test membrane at 800 °C**
- **Test membrane for long term operation of approximately 1000 hours**

Response to Reviewers' Comments

HTE

- It doesn't appear as though ultra-pure hydrogen will result even after a second process step. *The purpose of the project is to improve the economics of the high temperature electrolysis by sending un-reacted high temperature steam back to inlet of electrolyzer.*
- Water molecules are smaller than hydrogen molecules -- how will the hydrogen be removed from water? *Yes. Water is smaller than hydrogen but also much lighter. Separation occurs by Knudsen diffusion where the separation factor is the ratio of the molecular velocities.*

Sulfur-Iodine

- Why should permeance increase with temperature in the porous membranes? *When the pore-size of the membrane is less than 1 nm, a phenomenon call thermally activated diffusion promotes the flux of the smaller lighter molecules as the temperature increases. Because the flux increases faster for the smaller lighter molecules the separation factor increases also.*
- The challenge in this effort is finding suitable materials to perform as membranes with the ability to withstand the rigorous conditions of high temperatures and acid gas environments. *Yes. The acid gas environment is very aggressive. For this reason, material selection and evaluation is a very important task.*
- Add tasks to investigate the active membrane materials for the S-I process instead of concentrating just on the support tubes. *In general ceramic materials are much less susceptible to degradation by the acid environment than metals. However, metallic supports offer many advantages over ceramic supports when it comes to fragility and ability to seal into modules. The membrane separative layer will be made from a ceramic, most likely a metal oxide which should be more stable in the acid gas environment. Also, it is very difficult to evaluate the stability in this environment unless the membrane is applied to a stable support material. Plans do call for evaluating membrane materials when applied to suitable support materials.*