

V.E.3 Fuelcell-Powered Front-End Loader Mining Vehicle*

David L. Barnes (Primary Contact), Arnold R. Miller

Vehicle Projects, LLC

621 Seventeenth Street, Suite 2131

Denver, Colorado 80293-2101

Phone: (303) 296-4218; Fax: (303) 296-4219; E-mail: david.barnes@vehicleprojects.com

DOE Technology Development Manager: Sig Gronich

Phone: (202) 586-1623; Fax: (202) 586-9811; E-mail: Sigmund.Gronich@ee.doe.gov

Subcontractors:

AeroVironment Inc., Monrovia, California

Agnico-Eagle, Rouyn-Noranda, Quebec, Canada

CANMET, Ottawa, Ontario, Canada

Carleton University, Ottawa, Ontario, Canada

Caterpillar Inc., Peoria, Illinois

Caterpillar-Elphinstone, South Burnie, Tasmania, Australia

DRS Technologies, Hudson, Massachusetts

Hatch, Sudbury, Ontario, Canada

HERA Hydrogen Storage Systems, Longueuil, Québec, Canada

Modine Manufacturing, Racine, Wisconsin

Newmont Mining, Carlin, Nevada

Nuvera Fuel Cells, Cambridge, Massachusetts

Placer Dome Technical Services, Vancouver, British Columbia, Canada

Southwest Research Institute, San Antonio, Texas

Stuart Energy Systems, Mississauga, Ontario, Canada

University of Nevada, Reno, Nevada

Washington Safety Management Solutions, Aiken, South Carolina

** Congressionally directed project*

Objectives

- Develop a mine loader powered by a fuelcell
- Develop associated metal-hydride storage and refueling
- Demonstrate loader in an underground mine in Nevada

Technical Barriers

This project addresses the following technical barriers from the Technology Validation section of the Hydrogen, Fuel Cells and Infrastructure Technologies Program Multi-Year Research, Development and Demonstration Plan:

- A. Vehicles
- B. Storage
- C. Hydrogen Refueling Infrastructure

Approach

- Perform a cost/benefit analysis of fuelcell mine vehicles, including cost of producing hydrogen, method of hydrogen transfer, mine recurring costs, and ventilation savings

- Develop an electrolysis refueling station and demonstrate refueling concepts in Nevada
- Determine power requirements (duty cycle), drive system, whether a hybrid power train is appropriate, and onboard energy storage for a Caterpillar-Elphinstone R1300, 165 hp (123 kW), 3.5 cu. yd. mine loader
- Perform a detailed engineering design of powerplant, metal-hydride storage, drive system, and control system
- Fabricate powerplant and metal-hydride storage and bench test
- Integrate powerplant, metal-hydride storage, and system components into base vehicle
- Complete risk assessment and certify for underground demonstration
- Test entire vehicle and demonstrate in an underground mine in Nevada

Accomplishments

- Completed manufacturing of electrolyzer and demonstrated refueling concepts in Nevada with a fuelcell-powered mine locomotive
- Completed final reports for cost/benefit analysis, including “Best Methods of Hydrogen Transfer,” “Operating Costs of Hydrogen Production,” and “Ventilation Benefit Analysis”
- Received diesel-powered R1300 from manufacturer for verification of detailed component layout
- Completed 90% of detailed design of fuelcell powerplant, drive system, battery hybrid configuration, and metal-hydride storage system
- Performed a formal design review on all systems
- Received 90-kW fuelcell stacks from manufacturer
- Completed preliminary risk assessment

Future Directions

- Fabricate and test powerplant, metal-hydride storage, drive system components, hydraulic components, operating controls, and cooling components
- Integrate associated fuelcell-power components into R1300 base vehicle
- Test fuelcell systems against baseline diesel-powered performance parameters
- Complete risk assessment and underground certification with Mine Safety and Health Administration (MSHA)
- Evaluate performance and durability in an underground mine in Nevada

Introduction

Underground mining is the most promising application in which fuelcell vehicles can compete strictly on economic merit. The mining industry, one of the most regulated, faces economic losses resulting from the health and safety deficiencies of conventional underground traction power. Conventional power technologies — tethered (including trolley), diesel, and battery — are not simultaneously clean, safe, and productive. Solution of this problem by fuelcells would provide powerful cost offsets to the current high capital cost. Lower recurring costs, reduced ventilation costs, and higher

vehicle productivity could make the fuelcell mining vehicle cost-competitive several years before surface applications. The diesel-powered version of the loader is shown in Figure 1.

Approach

A joint venture between the Fuelcell Propulsion Institute (a nonprofit consortium of industry participants) and Vehicle Projects LLC (project management) provided the basis for this three-phase project, a key production element of underground mining. To ensure the design meets industry needs, various mining industry participants will evaluate



Figure 1. Diesel-Powered Mine Loader

and provide input regarding performance, productivity, and operator ergonomics.

The first phase of the project performed a cost/benefit analysis comparing diesel and fuelcell vehicle recurring costs, fuel costs, energy efficiency, and ventilation costs that determined the feasibility of commercialization. Different refueling concepts were verified by manufacturing an electrolyzer and using Vehicle Projects' fuelcell-powered mine locomotive. To understand all of the power requirements, a duty cycle, under real operating conditions, was established. This assisted in determining the type of drive motor, onboard energy storage, and that the powerplant would be a fuelcell-battery hybrid. Software modeling was used to understand the energy requirements needed to satisfy the duty cycle over an entire operating shift.

In Phase 2, detailed engineering design, project partners designed the powerplant, metal-hydride storage, hydraulic interface, cooling system, system controls, and layout. Engineering drawings and bill of materials will be the deliverables.

The final phase involves fabrication of the powerplant, metal-hydride storage, and all subsystems; integration into the base vehicle; testing of all systems; completion of risk assessment and certification for underground evaluation; and testing in a production mine in Nevada.

Results

Due to the nature of the duty cycle, the fuelcell powerplant module is designed as a fuelcell-battery

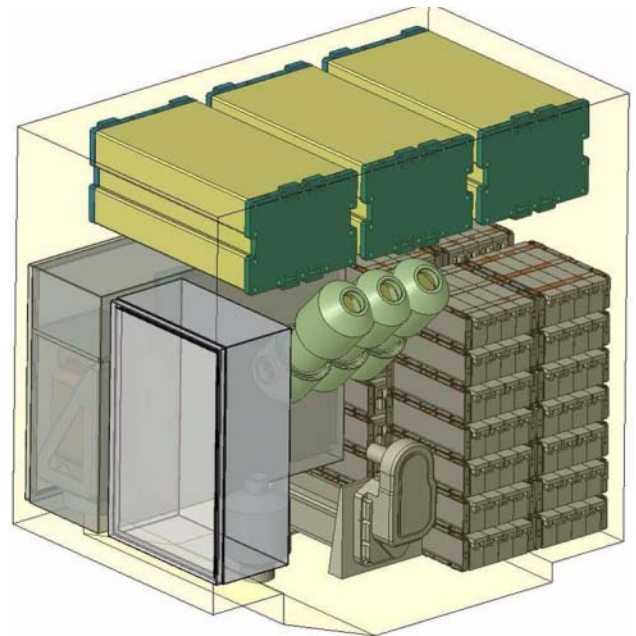

Figure 2. Fuelcell Powerplant Module



Figure 3. PEM Fuelcell Stacks

hybrid as shown in Figure 2. The module consists of three proton exchange membrane (PEM) fuelcell stacks (Figure 3) rated at 290 V, 300 A, 87 kW gross power along with 112 nickel metal-hydride (NiMH) batteries capable of an additional 65 kW for about 2 minutes. Peak power is thus about 140 kW net for short durations such as loading the bucket with ore and tramping up an incline.

Included in the fuelcell-power module is a system controller that will monitor power, temperature, pressures, and flow rates; an 80-kW

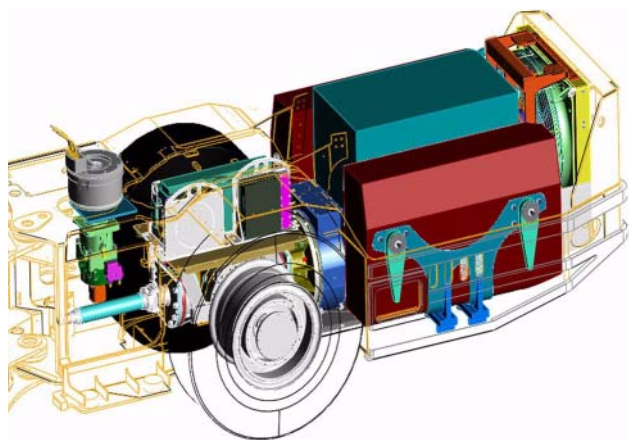

Figure 4. Fuelcell-Powered Loader Layout

DC/DC boost converter; an 8-kW bi-directional DC/DC power module capable of handling 24 V to 400 V; and a data acquisition system that will monitor every one of the 402 total cells of the fuelcell stacks.

The air compressor is a centrifugal supercharger design rotating at 171,000 rpm and delivering nearly 4,700 standard liters/minute at 1.8 bar pressure. The fuelcell stacks are cooled with de-ionized (DI) water flowing at 150 liters/minute to maintain the stack temperature between 65°C and 75°C. The DI cooling loop interfaces with the metal-hydride storage to supply heat to desorb the hydrogen from the metal hydride.

Figure 4 shows the overall layout of the fuelcell-powered loader. The fuelcell powerplant module sits in the middle of the metal-hydride storage, which is in a saddlebag configuration. The metal-hydride storage is removable so that in shaft mines the metal hydride can be taken to surface for refueling. Another major addition is the traction motor (situated in front of the fuelcell powerplant module). This is a brushless permanent magnet motor rated at 450 hp, 335 kW. This is more than the original diesel rating of 165 hp, 123 kW, and we will limit the power to the

motor so as not to overpower the loader. The traction motor will direct drive the propulsion shaft to the front wheels through the rear differential.

A preliminary risk assessment, facilitated by a professional engineering firm specializing in risk assessments and mine equipment, was performed to identify potential health and safety hazards. This extensive risk assessment covers all aspects of operation and will provide valuable information to the regulatory agencies such as MSHA. The risk assessment is ongoing and will conclude with the acceptance of the loader being demonstrated underground.

Conclusions

Great strides have been made in the detailed design of the fuelcell powerplant, metal-hydride storage, vehicle hydraulics and cooling subsystems, and in the risk assessment. Project members are starting the fabrication phase as the vehicle integrator finalizes the layout and placement of critical components. Because of the harsh operating environment of underground mines, special design considerations have been taken into account to minimize any release of hydrogen. The heating of the metal-hydride storage to desorb hydrogen will be closely monitored and controlled in order to have the amount of free hydrogen needed for the fuelcells to be at a minimum at any given time. This will mitigate the possible release of hydrogen to an acceptable and manageable level. Because of the stringent regulations for underground mines, metal-hydride storage is an ideal technology for the loader.

Presentations

1. A.R. Miller, "The Fuelcell Mining Vehicles Development Program: An Update", Canadian Institute of Mining Annual Conference & Exhibition, Montreal, Quebec (2003).