

### VII.K.3 Modeling and Control of an SOFC APU

*Moe A. Khaleel (Primary Contact), Xin Sun, Brian J. Koeppe, Ba Nghiep Nguyen, Ning Lu*

*Pacific Northwest National Laboratory*

*P.O. Box 999, MS K7-36*

*Richland, WA 99352*

*Phone: (509) 375-2438; Fax: (509) 375-4392; E-mail: moe.khaleel@pnl.gov*

*DOE Technology Development Manager: John Garbak*

*Phone: (202) 586-1723; Fax: (202) 586-9811; E-mail: John.Garbak@ee.doe.gov*

*Start Date: October 2004*

*Projected End Date: Project continuation and direction determined annually by DOE*

#### Objectives

- Task 1: Develop dynamic system model of a solid oxide fuel cell (SOFC)-based auxiliary power unit (APU) and design a system controller to minimize diesel fuel consumption, maximize operating lifetime, and satisfy electrical load requirements for Class VIII truck applications.
- Task 2: Develop predictive analytical models to assess the dynamic mechanical response and vibration limits of SOFC-based APU systems in a Class VIII truck operational environment.

#### Technical Barriers

This project addresses the following technical barriers from the Fuel Cells section of the Hydrogen, Fuel Cells and Infrastructure Technologies Program Multi-Year Research, Development and Demonstration Plan:

- A. Durability
- F. Fuel Cell Power System Integration
- G. Power Electronics
- J. Startup Time/Transient Operation

#### Technical Targets

This project is developing modeling tools that can assess electrical performance and mechanical durability for SOFC-based APUs. These predictive models will characterize system and component performance against the following DOE 2006 targets for 3-5 kW rated APUs:

- Specific Power: 70 W/kg
- Efficiency @ Rated Power: 25%
- Durability: 2000 hr
- Start-up Time: 30-45 min

#### Approach

##### Task 1

- Create transient thermal and electrochemical models to simulate the SOFC stack.
- Create dynamic operational models for power electronics and balance-of-plant components using first principles and experimental data.
- Combine component models in Simulink and design system controllers.
- Model validation through experimental testing and collaboration.

Task 2

- Develop models to capture the dynamic response of the APU and SOFC stack to mechanical vibrations.
- Implement constitutive and failure models for seal, anode, electrolyte, and cathode materials in the SOFC stress analysis model.
- Develop a probabilistic framework for component design sensitivity and identify sufficient isolation requirements for a characteristic APU/stack design.

**Accomplishments**Task 1

- Developed the SOFC stack electrochemical model based on experimentally obtained I-V relationships.
- Developed the lumped SOFC stack thermal model to capture thermal transients.
- Developed balance-of-plant models (e.g. combustor, heat exchanger).
- Developed and implemented the layered control logic using Simulink.
- Developed power electronics system architecture and model through collaboration with the University of Illinois.

Task 2

- Developed finite element models to characterize the dynamic and thermo-mechanical responses of the APU and SOFC stack to characteristic loads.
- Implemented constitutive models and failure criteria for fuel cell materials including fracture and damage models to analyze interfacial crack growth.
- Identified permissible accelerations for a planar SOFC stack.
- Developed a probabilistic framework for design sensitivity.

**Future Directions**Task 1

- Integrate power consumption unit model and develop a control strategy to regulate fuel supply.
- Optimize controller performance based on interactions between the cell, power electronics, and balance-of-plant.
- Experimentally validate simulation results of individual components and the APU.
- Design and manufacture prototype hardware for the control layer and interfaces.

Task 2

- Complete integration of fatigue damage model with stack analysis to determine cyclic loading limits for seal materials.
- Define isolation requirements for various SOFC and APU designs.
- Experimentally validate model predictions of APU response.

**Introduction**

Electrical power for long-haul trucks was traditionally provided by the engine, but many states have passed anti-idling legislation to reduce emissions. Dedicated diesel generator-based APUs eliminate the cost and wear of using the truck engine, but still have harmful emissions. Fuel cell-based

APUs can potentially provide greater energy efficiency, lower operating costs, lower emissions, and quieter operation. An SOFC is expected to be the choice for transportation applications because it has higher power density and offers fuel flexibility.

This project develops predictive modeling tools to characterize SOFC-based APU performance,

efficiency and durability. Task 1 investigates operational models of the APU system and components to study device interaction and efficiency of different topologies. The operational models are used to create effective control strategies to optimize fuel efficiency and durability during steady and transient loading. Task 2 provides modeling tools to evaluate the dynamic and thermal-mechanical responses of the APU under vibrational loading. Structural integrity of SOFC components is tenuous due to high temperatures and dissimilar material interfaces, especially with the rigorous dynamic loading of the heavy truck environment. These tools help designers define appropriate materials, cell design, physical layout, and isolation components to keep vibrational loading within acceptable levels to meet APU durability targets.

### **Approach**

Task 1: The approach to creating operational models of the APU components and system has been to combine theoretical operation with experimental data, keeping the models broadly applicable but realistic. Models for components such as the diesel reformer, heat exchangers, power electronics system (PES), battery, and SOFC stack are created in the modular Simulink environment that allows them to easily be connected in different configurations. This allows different fuel and thermal management strategies to be tested and evaluated. A layered control logic has been implemented which incorporates the individual component-level control modules. The controller is currently being integrated into the PES models to coordinate component interactions and to increase fuel efficiency and SOFC operating life for characteristic electrical load profiles.

Task 2: Previously, models for the APU and SOFC stack were developed to analyze the dynamic and thermal-mechanical responses of the components. Failure criteria including small-scale fracture models were used with stress analysis results to identify maximum permissible accelerations. In the past year, efforts focused on a seal damage model, fatigue crack growth, and a probabilistic approach to isolation design. Reliable SOFC sealing is still a technical challenge, and interfacial seal failures are expected under fatigue loading.

A damage model developed under the DOE Solid State Energy Conversion Alliance (SECA) core technology program to evaluate accumulated damage in glass-ceramic composites was enhanced to study interfacial crack propagation and extended to include cyclic loading. Predictions of component fatigue fracture were also implemented in the stress models using an assumed flaw geometry and Paris-type fatigue law. A probabilistic framework is also being developed to evaluate failure sensitivity of the fuel cell components and provide probabilistic estimates of a design's ability to meet technical targets.

### **Results**

#### **Task 1**

The system model created previously has been improved. The critical model developed in FY2005 is the dynamic electrochemical reaction model. The electrochemical output of the SOFC stack can be influenced by power load, fuel and oxidant gas flow rate, temperature and partial pressure of the reacting gases. The electrochemical dynamic model addresses these physical factors that influence the electrical output.

Thermal management is critical in maintaining the normal operation of a SOFC system which operates at temperatures ranging from 600°-1000°C. A stand-alone APU unit should be able to run with fuel and air supplied at their normal storage temperature, so the inflow gases need to be heated prior to being fed to the SOFC stacks. As a stand-alone unit, the APU system should be able to heat up the inflow gases using the energy generated by combustion of a portion of the inflow gases and/or the exhaust gases. Appropriate amounts of fuel and air heated to the working temperature should be guaranteed without any extra facilities other than the APU unit itself.

In order to fulfill the thermal management function, a combustor and two heat exchangers were integrated in the SOFC unit. The combustor produces hot gases with extremely high temperature using fuel and/or exhaust gases from the SOFC stacks. The hot gases are fed in the heat exchangers to heat up fuel and air respectively. To coordinate these individual components as an integrated unit,

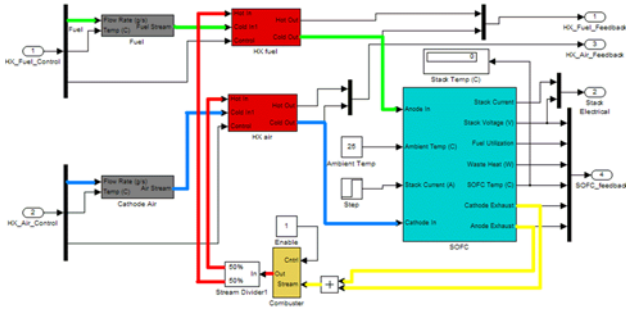

Figure 1. A Stand-Alone SOFC Unit Model

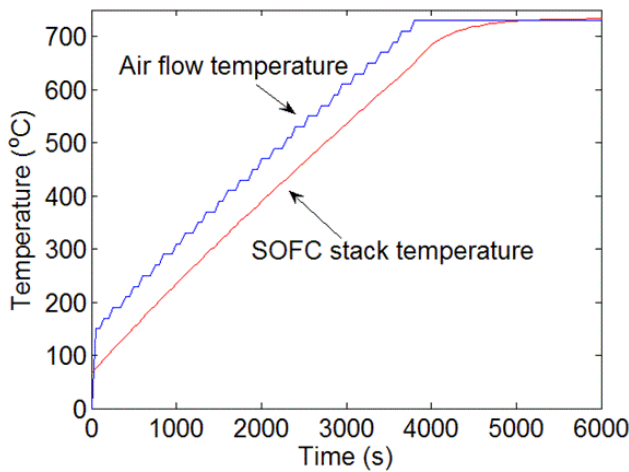

Figure 2. The Heat-Up Response of the SOFC

a control logic system was developed to monitor the normal working condition of the SOFC stack and regulate the combustor and heat exchangers. The Simulink model comprises four main parts: the SOFC stack model, the combustor model, the heat exchanger model, and the control logic layer (Figure 1). Sample dynamic responses of the system analyzed are shown in Figures 2-3.

**Task 2**

The modified boundary layer (MBL) analysis was extended to incorporate the damage model developed for glass-ceramic seals. This can determine the interface fracture toughness and damage accumulations leading to crack propagation as a function of local mode mixity, where the crack at the seal-electrolyte interface could grow along the interface or into the seal (Figure 4). The model was also applied to evaluate the seal-interconnect interface where a chemical reaction creates a

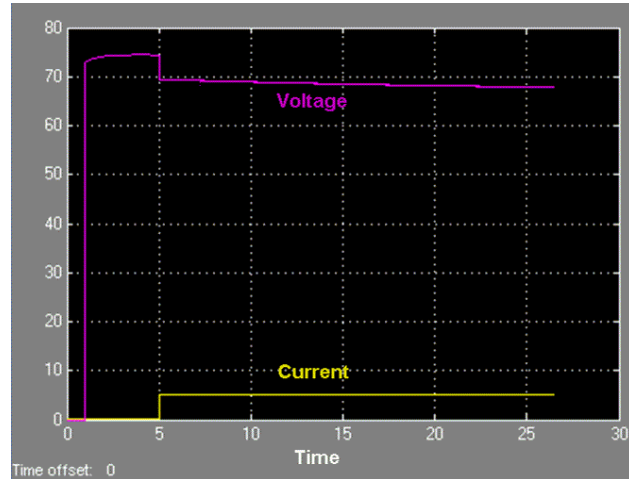

Figure 3. SOFC Electrical Response to a Current Step Load

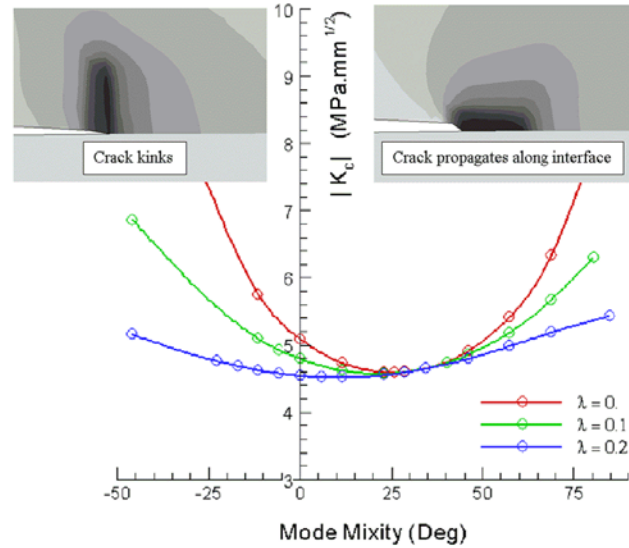
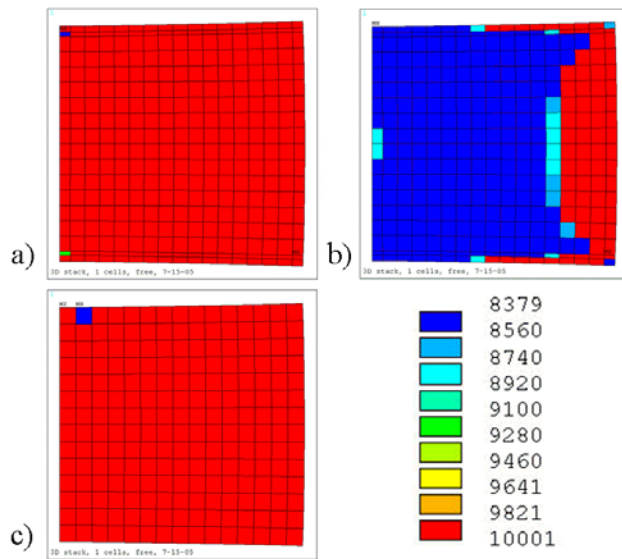

Figure 4. Variation of the G18/YSZ interface toughness as a function of mode mixity and contribution of shear. The crack may propagate along the interface or kink into the seal material.

secondary phase. The effects of graded properties, porosity and sensitivity to shear were evaluated. The damage model was then extended to include the elastic-plastic and cyclic behaviors of glass-ceramic seals. An elastic-plastic damage model was formulated for monotonic loading and implemented in the MBL analysis. A fatigue damage model was then formulated that accounts for fatigue damage in addition to quasi-static damage under cyclic loading, and model implementation is in progress.

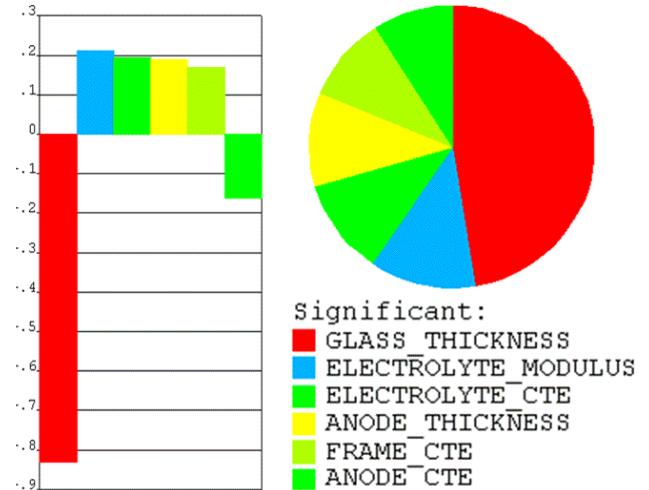

**Figure 5.** Example predicted lifetime for the a) anode, b) electrolyte, and c) cathode based on growth of an initial surface crack through the component layer. The electrolyte does not meet a 10,000 hour target.

Additionally, the traditional method of using an assumed flaw and a Paris-type growth law was used to estimate cell lifetimes from the stress results against technical targets (Figure 5). A probabilistic framework was also created to evaluate design sensitivity of failure for different geometries. A direct Monte Carlo approach to evaluate component failure criteria as function of design geometry and material variations was implemented (Figure 6) and is currently being used with material property distributions to assess reliability. Additional material model improvements were implemented such as temperature-dependent damping characteristics for fuel cell materials obtained from internal friction measurements in the literature.

### Summary

- **Task 1:** State-of-the-art models of an SOFC-based APU system and components were developed to describe the dynamic transient behavior of the SOFC stack. The Simulink model contains a control layer that was used to regulate and coordinate the individual components, and sample dynamic responses of the model were analyzed. The models were used to develop controllers to provide required current and maintain fuel utilization under varying



**Figure 6.** Sensitivity of the maximum principal stress in the electrolyte to various geometric and material parameters.

electrical loads. A detailed power electronic model was provided by the University of Illinois and incorporated. Further controls improvements will be performed on the interactions of the fuel cell, power electronics, and balance-of-plant components.

- **Task 2:** A modeling framework for vibration and shock analyses of an SOFC-based APU was created which determines permissible accelerations based on multiple failure criteria including interfacial failure and fatigue loading. A probabilistic framework was developed to identify design sensitivities and is currently being used to ensure isolation is appropriate to meet technical targets.

### FY 2005 Publications/Presentations

1. B.N. Nguyen, B.J. Koepfel, S. Ahzi, M.A. Khaleel, and P. Singh, "Crack Growth in Solid Oxide Fuel Cell Materials: From Discrete to Continuum Damage Modeling," submitted for publication.
2. N. Lu, Q. Li, Y. Xie, X. Sun, B.J. Koepfel, and M.A. Khaleel, "Dynamic Modeling in Solid-Oxide Fuel Cells Controller Design," submitted for publication.
3. B.N. Nguyen, B.J. Koepfel, and M.A. Khaleel, "From a Discrete to Continuum Damage Mechanics Model of Crack Growth in Solid Oxide Fuel Cell Materials" the 2005 ASME Mechanics and Materials Conference (McMat 2005), Proceedings of McMat 2005, paper #24.

4. M.A. Khaleel, X. Sun, N. Lu, B.J. Koeppel, B.N. Nguyen, and S. Mazumder, "Modeling and Control of an SOFC APU," Hydrogen Program 2005 Annual Merit Review Meeting, Arlington, VA (2005).