

## II.A.1 Investigation of Reaction Networks and Active Sites in Bio-Ethanol Steam Reforming over Co-Based Catalysts

Umit S. Ozkan (Primary Contact),  
I. Ilgaz Soykal, Burcu Mirkelamoglu,  
Xiaoguang Bao  
Department of Chemical & Biomolecular Engineering  
The Ohio State University  
125 Koffolt Laboratories  
140 W. 19<sup>th</sup> Ave.  
Columbus, OH 43210  
Phone: (614) 292-6623  
E-mail: ozkan.1@osu.edu

DOE Technology Development Manager:  
Rick Farmer  
Phone: (202) 586-1623  
E-mail: Richard.Farmer@ee.doe.gov

DOE Project Officer: Paul Bakke  
Phone: (303) 275-4916  
E-mail: Paul.Bakke@go.doe.gov

Contract Number: DE-FC36-05GO15033

Project Start Date: May 1, 2005  
Project End Date: December 31, 2010

### Objectives

To develop precious metal-free catalysts that can operate at lower temperatures with high yields and selectivities for hydrogen steam reforming from bio-ethanol; acquire a fundamental understanding of the reaction networks, active sites and deactivation mechanisms of potential bio-ethanol steam reforming catalysts. More specifically:

- Determine the effect of catalyst synthesis methods on oxidation state, structure, metal dispersion, and particle size of cobalt-based bio-ethanol reforming catalysts using the following techniques:
  - Aqueous or organic impregnation
  - Co-precipitation
  - Sol-gel synthesis
  - Organometallic synthesis
  - Colloidal templating
  - Control of calcination and reduction conditions
- Determine oxidation states and chemical structures that are present in active catalysts that are exposed to:
  - Varying pre-treatment protocols
  - Differing levels of steam-to-carbon ratio during reaction

- Oxidative and auto thermal operation
- Different space velocities
- To study how the observed catalyst characteristics influence the reaction pathways for:
  - Oxygenate formation
  - Reverse water-gas shift
  - Alkane and olefin formation
  - Coke deposition
  - Steam reforming
- Determine how the chosen support material can influence metal dispersion and structure, and how it participates in:
  - Alcohol and water adsorption
  - Spillover of species
  - Intermediate and product formation
- Determine methods that can tailor the catalyst surface for optimum selectivity and activity by:
  - Surface acidity control
  - Chemical promotion
  - Active site density control
- Determine factors that degrade catalyst stability and optimize regeneration methods:
  - Pathways and active sites for coke formation
  - Loss of surface area under reaction
  - Metal-support interaction
  - Sintering

### Technical Barriers

This project addresses the following technical barriers from the Production section (3.1.4) of the Fuel Cell Technologies Program Multi-Year Research, Development and Demonstration Plan:

- (A) Reformer Capital Costs
- (C) Operation and Maintenance (O&M)
- (D) Feedstock Issues

### Technical Targets

This is a university project, which involves a systematic and detailed study aimed to provide fundamental answers to questions that are not readily solved in an industrial setting. The approach is an iterative one that combines catalyst synthesis, characterization and reaction engineering studies. The results of this study will prevent interpreting erroneous information resulting from the screening of a large

catalyst matrix by characterizing the parameters that lead to or inhibit the formation of active sites for reforming. The information obtained from this study will address many common problems associated with catalyst development, such as choice of materials, pre-treatment conditions, and factors controlling active site distribution, stability, and selectivity. Insights gained from these studies will be applied toward the design and synthesis of cost-effective and efficient reforming technologies that meet the DOE 2012 technical targets for hydrogen from bio-derived renewable liquids. Specific technical targets that would benefit from this study are the following:

- Production Energy Efficiency: 72.0%
- Contribution of Production to Capital Cost: 0.45 (\$/gasoline gallon equivalent, gge)
- Total Hydrogen Cost from bio-derived liquids: 3.80 (\$/gge)

### Accomplishments (most recent)

- An advanced X-ray spectroscopy technique, X-ray absorption fine structure spectroscopy (XAFS), that allows monitoring of the transformation of cobalt species during ethanol steam reforming was added to the arsenal of techniques that are being utilized to characterize the developed catalyst formulations under real working conditions.
- In situ XAFS studies provided insight to the changes in the oxidation state and local coordination environment of cobalt species during ethanol steam reforming which would, in turn, result in ease of operation with the elimination catalyst pre-treatment step.
- The use of in situ infrared spectroscopy led to the identification of reaction intermediates under actual reaction conditions of ethanol steam reforming which solidified the understanding of the reaction mechanism.



### Introduction

For hydrogen energy to fulfill its potential for protecting the environment, providing more efficient energy sources, and decreasing our nation's dependence on foreign oil, we need economical and efficient technologies for hydrogen production from renewable energy sources. Hydrogen production from ethanol through steam reforming lends itself very well to a distributed hydrogen production strategy and hence has the potential to offer solutions to problems associated with hydrogen storage and infrastructure. The bio-ethanol produced by fermentation of biomass can yield an ethanol-water mixture already ideal for reforming

without additional distillation steps. A review of the ethanol steam reforming literature shows that there is no consensus about an optimal catalyst, and a fundamental understanding of the relationships between catalytic properties and how these properties are affecting various reaction steps involved in this complex network is lacking.

The development of non-precious metal catalysts in this project will reduce the catalyst cost, while the lower operation temperatures will reduce the material cost for reactor systems and will also reduce the energy requirement for heating the feed mixture to high reaction temperatures. The catalyst will have high steam reforming activity, while being non-selective for various undesired side reactions, such as methanation, dehydration, dehydrogenation, coking, and reverse water-gas shift reaction. The high yields to be achieved will help increase the production energy efficiency. The catalytic system will have high stability and well-understood regeneration mechanisms. High stability will reduce catalyst cost by prolonging the active life span of the catalyst. The regeneration mechanisms will be useful in reactivating the catalyst, rather than discarding the deactivated catalyst. The design of such catalysts will not be possible without a thorough understanding of the relationships between the catalyst preparation parameters, their structural and molecular characteristics and their reaction performance. The understanding acquired through this study will eliminate the need for costly trial-and-error efforts and will enable design of catalytic systems with the desired characteristics.

### Approach

The project encompasses examination of the cobalt-based catalyst system at every stage of its life history, from precursor stage to activation, deactivation and regeneration steps. The techniques used include catalyst synthesis studies, transient and steady-state reaction tests, and characterization using surface, bulk and molecular analysis techniques (both ex situ and in situ) such as X-ray photoelectron spectroscopy, laser Raman spectroscopy, diffuse reflectance infra-red Fourier transform spectroscopy (DRIFTS), transmission electron microscopy, X-ray diffraction, thermal gravimetric analysis, differential scanning calorimetry, temperature-programmed reduction, temperature-programmed oxidation, temperature-programmed desorption (TPD) and most recently, XAFS. The approach taken is not a consecutive execution of the tasks or steps in each task, but rather an iterative approach where the findings in one aspect of the study are utilized in a feedback mechanism to plan and modify the steps taken in another task. Understanding gained through molecular simulations is utilized in tailoring the catalyst surfaces for better performance.

## Results

The activities during this reporting period focused on determination of the local coordination environment and oxidation state of cobalt-based catalyst formulations via XAFS spectroscopy. The project had multiple sessions of beam time at the Dow-Northwestern-DuPont Collaborative Access Team bending magnet beam line (5BM-D) at the Advanced Photon Source of Argonne National Laboratory. The primary focus of the XAFS studies was investigation of the effect of pretreatment conditions on the nature of cobalt species in efforts to improve the ease of operation and to shed light to the ongoing debate on the nature of the cobalt active sites in the bio-ethanol steam reforming literature.

XAFS spectra of Co/CeO<sub>2</sub> catalyst following oxidation and reduction pretreatment is shown in Figure 1 together with the XAFS spectra for cobalt (II) oxide and cobalt (II, III) oxide used as standards. Figure 1 clearly shows that the coordination environment of cobalt species in Co/CeO<sub>2</sub> catalyst closely resembles that of cobalt (II, III) oxide following oxidation treatment. Following reduction treatment cobalt species were reduced to a lower oxidation state that closely resembles cobalt (II) oxide. Figure 1 also shows the XANES fit for oxidized and pre-reduced Co/CeO<sub>2</sub> catalysts which have

undergone ethanol steam reforming (ESR) for 1-hour at the designated temperature. A comparison of the oxidation states of cobalt species following ESR over the pre-oxidized and pre-reduced samples clearly showed that regardless of the pretreatment procedure the same type of cobalt species were present in almost the same proportions over both of the catalysts.

In addition to the XAFS technique for studying the active cobalt species during reaction conditions, the interactions of ESR reactants, intermediates and products were studied under ESR conditions using in situ DRIFTS spectroscopy. Although DRIFTS technique has been used extensively in the project to investigate the thermal evolution of surface species following the room-temperature adsorption of reactants and reaction intermediates (DRIFTS-TPD), these in situ reaction DRIFTS experiments allowed monitoring of the transformation of reactants and especially less stable surface intermediates under reaction conditions. The DRIFTS data collected during reaction were combined with spectra collected during purging for a detailed identification of surface species. Figure 2 shows such a pair of DRIFTS data as a function of temperature for a 10% Co/CeO<sub>2</sub> catalyst during ESR and subsequent purge steps. The 1,731 cm<sup>-1</sup> band observed in the spectra collected in situ during ESR above 150°C is of particular

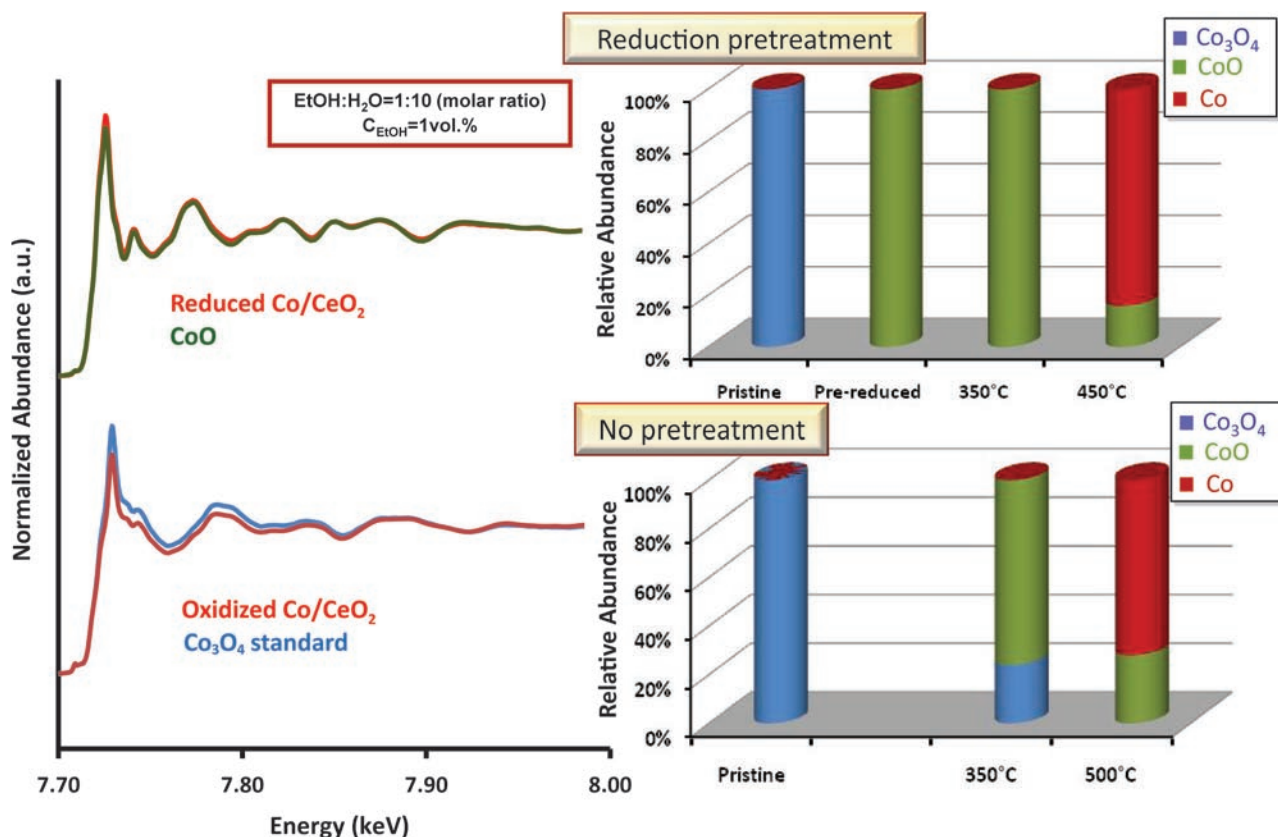

FIGURE 1. Comparison of XAFS Spectra for Reduced and Oxidized Co/CeO<sub>2</sub> Samples

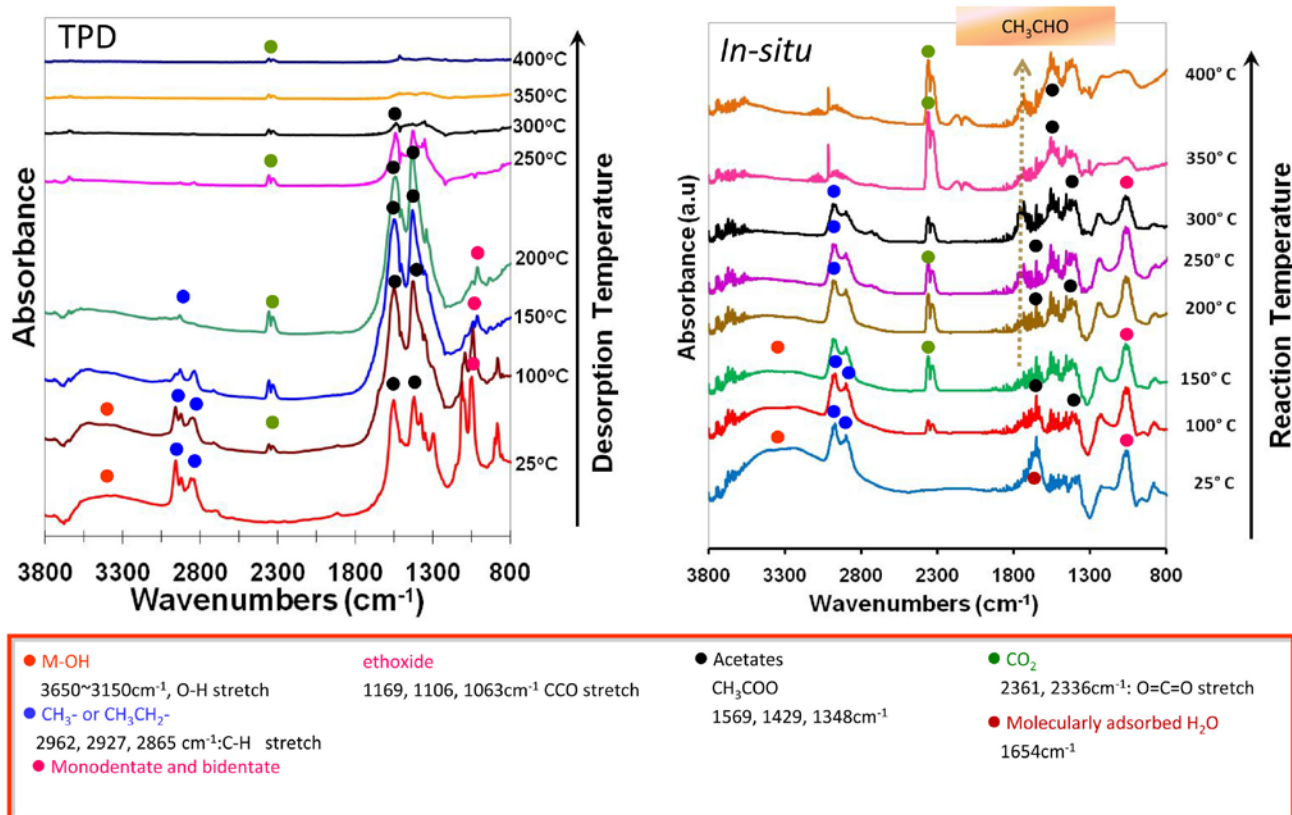

FIGURE 2. Comparison of In Situ DRIFT Spectra Collected during Ethanol TPD and Steam Reforming over  $\text{Co/CeO}_2$

importance since it signifies adsorbed acetaldehyde [1-7]. Although in our steady-state reaction experiments, acetaldehyde was observed as a reaction product, it was not detected in the transient experiments or in the TPD experiment. It is highly likely that these species interact weakly with the surface and get flushed away during the purge, and therefore, the DRIFTS-TPD profiles failed to show the presence of aldehyde species on the surface. Along with the ethoxy groups detected on the surface, this finding provided further evidence for the previously proposed ethanol steam reforming reaction mechanism where an ethanol-to-ethoxy-to-acetaldehyde pathway was proposed to be the initial steps for hydrogen production in bio-ethanol steam reforming (Figure 3).

This year's work also involved preliminary studies with different feedstocks such as dimethylether (DME). DME is an inert, non-carcinogenic, non-corrosive, non-mutagenic and virtually non-toxic alternative to ethanol. Moreover, it is possible to liquefy DME at  $0^\circ\text{C}$  and 6 psig which makes it a versatile feedstock for industrial applications. The DRIFTS spectra presented in Figure 4 shows operando DME steam reforming over a 10%  $\text{Co/CeO}_2$  catalyst. Strong bands associated with methoxide species, which persisted throughout the investigated temperature range of  $25\text{-}400^\circ\text{C}$  were observed. Furthermore, the presence absorption bands

in the  $1,250\text{-}1,100\text{ cm}^{-1}$  region pointed to the presence of formates [8].  $\text{Co/CeO}_2$  catalyst showed strong single carbon adsorption bands on the surface, which were observed throughout the temperature program in steam reforming conditions.

## Conclusions and Future Directions

- New collaboration was initiated with the Argonne National Laboratory.
- Local coordination environment and oxidation state of cobalt over the cobalt-based ESR catalysts were determined via XAFS.
- The role of catalyst pre-treatment was examined by XAFS.
- Operando vibrational spectroscopy techniques were shown to provide new insights into the reaction mechanism.
- Alternative feedstocks such as DME were introduced.
- Collaborative molecular simulation work using density functional theory calculations will be performed and used to guide rational catalyst design.

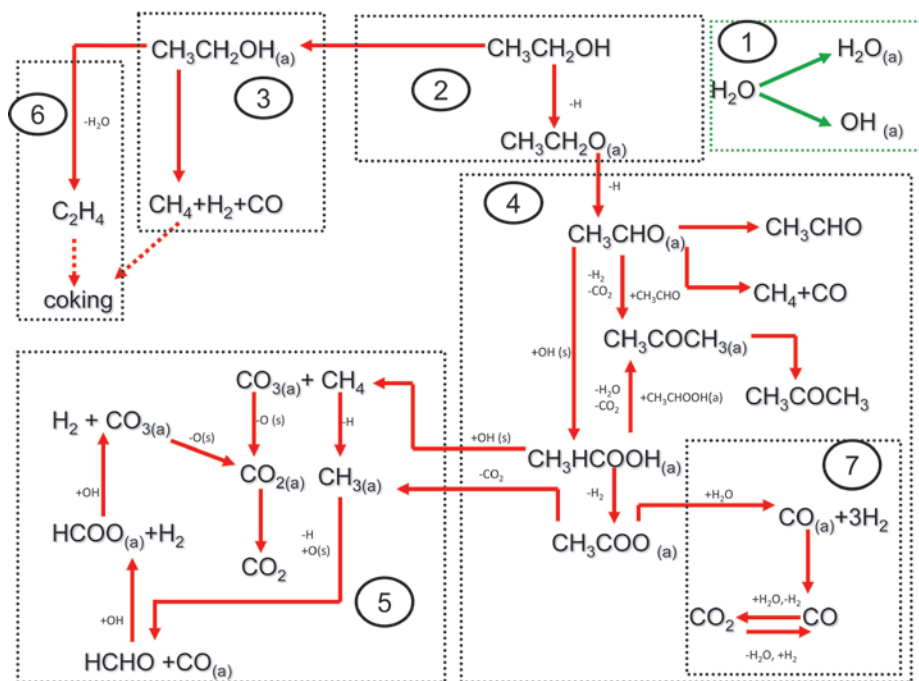

FIGURE 3. The Proposed Reaction Mechanism

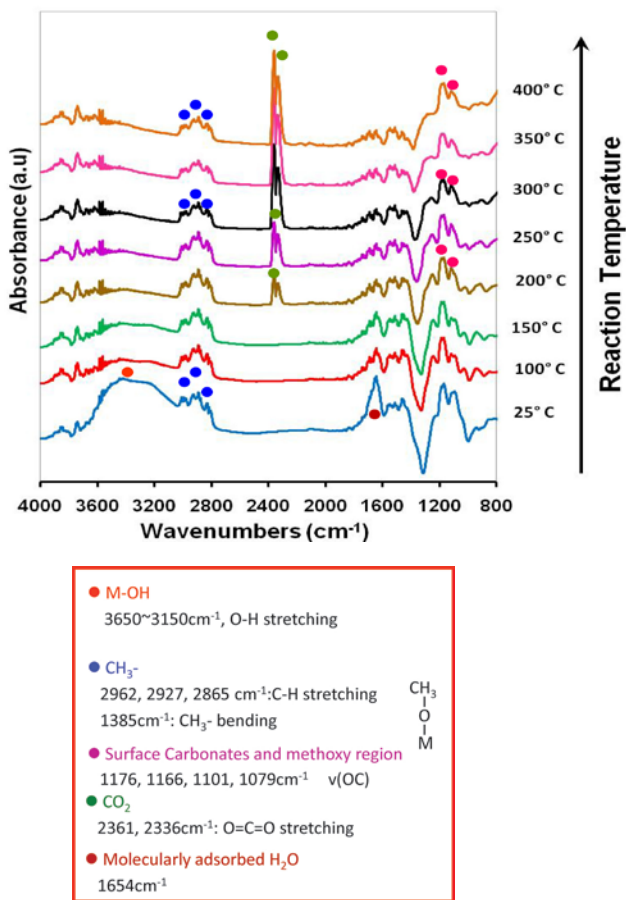

FIGURE 4. In Situ DRIFT Spectra Collected during DME Steam Reforming over 10%Co/CeO<sub>2</sub>

### Special Recognitions & Awards/Patents Issued

1. Ozkan, U.S., 2009 American Institute of Chemical Engineers WIC Mentorship Excellence Award.

### FY 2010 Publications/Presentations

#### Books

1. *Design of Heterogeneous Catalysts: New Approaches based on Synthesis, Characterization and Modeling*, Ed. U.S. Ozkan, Wiley-VCH, 2009.

#### Journal Articles

- Song, H., Ozkan, U.S., "Ethanol Steam Reforming over Co-based Catalysts: Role of Oxygen Mobility" *Journal of Catalysis*, **261** 66-74 (2009).
- Song, H., Tan, B., Ozkan, U.S., "Novel Synthesis Techniques for Preparation of Co/CeO<sub>2</sub> as Ethanol Steam Reforming Catalysts, *Catalysis Letters*, **132**, 422-429 (2009).
- Song, H. and Ozkan, U.S., "Economic Analysis of Hydrogen Production through a Bio-ethanol Steam Reforming Process: Sensitivity Analyses and Cost Estimations". *International Journal of Hydrogen Energy*, **35**, 127-134 (2010).
- Song, H. and Ozkan, U.S., "The Role of Impregnation Medium on the Activity of Ceria-supported Co Catalysts for Ethanol Steam Reforming," *J. Molecular Catalysis*, **318**, 21-29 (2010).

5. Song, H. Ozkan, U.S., “Changing the Oxygen Mobility in Co/Ceria Catalysts by Ca Incorporation: Implications for Ethanol Steam Reforming,” Invited paper. *Journal of Physical Chemistry A*. **114**, 3796-3801 (2010).
6. Woods, M. P. Gawade, P., Tan, B. Ozkan, U.S., “Preferential Oxidation of Carbon Monoxide on Co/CeO<sub>2</sub> Nano-particles” *Journal of Applied Catalysis B*, **97**, 28-35 (2010).
7. Song, H., Mirkelamoglu, B., and Ozkan, U.S., “Effect of Cobalt Precursor on the Performance of Ceria-Supported Cobalt Catalysts for Ethanol Steam Reforming,” *Applied Catalysis A*. **382**, 58-64 (2010).
8. Song, H., Zhang, L., Ozkan, U.S., “Reaction Networks in Ethanol Steam Reforming over Supported Co Catalysts” *Industrial and Engineering Chemistry Research*, accepted.
9. Song, H. and Ozkan, U.S., “Adsorption/desorption Behavior Ethanol Steam Reforming Reactants and Intermediates over Supported Cobalt Catalysts,” *Catalysis Letters*, Submitted.

### Conference Presentations

1. Song, H., Ozkan, U.S., “Hydrogen Production from Steam Reforming of Bio-Ethanol over Non-Precious Metal Catalysts,” 21<sup>st</sup> Meeting of the North American Catalysis Society, San Francisco, CA, June 2009.
2. Bao, X., Song, H., Hadad, C.M., Ozkan, U.S., “Computational Study of the Ethanol Steam Reforming Reaction over Co/CeO<sub>2</sub>(111): from Ethanol to Acetate” 238<sup>th</sup> ACS National Meeting, Washington, D.C., August 2009.
3. Song, H., Bao, X., Hadad, C.M., Ozkan, U.S., “Investigation of the Surface Reaction Mechanism in Ethanol Steam Reforming over Supported Co Catalysts” AIChE Annual Meeting, Nashville TN, November 2009.
4. Soykal, I.I., Mirkelamoglu, B., Ozkan, U.S., “Formation of Surface Species under Bio-Derivable Liquid Steam Reforming Conditions” poster presentation, Ohio Innovation Summit, April 2010.
5. Soykal, I.I., Mirkelamoglu, B., Bao, X., Hadad, C., Ozkan, U.S., “Catalytic Steam Reforming of bio-derived Oxygenates,” Presented at International Conference on Catalysis for Renewable Sources: Fuels, Energy, Chemicals, St. Petersburg, Russia, July 2010.

### Invited Lectures

1. “Energy Challenges of the Future: Opportunities and Solutions Chemical Engineers can Offer,”. KEYNOTE. 9<sup>th</sup> National Chemical Engineering Conference , Ankara Turkey, June 2010.

### References

1. Singh, M., Zhou, N., Paul, D.K., Klabunde, K.J., “IR Spectral Evidence of Aldol Condensation: Acetaldehyde Adsorption over TiO<sub>2</sub> Surface”, *Journal of Catalysis*, Vol. 260, pp. 371-379, 2008.
2. Busca, G., *Catalysis Today* Vol. 27 pp. 323-352, 1996.
3. Idriss, H., Diagne, C., Hindermann, J.P., Kiennemann, A., Barteau, M.A., “Reactions of Acetaldehyde on CeO<sub>2</sub> and CeO<sub>2</sub>-Supported Catalysts”, *Journal of Catalysis*, Vol. 155, pp. 219-237, 1995.
4. Llorca, J., Homs, N., Sales, J., Fierro, J.G., Piscina, P.R., “Effect of sodium addition on the performance of Co-ZnO-based catalysts for hydrogen production from bioethanol”, *Journal of Catalysis* Vol. 222 pp. 470-480, 2004.
5. Coates, J., *Interpretation of Infrared Spectra, A Practical Approach*, *Encyclopedia of Analytical Chemistry*, 2000.
6. Yamada, Y., Mathew, T., Ueda, A., Shioyama, H., Kobayashi, T., “A Novel DME Steam-Reforming Catalyst Designed with Fact Database On-Demand”, *Applied Surface Science*, Vol. 252, pp. 2593-2597, 2006.
7. Lin, S.S.-Y., Kim, D.H., Ha, S.Y., “Metallic Phases of Cobalt-Based Catalysts in Ethanol Steam Reforming: The effect of Cerium Oxide”, *Applied Catalysis A: General*, Vol. 355 pp. 69-77, 2009.
8. Evin, H.N., Jacobs, G., Martinez, J.R., Graham, U.M., Dozier, A.; Thomas, G., Davis, B.H., “Low Temperature Water-Gas Shift/Methanol Steam Reforming: Alkali Doping to Facilitate the Scission of Formate and Methoxy C-H Bonds over Pt/ceria Catalyst “, *Catalysis Letters*, Vol. 122, pp. 9-19, 2008.