

VIII.3 Hydrogen Safety, Codes and Standards: Sensors

Eric L. Brosha¹ (Primary Contact), William Penrose³, Leta Woo², Robert S. Glass² (Secondary Contact), Tommy Rockward¹, and Rangachary Mukundan¹

¹Los Alamos National Laboratory (LANL)

MS D429, P.O. Box 1663

Los Alamos, NM 87545

Phone: (505) 665 4008

Email: brosha@lanl.gov

²Lawrence Livermore National Laboratory (LLNL)

L-103, P.O. Box 808, 7000 East Avenue

Livermore, CA 94550

Phone: (925) 423 7140

Email: glass3@llnl.gov

³Custom Sensor Solutions, Inc.

11786 N. Dragoon Springs Drive

Oro Valley, AZ 85737

Phone: (520) 544-7523

Email: wpenrose@customsensorsolutions.com

DOE Manager

Will James

Phone: (202) 287-6223

Email: Charles.James@ee.doe.gov

Project Start Date: October 1, 2008

Project End Date: Project continuation and direction determined annually by DOE

Overall Objectives

- Develop a low-cost, and low-power electrochemical hydrogen safety sensor for a wide range of infrastructure and vehicle applications with focus on high durability and reliability
- Continually advance test prototypes guided by materials selection, sensor design, electrochemical R&D investigation, fabrication, and rigorous life testing
- Disseminate packaged sensor prototypes and control systems to DOE laboratories and commercial parties interested in testing and fielding advanced prototypes for cross-validation
- Evaluate manufacturing approaches for commercialization
- Engage an industrial partner and execute technology transfer

Fiscal Year (FY) 2014 Objectives

- Identify operating H₂ refueling station partners in California for placement of first field trial unit(s)

- Compose field trials plan of action/indemnity agreement for commercial partners
- Design new integrated control/signal electronics and National Electrical Manufacturers Association (NEMA)-compliant packaging for field trials deployment
- Obtain commercial-off-the-shelf data wireless data system and pre-test field trials system in the laboratory for remote sensor interrogation
- Develop control software for sensor control, data logging, event logging
- Test first field trials unit and prepare for locating on site

This project addresses the following technical barriers from the Safety, Codes and Standards section of the Fuel Cell Technologies Office Multi-Year Research, Development, and Demonstration Plan:

- (A) Safety Data and Information: Limited Access and Availability
- (C) Safety is Not Always Treated as a Continuous Process
- (K) No Consistent Codification Plan and Process for Synchronization of R&D and Code Development
- (L) Usage and Access Restrictions

Technical Targets

Technical targets vary depending on the application [1,2], but in general include:

- Sensitivity: 1-4 vol% range in air
- Accuracy: $\pm 1\%$ full scale in the range of 0.04-4 vol %
- Response Time: <1 min at 1% and <1 sec at 4%; recovery <1 min
- Temperature operating range: -40°C to 60°C
- Durability: Minimal calibration or no calibration required for over sensor lifetime (as defined by particular application)
- Cross-Sensitivity: minimal interference to humidity, H₂S, CH₄, CO, and volatile organic compounds

FY 2014 Accomplishments

- Demonstration hydrogen refueling sites in California were identified, and approved by station operators for test, and preparations to begin field trials development and testing commenced.
- Codes and standards guided planning for field trials work.
 - LLNL indemnity agreement written with Class 1/Div 2 standards used as guidance.

- LANL and Custom Sensor Solutions developed new electronics specifically for field trials units.
 - Packaged sensor mounts directly to impedance buffer circuit and heater control circuit simplified and optimized specifically to commercially prepared sensor substrate element (ESL ElectroScience, Inc.).
- Field trials unit designed to use commercial, off-the-shelf wireless transmitters/receivers to simplify deployment at testing site.
- A certified LabVIEW developer identified to provide data logging software (Agile Engineering/Zircoa Inc.)
 - Provisions to wirelessly log sensor output for up to three sensors simultaneously. User defined sampling rate, averaging, recording rate, and event threshold triggering.
- LANL conducted a site survey at Hydrogen Frontier LLC (Burbank) and identified desirable areas to locate field trial units. The best location was found to be inside the enclosure for the dispensing island. Known area of leaks and the housing is the location one of the filling station's commercial H₂ sensors.
- LLNL researchers surveyed AC Transit site and preparations for on-site testing were made. Testing at the AC Transit site did not go forward.
- NEMA-8 enclosures identified and internal layout fixed of field trials units.
- Five Custom Sensor Solutions sensor boards acquired in FY 2014 along with enough wireless units and NEMA-8 enclosures to assemble up to three test units by the end of FY 2014.



INTRODUCTION

Recent developments in the search for sustainable and renewable energy coupled with the advancements in fuel cell-powered vehicles have augmented the demand for hydrogen safety sensors initially to be placed at refueling sites and developed for incorporation onboard vehicles [2]. There are several sensor technologies that have been developed to detect hydrogen, including deployed systems to detect leaks in manned space systems and hydrogen safety sensors for laboratory and industrial usage. Among the several sensing methods commercially available or under development, electrochemical devices that utilize high-temperature-based ceramic electrolytes have been shown to be robust, potentially low cost, have high sensitivity and good selectivity, the latter exemplified by tolerance to changes in humidity, and are more resilient to electrode or electrolyte poisoning [3-9]. The desired sensing technique should meet a detection threshold of 1% (10,000 ppm) H₂ and response time of ≤1 min [10], which

is a target for infrastructure and vehicular uses. Further, a review of electrochemical hydrogen sensors by Korotcenkov et. al [11] and the report by Glass et al. [10,12] suggest the need for inexpensive, low-power, and compact sensors with long-term stability, minimal cross-sensitivity, and fast response. This view has been largely validated and supported by the fuel cell and hydrogen infrastructure industries by the NREL/DOE Hydrogen Sensor Workshop held on June 8, 2011 [13]. Many of the issues preventing widespread adoption of best-available hydrogen sensing technologies available today outside of cost, derive from excessive false positives and false negatives arising from unstable sensor baseline; both of these problems necessitate the need for unacceptable frequent calibration [13].

As part of the Hydrogen Codes and Standards project, LANL and LLNL are working together to develop and test inexpensive, zirconia-based, electrochemical (mixed potential) sensors for hydrogen detection in air. Previous work conducted at LLNL showed [9] that indium tin oxide (ITO) electrodes produced a stable mixed potential response in the presence of up to 5% of H₂ in air with very low response to CO₂ and water vapor. The sensor also showed desirable characteristics with respect to response time and resistance to aging, and degradation due to thermal cycling.

In this investigation, the development and testing of an electrochemical hydrogen (H₂) sensor prototype based on ITO/yttria-stabilized zirconia (YSZ)/platinum (Pt) configuration is detailed. The device fabricated using commercial ceramic sensor manufacturing methods on an alumina substrate with an integrated Pt resistance heater to achieve precise control of operating temperature while minimizing heterogeneous catalysis and loss of hydrogen sensitivity. Targeting fuel cell vehicle infrastructure, the safety sensor was subjected to interference studies, temperature cycling, operating temperature variations, and long-term testing now exceeding over 6,000 hrs for some sensor configurations. In FY 2011, FY 2012, and FY 2013 the mixed potential electrochemical technology was independently validated at the hydrogen safety sensor-testing lab at the National Renewable Energy Laboratory (NREL) in three separate rounds of testing. In each round, two packaged pre-commercial prototypes were tested against a standard testing protocol including the effects changes in ambient temperature, pressure, humidity, and oxygen partial pressure and sensor resistance to cross-interferences such as CO, CO₂, CH₄, and NH₃. In general, NREL testing showed a fast response to H₂ with exceptional low-level sensitivity and high signal-to-noise, very little deviation in sensor response to changes in ambient conditions such as humidity and barometric pressure, and minimal response to some common interference gases. However, potential weaknesses were found in the first two rounds of testing such as changes in sensor calibration with ambient temperature changes and complete sensor failure under the most harsh operating environment tested (anaerobic conditions, which

would only happen under extremely unusual conditions) were identified. These last NREL-identified performance issues were ameliorated in FY 2013 and FY 2014. In FY 2013, a more chemically robust electrode was tested in a wide range of oxygen partial pressures (rich conditions to 100% O₂). The La_{0.8}Sr_{0.2}CrO₃ perovskite electrode will be incorporated into new ESL ElectroScience, Inc. devices and tested within work planned for FY 2015.

FY 2014 work focused primarily on the design, development, and testing of hardware required for field testing deployment at hydrogen refueling stations in California. In addition to technical work, pursuit of an indemnity agreement, commercial partner outreach, and planning for adherence to codes and standards in designing the prototype units were accomplished. In order to facilitate deployment at on site locations, a wireless means of transmitting sensor data was adopted. This extra step will represent a very small addition to package cost since low-cost commercial-off-the-shelf wireless systems are readily available. Of course, going wireless makes it unnecessary to run lengths of wiring through runs of explosion proof conduits, which is a very large cost increase for station operators. A new circuit board design was prepared by Custom Sensor Solutions, Inc. that combined the high impedance buffer circuit and sensor heater control board into one streamlined unit. The first of the new boards were delivered in May 2014 and testing and circuit revisions/optimization continued through June. At the end of June, all of the components were integrated into a commercially sourced, NEMA Class 8 enclosure and systems testing began in July in the laboratory (wireless portion excluded pending approval by DOE/National Nuclear Security Administration [NNSA]/LANL Security and Safeguards procedures).

A dedicated LabVIEW-based software program was developed by a certified LabVIEW developer (Agile Engineering with software/wireless communications testing performed by Zircoa Inc.). This executable code was designed to accommodate up to three independent, wireless hydrogen sensors at each deployment location. Given the exposure to outdoor environment at the primary California testing site, a ruggedized industrial computer with solid-state storage was selected and daily performance of the field trials unit will be carried out using remote access communication via the Internet.

The salient features of the hydrogen sensor prototype developed by LANL and LLNL are (a) low power consumption; (b) compactness to fit into critical areas for some applications; (c) simple operation; (d) fast response; (e) a direct voltage read-out circumventing the need for complicated signal processing; (f) a low-cost sensor platform; (g) excellent stability and reproducibility all of which are conducive to commercialization using common ceramic manufacturing methods; (h) low cost; and (i) technology readily lends itself to mass manufacturing protocols

RESULTS

(a) Layout and design, prototype testing of field trials electronics: In FY 2013, the principal goal for the third round of NREL testing was to test performance of the LANL/LLNL hydrogen safety sensor prototype with active temperature feedback and control. The variation in sensor output voltage with temperature is well known since the response of mixed potential sensors is governed by electrode kinetics and the electrochemical reactions are a strong function of temperature. The small changes in the sensor Pt heater resistance was used to provide feedback to a heater control circuit designed and constructed for this project by Custom Sensor Solutions (Tucson, AZ). Figure 1 shows an actual photograph of the electronic control for field trials operation. This new circuit board combines the constant resistance power supply with the high-impedance buffer that protects the sensor from stray currents from data acquisition boards and permits control of baseline offset and amplifier gain. This circuit uses a voltage output from a simple analog bridge to add/subtract to the heater voltage using the resistance from the sensor's Pt resistive heater as the control point. It is a very simple circuit and mode of operation that effectively maintained sensor temperature despite large changes in ambient temperature (over 90°C range tested in NREL test protocol during Round 3 testing FY 2013) or local changes in sensor element temperature due to heat generated by hydrogen combustion. This will be very important as will be discussed below: the location of the hydrogen refueling stations are in Southern California and the facility locations for sensor deployment are within enclosures exposed to direct

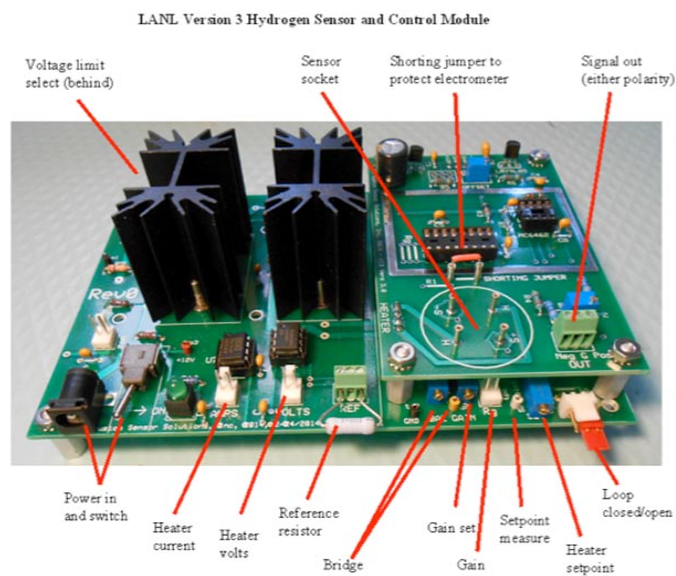

FIGURE 1. Field trials control electronics designed and constructed by Custom Sensor Solutions. This board simplifies the circuitry that maintains constant sensor temperature while adding the high impedance buffer and providing a direct-to-board mounting of the sensor package.

sunlight and internal temperatures can easily vary by 30°C throughout the course of a day in the summer.

(b) Identification of commercial California filling station partner and on-site inspection/evaluation for siting field trials units: In late FY 2013 several potential hydrogen-filling locations were identified in the State of California. LLNL took the lead in preparing a draft indemnity agreement that outlined purpose, explanation of technology, goals, and path forward for commencing with testing and collecting a database of field trials hydrogen sensor units. Contact was made with Dan Poppe of Hydrogen Frontier Inc. (Glendale, CA) and arrangements were made to visit the Burbank filling station facility in April 2014. A survey of the facility and identification of potential sites to locate field trials sensor units was accomplished. Figure 2 shows a collage of photographs and shows areas where there are known hydrogen leaks or potential for hydrogen accumulation. Other important observations were sources of power and location of existing commercial H₂ detectors (optical/thermal/chemical, etc.). FY 2015 will commence with operation of a LANL-built field trial unit inside the dispensing island (left, Figure 2).

(c) Ignition probability experiments (in mixtures up to 20% H₂ in air) performed at LANL using actual sensor and packaging: Concerns raised by reviewers during prior Annual Merit Review briefings and at Safety, Codes and Standards Tech Team presentations about the possibility of the LANL/LLNL mixed potential sensor acting as an

ignition source were addressed this year and as part of the compilation of information for the indemnity agreement draft document. Because the sensor technology is a derivative of the automotive oxygen lambda sensor, the electrolyte is a stabilized zirconium oxide and as such, the temperature of the electrolyte must be raised to at least 400°C for normal operation. Although this temperature is below the autoignition temperature of hydrogen, the preferable temperature set point is 475–500°C and this approaching the autoignition temperature and if, in the event of a circuit failure, cross this threshold. (Protective voltage limits – user selectable – were built into the heater power circuit so this event can be mitigated by proper set-up of the field trials unit before deployment.) A flame arrester was incorporated into the ceramic sensor package and an operating device was tested in H₂/air mixtures up to 20 vol% at LANL. Safety Standard for Hydrogen and Hydrogen Systems 1740.16 was consulted as guidance vis-à-vis specific information regarding flame arrester specifications for hydrogen. Figure 3 illustrates the test apparatus that was built in an outdoor hydrogen facility at LANL. An existing Integrated Work Document was modified to permit working with flammable mixtures of hydrogen and air and these mixtures were introduced into a chamber with a packaged sensor (open-ended stainless steel tube). The power supply output voltage was monitored (tracking heat of combustion effects on sensor element during hydrogen exposure) as well as the temperature fore, aft, and at the mixing junction by three Type K thermocouples. The ignition of the flammable gas could be inferred by observing a spike

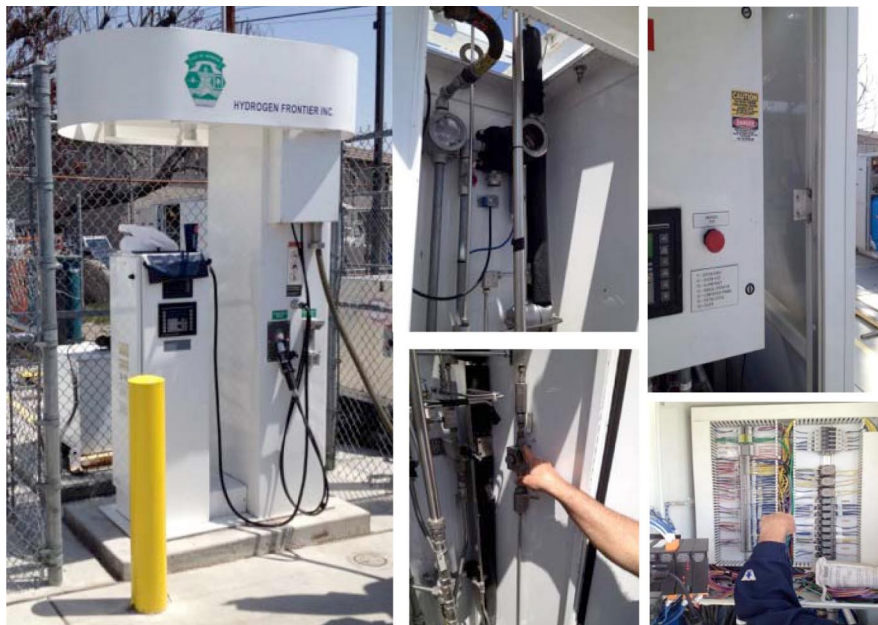
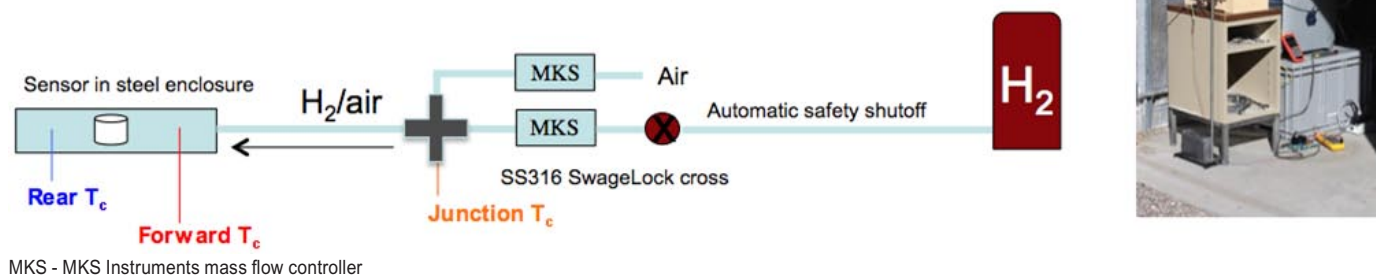

FIGURE 2. Photographs taken on site at the Burbank Hydrogen Frontier location. Although four suitable locations were identified, the location inside the hydrogen dispensing island enclosure (left and top/bottom center) was deemed the most desirable for single sensor unit deployment. Locations for test units to access 24-V direct current power were also identified (lower right).



MKS - MKS Instruments mass flow controller

FIGURE 3. An open outdoor facility at LANL was used to test packaged, working LANL/LLNL H_2 sensors in flammable mixtures of hydrogen and air.

in temperature. The experiments were conducted with, and without the presence of the flame arrester and while the sensor was being overdriven by the applied voltage (sensor glowing orange, well above operating temperature) and at no time was there a deviation in the temperature of the thermocouples signifying ignition of the flammable mixture. The apparatus was tested using a flame and ignition was observed, followed by flame propagation to the final thermocouple location and the automatic safety system terminated hydrogen flow to the experiment.

In the final experiment, the sensor was placed into a standard Plexiglas[®] test chamber and 10 vol% H_2 /air was introduced for 15–20 minutes. The lid was not held in place as was normal procedure so rapid venting and pressure release would be permitted if ignition occurred. No ignition was observed as was expected given the results of the flow experiments conducted earlier. Figure 4 shows a photograph of the static test cell used in this final experiment.

(d) Design of NEMA-8 enclosures and component integration/testing: In the final work conducted in FY 2014, a prototype field trials sensor unit was constructed using commercially sourced NEMA-8 enclosures and hardware. The lack of free space in explosion proof electrical conduits at the Hydrogen Frontier facility in Burbank precluded running new cables to provide power the sensor and electronics, and providing a means to send the sensor signal back to the data acquisition computer. Therefore, an inexpensive commercial wireless system was adopted (Omega Engineering). The field trial unit was constructed that placed the sensor/heater control and the wireless transmitter into a single NEMA-8 enclosure. Provisions were made to power the unit either by 120-V AC or by 24-V DC (as will be the case at the Burbank facility). A schematic of a deployed three-sensor network is also shown in Figure 5. Testing of the field trial unit is underway at LANL the time this report was assembled.

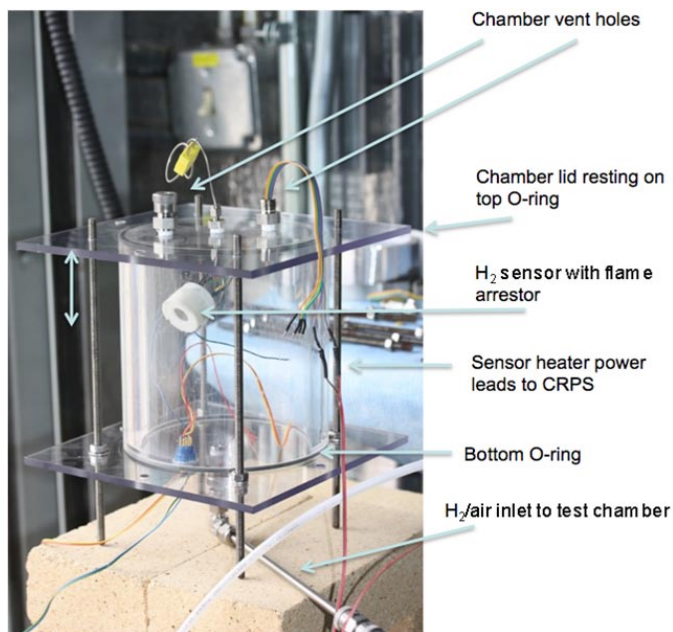

FIGURE 4. 10 vol% H_2 in air was introduced into a sensor test cell with sensor set at normal operating temperature inside the ceramic package that incorporates a flame arrester. No ignition was observed during exposures up to 20 minutes. A Custom Sensor Solutions Constant Resistance Power Supply (CRPS) was used to maintain the sensor element at a normal operating temperature throughout the experiment.

The outdoor location and large temperature swings together with vibration, dust, and wildlife exposure, fires, etc. precluded the use of consumer computer equipment. An Advantech solid-state computer was selected and control software was custom designed by Agile Engineering and Zircoa Inc. Agile developed the software (executable LabVIEW program) and Zircoa tested the software and wireless systems. LANL is presently awaiting permission to test and use the wireless systems and is adhering to DOE/NNSA security requirements.

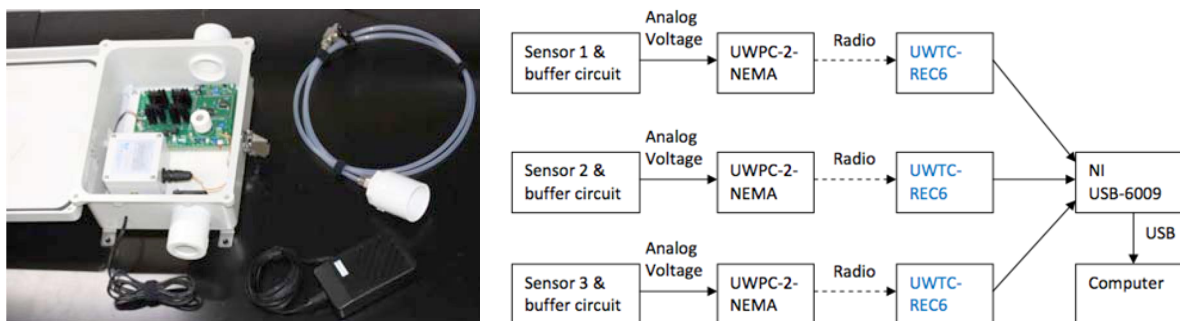

FIGURE 5. (left) Photograph of the first field trials LANL/LLNL hydrogen safety sensor unit and (right) a schematic of operation of a deployed, three-sensor system using a single industrial computer to log sensor voltage and calculated H₂ concentration.

(e) Establish design specifications for improved sensor platform and next generation electrode material from commercial partner ESL ElectroScience:

All hydrogen sensors fabricated for use in this project over the past two years came from substrates prepared by ESL ca. 2011-2012. A new ceramic tape was used for the platform that may permit a very small amount of leakage current between heater circuit and sensor circuit. This leakage current prevents the LANL/LLNL H₂ sensor and impedance buffer circuits from operating at peak performance. A new batch of sensor platforms will be fabricated using higher performance tapes together with an insulating base coat. Moreover, an improved sensor design will be tested that utilizes the working electrode material reported last year the will easily entertain continued sensor operation in anaerobic conditions that NREL tested for in FY 2013. The use of a lanthanum chromite-based electrode will also permit the fabrication of the complete sensor in a single, two-step commercial firing approach that will significantly reduce fabrication costs and labor. Discussions with ESL began in the summer of FY 2014.

CONCLUSIONS

- The FY 2014 milestones were completed this year.
- A viable hydrogen safety sensor technology has been developed on an advanced sensor platform that continues to improve. An advanced hydrogen sensor prototype was fabricated on an alumina substrate with ITO and Pt electrodes and YSZ electrolyte with an integrated Pt heater to achieve precise operating temperature and minimize heterogeneous catalysis.
- New electronic control circuits were designed and fabricated that simplified the analog constant resistance power supply that maintains precise sensor Pt heater resistance (and therefore maintains precise temperature) and combines the high impedance buffer circuit that permits use of inexpensive National Instruments NI-6009 USB-DAQ unit to acquire sensor signal. Impedance buffer was designed to directly accept LANL

sensor packaging to eliminate need for pigtail wires and to reduce noise and improve reliability.

- The prototype field trials system was situated inside a NEMA-8 enclosure guided by Class 1/Div. 2 standards along with wireless transmitter and supporting hardware. A means for one-time calibration was devised and tested.
- A model off-site field test plan for DOE federal laboratories developing project-funded technology, including insurance and indemnity that is required was drafted by LLNL. The experimental verification of intrinsic safety for the technology conducted at LANL was included as an appendix. In these experimental tests, ignition probability experiments in atmospheres up to 20 vol% H₂ in air were tested with naked sensors (no flame arrestor cap). At no time did a LANL/LLNL hydrogen sensor ignite flammable hydrogen mixtures with/without flame arrestor in place and at/well above normal sensor operating temperature in either dynamic static conditions.
- Several testing sites were identified in California. Discussions began in the end of FY 2013 with Dan Poppe at Hydrogen Frontier LLC. LANL research staff visited Hydrogen Frontier in April 2014 and three locations within the Burbank facility were identified as potential locations to site experimental field trials test units. As space within the explosion-proof wiring conduits was largely unavailable, a wireless system of operation was selected. Operational challenges identified include: high heat within cabinets (outdoor facility) and large temperature swings, vibration, insects, spiders, wind, water, potential for brush fires, flooding and nesting birds. Location ruled out the original plan to use a consumer laptop computer for data acquisition. A hardened, industrial computer was selected along with means to remotely interrogate sensor operation on a daily basis.
- In FY 2015, the California South Coast Air Quality Management District has tentatively agreed to co-fund the field test work (Board approval of proposal likely

in September) and two additional sites are the refueling stations at South Coast Headquarters in Diamond Bar and at the new station at California State University, Los Angeles.

- Systems integration and testing were started at LANL in June 2014 with target of August to complete initial testing of the first field trial unit.

FUTURE DIRECTIONS

- Build, test, and optimize design of field trial units (to extent permitted by resources).
- Site sensor unit(s) at Hydrogen Frontier in Burbank California South Coast Air Quality Management District, and potentially one additional location.
- Collate and analyze data from remote location.
- Set up mock field trials unit and experiments (NREL collaboration desired).
- Perform limited field testing.
- Seek out and engage potential partners for sensor testing and technology commercialization.
- Use data from deployed units to improve future field trial units.

COLLABORATION AND COORDINATION WITH COMMERCIAL PARTNERS AND OTHER INSTITUTIONS

- Los Alamos National Laboratory
- Lawrence Livermore National Laboratory
- Custom Sensor Solutions, Inc.
- Hydrogen Frontier, Inc.
- National Renewable Energy Laboratory
- ESL ElectroScience, Inc.
- Agile Engineering/Zircoa, Inc.

FY 2014 PUBLICATIONS AND PRESENTATION

1. P.K. Sekhar, Jie Zhou, Mathew B. Post, Leta Woo, William J. Buttner, William R. Penrose, Rangachary Mukundan, Courtney R. Kreller, Robert S. Glass, Fernando H. Garzon, and Eric L. Brosha, "Independent Testing of Hydrogen Prototype Sensors," *Int. J. of Hydrogen Energy* **39** (2014) 4657-4663.

REFERENCES

1. W.J. Buttner, M.B. Post, R. Burgess, C. Rivkin, *Int. J. Hydrogen Energy*, **36**, 2462 (2011).
2. L. Boon-Brett, J. Bousek, G. Black, P. Moretto, P. Castello, T. Hübert, and U. Banach, Identifying performance gaps in hydrogen safety sensor technology for automotive and stationary applications, *International Journal of Hydrogen Energy*, **35** (2010), 373-384.
3. H.Iwahara, H.Uchida, K.Ogaki and H.Nagato, Nernstian Hydrogen Sensor Using BaCeO₃-Based, Proton-Conducting Ceramics Operative at 200-900⁰ C, *Journal of The Electrochemical Society*, **138** (1991), 295-299.
4. Y. Tan and T.C. Tan, Characteristics and Modeling of a Solid State Hydrogen Sensor, *The Journal of Electrochemical Society*, **141** (1994), 461-466.
5. Z.Samec, F.Opekar, and G.J.E.F. Crijns, Solid-state Hydrogen Sensor Based on a Solid-Polymer Electrolyte, *Electroanalysis*, **7** (1995), 1054-1058.
6. Y-C.Liu, B-J. Hwang, and I.J.Tzeng, Solid-State Amperometric Hydrogen Sensor Using Pt/C/Nafion Composite Electrodes Prepared by a Hot-Pressed Method, *Journal of The Electrochemical Society*, **149** (2002), H173-H178.
7. L.B. Kriksunov, and D.D. Macdonald, Amperometric hydrogen sensor for high-temperature water, *Sensors and Actuators B*, **32** (1996), 57-60.
8. G.Lu, N.Miura, and N.Yamazoe, High-temperature hydrogen sensor based on stabilized zirconia and a metal oxide electrode, *Sensors and Actuators B*, **35-36** (1996), 130-135.
9. L.P. Martin and R.S. Glass, Hydrogen Sensor Based on Ytria-Stabilized Zirconia Electrolyte and Tin-Doped Indium Oxide Electrode, *Journal of The Electrochemical Society*, **152** (2005), H43-H47.
10. R.S. Glass, J. Milliken, K. Howden, R. Sullivan (Eds.), *Sensor Needs and Requirements for Proton-Exchange Membrane Fuel Cell Systems and Direct-Injection Engines*, 2000, pp. 7 – 15. DOE, UCRL-ID-137767.
11. G.Korotcenkov, S.D.Han and J.R.Stetter, Review of Electrochemical Hydrogen Sensors, *Chemical Review*, **109** (2009), 1402-1433.
12. L.P. Martin and R.S. Glass, Electrochemical Sensors for PEMFC Vehicles, presented at The 2004 DOE Hydrogen, Fuel Cells, and Infrastructure Technologies Program Review, Philadelphia, PA (May 27, 2004).
13. NREL/DOE Hydrogen Sensor Workshop, June 8, 2011, Chicago IL. http://www.hydrogen.energy.gov/pdfs/progress11/viii_3_burgess_2011.pdf
14. F.H.Garzon, R.Mukundan, and E.L.Brosha, Solid state mixed potential gas sensors: theory, experiments and challenges, *Solid State Ionics*, **136-137** (2000), 633-638.
15. P.K.Sekhar, E.L.Brosha, R.Mukundan, M.A.Nelson and F.H.Garzon, Application of Commercial Automotive Sensor Manufacturing Methods for NO_x/NH₃ Mixed Potential Sensors for Emission Control, *ECS Transactions*. **19** (2009), 45-49.