

2004 DOE Hydrogen, Fuel Cells &  
Infrastructure Technologies  
Program Review Presentation

*Development of a Thermal and Water  
Management (TWM) System for  
PEM Fuel Cells*

**Chung Liu**

**Honeywell International, Inc.**

**May 26, 2004; Philadelphia, PA**

This presentation does not contain any proprietary or confidential information.

# Project Objectives

## To assist DoE in developing a humidification and cooling system for PEM Fuel Cells in transportation applications

- To focus on cathode humidification for a 50 kW FC power system
- To study pressurized TWM system performance
- To analyze steady-state automotive operation conditions for comparison of concept schematics
- To establish TWM system / component specifications
- To demonstrate the performance of a breadboard TWM system with research hardware

# Thermal and Water Management System

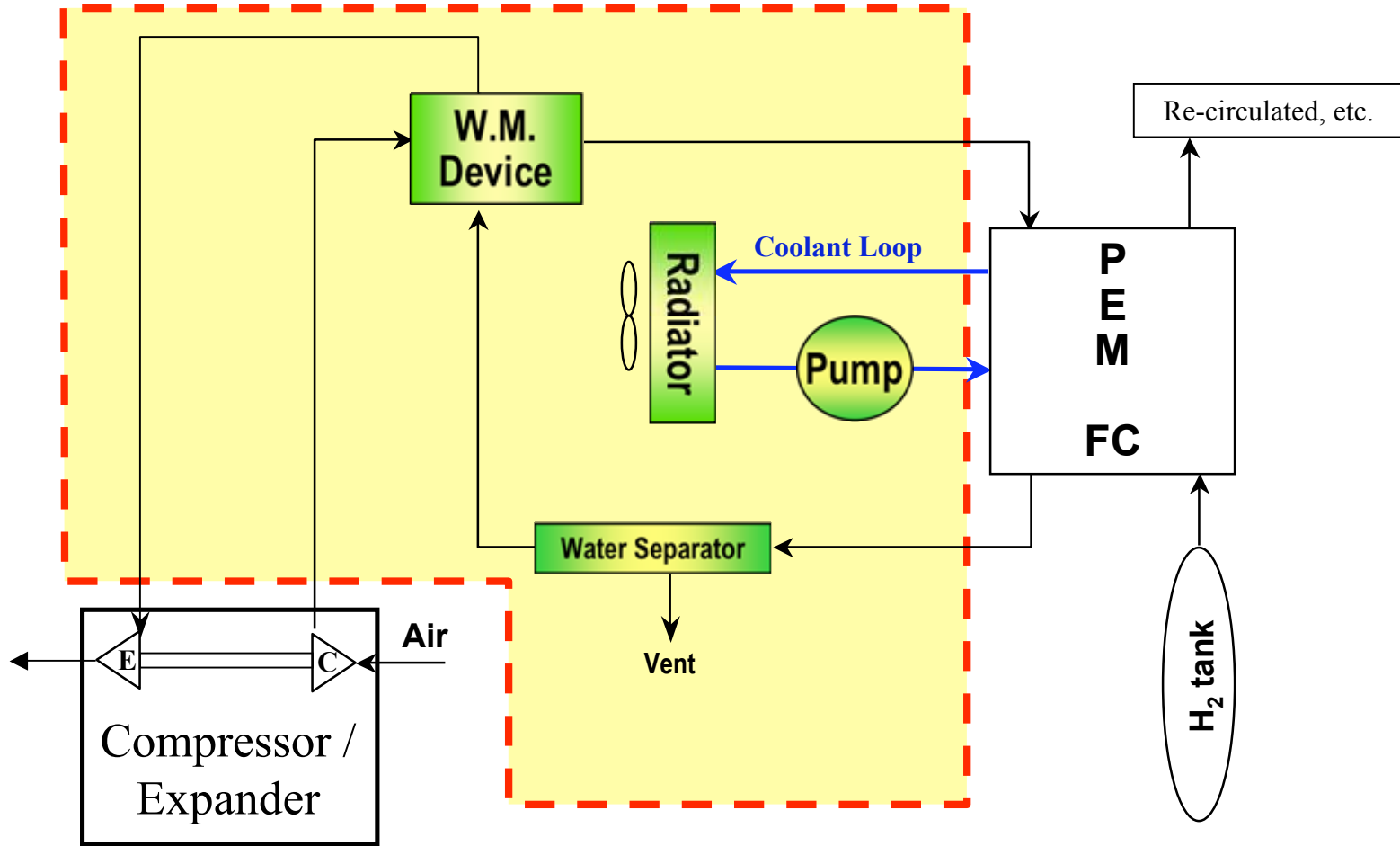

# Budget

<b>FY</b>	<b>\$Total</b>	<b>\$DOE Share</b>	<b>\$Honeywell Share</b>
<b>2004</b>	\$1.23M	\$982K	\$248K
<b>2005</b>	\$1.87M	\$1.5M	\$370K
<b>2006</b>	\$1.00M	\$768K	\$232K
<b>Total</b>	<b>\$4.1M</b>	<b>\$3.25M</b>	<b>\$850K</b>

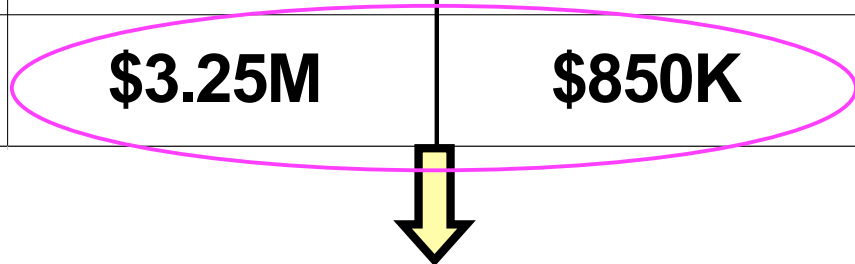

**DoE: 80%**      **HON: 20%**

# Technical Barriers and Targets

- **Technical Barriers:**

HFCIT Program Multi-Year Program Plan

- C. Thermal Management

(Transportation system)

- R. Thermal and Water Management

(Component)

- Capacity to reject low temperature FC stack waste heat
      - Utilize Honeywell core technology of aerospace heat exchangers
    - Water balance (humidification & exhaust water recovery)
      - Evaluate different water management concepts and devices

- **Current Development Priority**

- Size: 5 (most critical)
  - Reliability: 4
  - Cost: 3
  - Power consumption: 2
  - Weight : 1

Targets to be established based on DoE fuel cell power system requirement

# Approach

- **Analytical system simulation**
  - Compare 4 different schematics using
    - (1) adsorbent wheel,
    - (2) membrane humidifier,
    - (3) porous plate, and
    - (4) cathode recycle respectively
- **Water management development**
  - Balance water vapor and heat transport
  - Avoid (or minimize) H<sub>2</sub>O phase change for air humidification
- **Thermal management component**
  - Utilize aerospace designs and automotive manufacturing processes
  - Evaluate other advanced heat exchanger technologies
- **System integration and demonstration**
  - Demonstration tests with fuel cell simulator

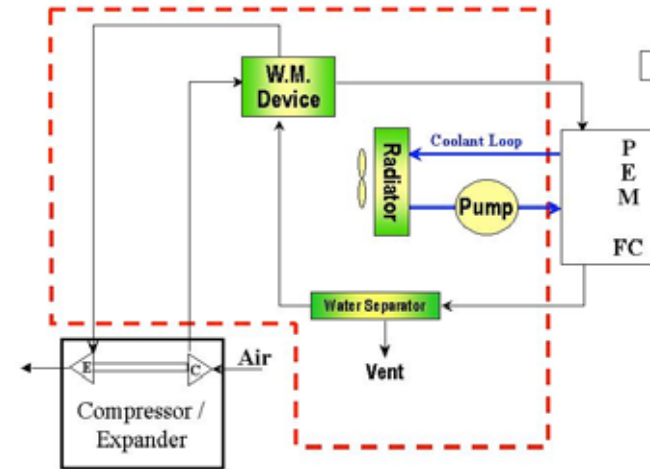

## Facility Related (Honeywell Safety Standard)

---

- The Honeywell Torrance site utilizes a variety of safety techniques in the design of equipment and analysis of potential hazards such as Hazard & Operability Study (HAZOP), FMEA and What If analysis.
- Hazardous Materials, Processes and Operation practice (Form 3134) applies to the use of hazardous materials at Torrance. The New Chemical Approval Request Form is used to assure a knowledgeable Honeywell Safety & Environment person reviews each new chemical.
- All Torrance personnel receive Cal-OSHA regulatory compliance training each year. Additional specialized safety training is also given to certain technicians or crafts.

# Project Timeline

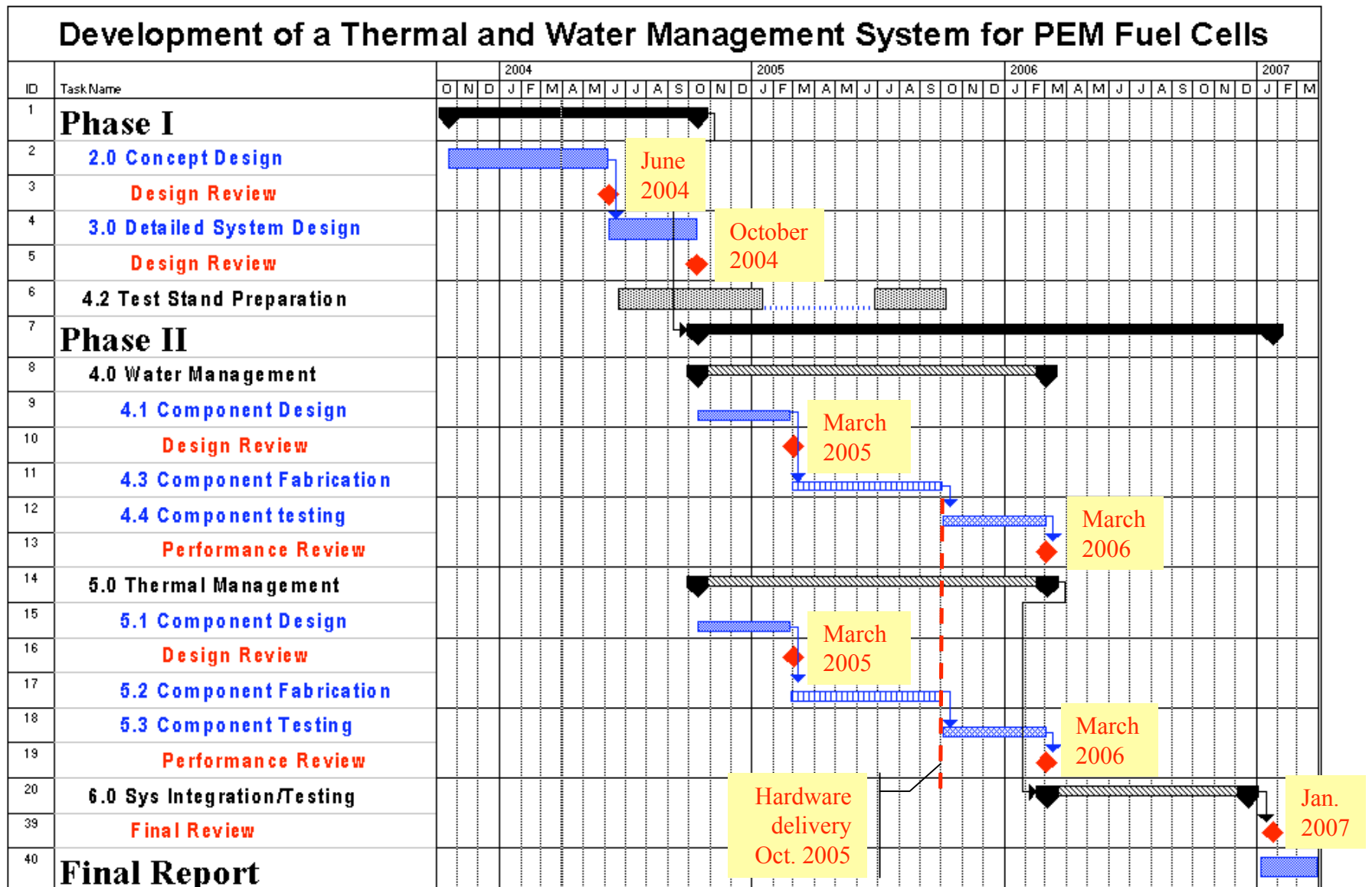



# Technical Accomplishments / Progress

## Next 6 slides:

- FC and compressor interfaces
- Concept analysis
  - adsorbent wheel
  - membrane humidifier
  - porous metal foam humidifier
  - cathode recycle compressor

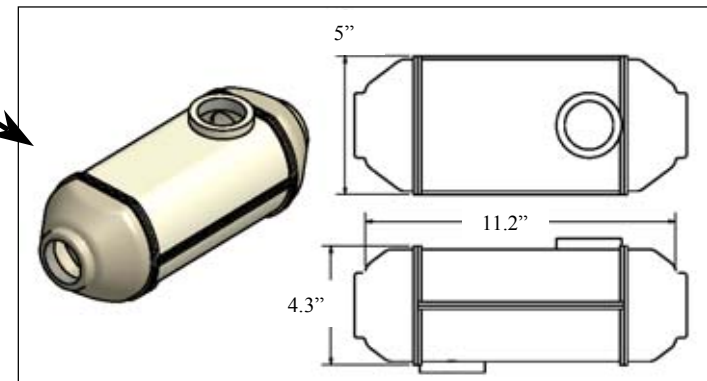
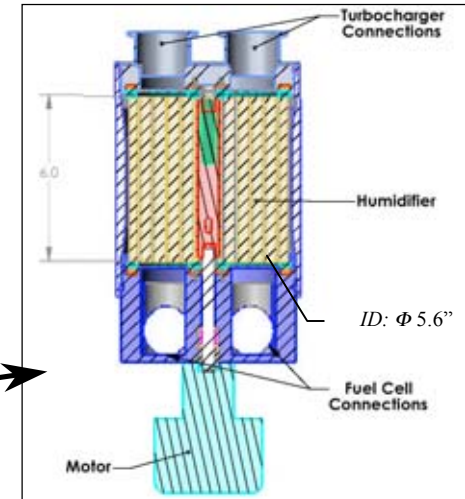

- Radiator thermal performance trade studies

# Technical Accomplishments / Progress

- **Established Fuel Cell interface guidelines**

- Peak power waste heat: 65 kW at 80 °C
- Cathode humidification: 50% to 90% relative humidity
- Oxygen utilization: 50% (stoichiometric ratio 2)

(Received fuel cell stack simulation data from ANL)

- **Obtained air compressor interface requirements**

- Compressed air pressure: 2.5 atm at maximum power
- Compressed air temperature:

- Max. 170 °C at amb. 50 °C / 100% power (may need a pre-cooler)
- Min. -5 °C at amb. -20 °C / 10% power (a potential solution: air re-circulation at compressor stage)

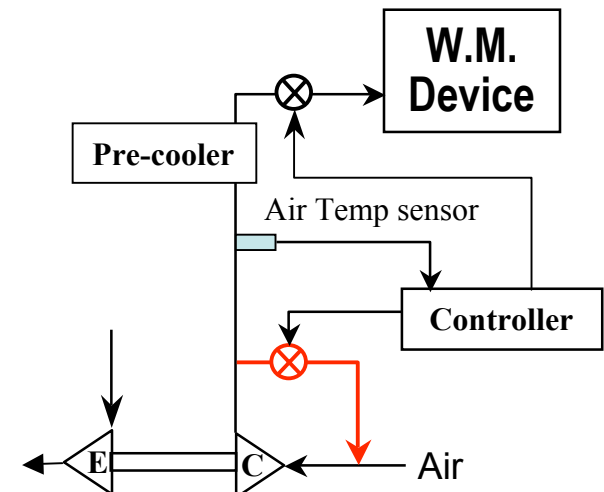

# Technical Accomplishments / Progress

- **Adsorbent Wheel**

- Sub-scale unit performance testing completed
  - 100% FC power
  - 50% FC Power
  - 25% FC power
- System modeling and sizing in progress

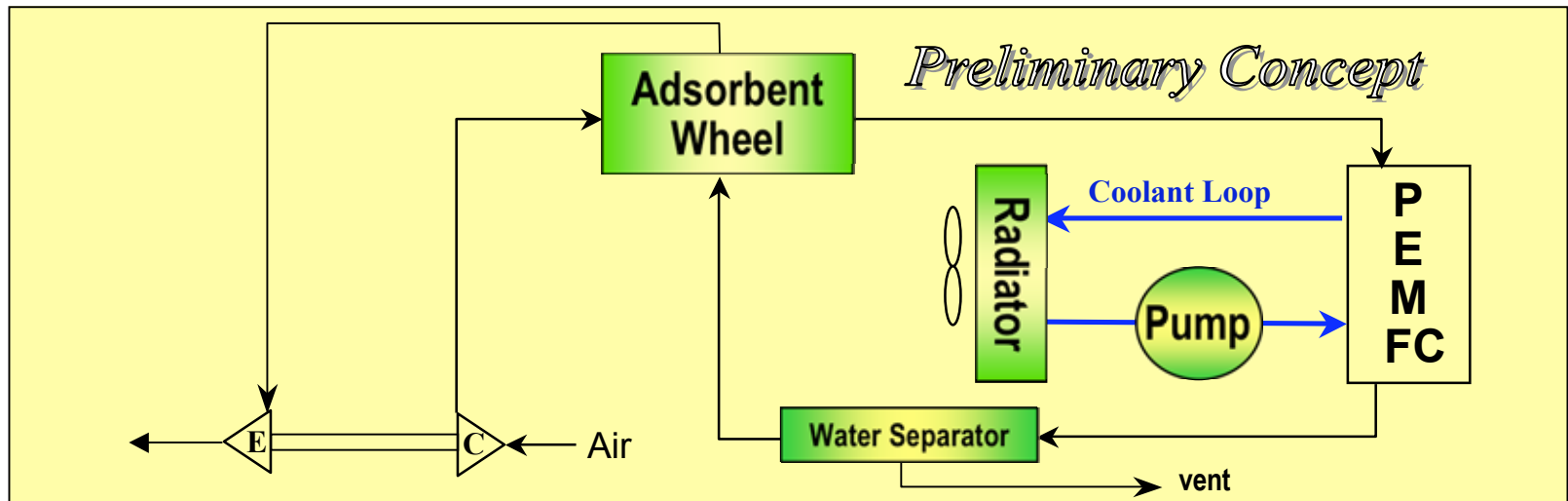
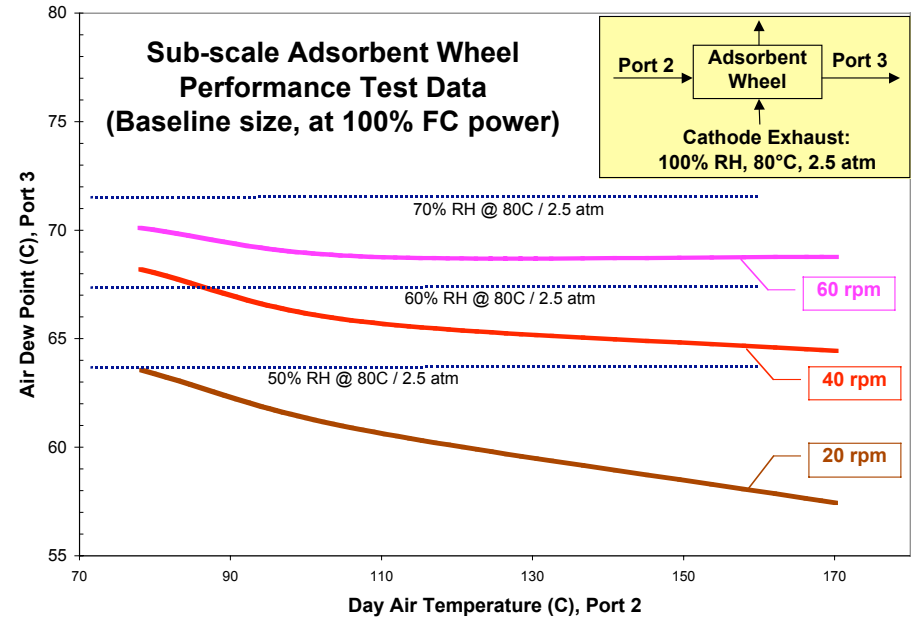

# Technical Accomplishments / Progress

- **Membrane humidifier**
  - Sub-scale unit performance testing completed
    - 100% FC power →
    - 25% FC power
  - System modeling and sizing in progress

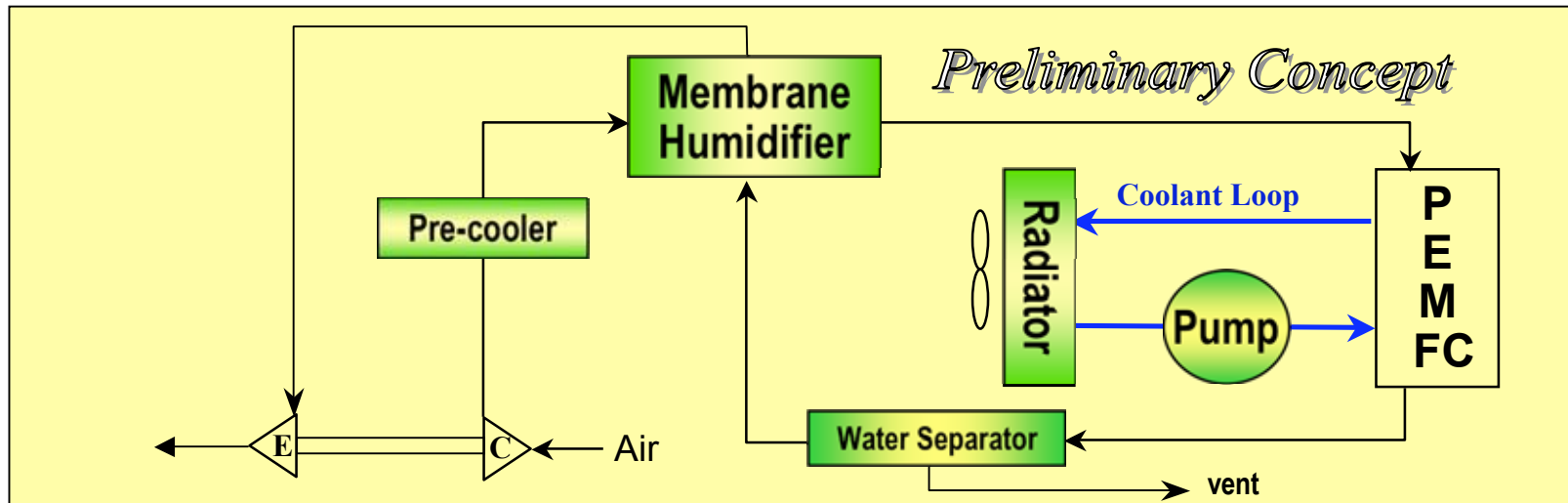
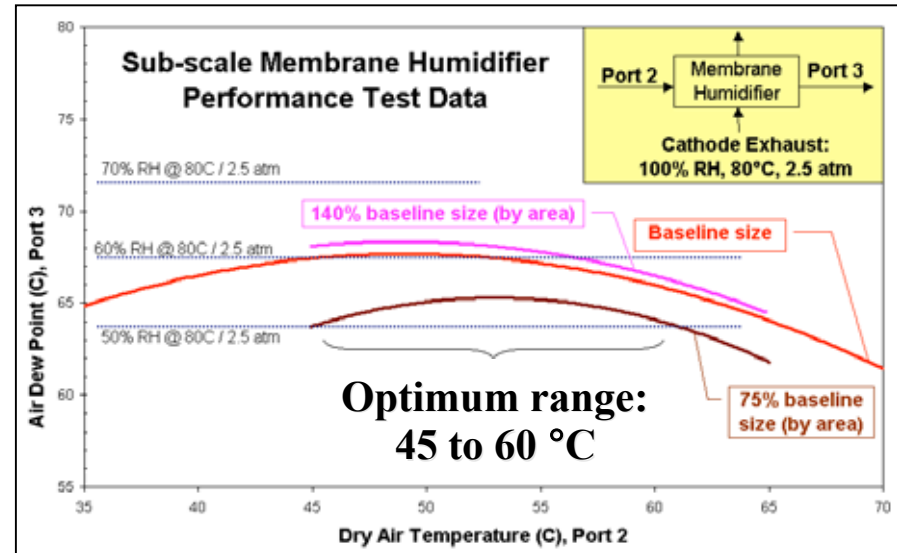

# Technical Accomplishments / Progress

- **Porous Metal Foam Humidifier**

- Evaluation tasks in progress
  - Designed and fabricated samples for material property tests
  - Tested material permeability and bubble pressure
  - Developing input/output performance model for device sizing
  - Establishing preliminary unit size with vendor
- System modeling and sizing in progress

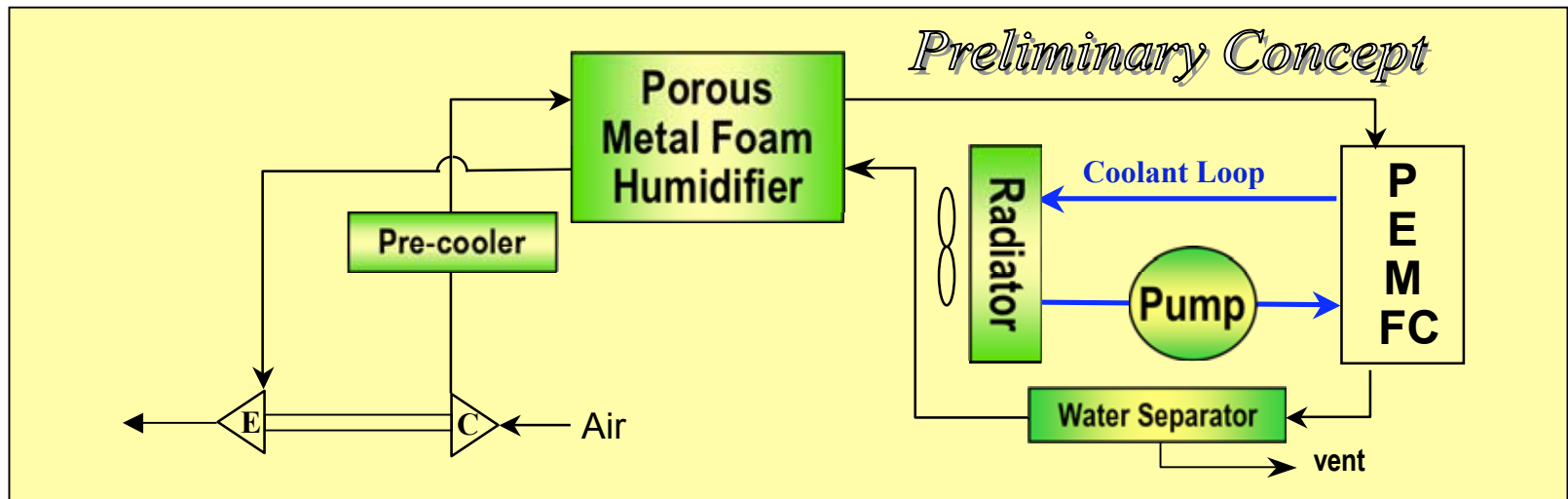

# Technical Accomplishments / Progress

- **Cathode recycle**

- Air humidification: cathode inlet 60% RH condition can be reached with water spray (system complexity increases)
- Recycle fan and recycle compressor are under evaluation for power consumption comparison

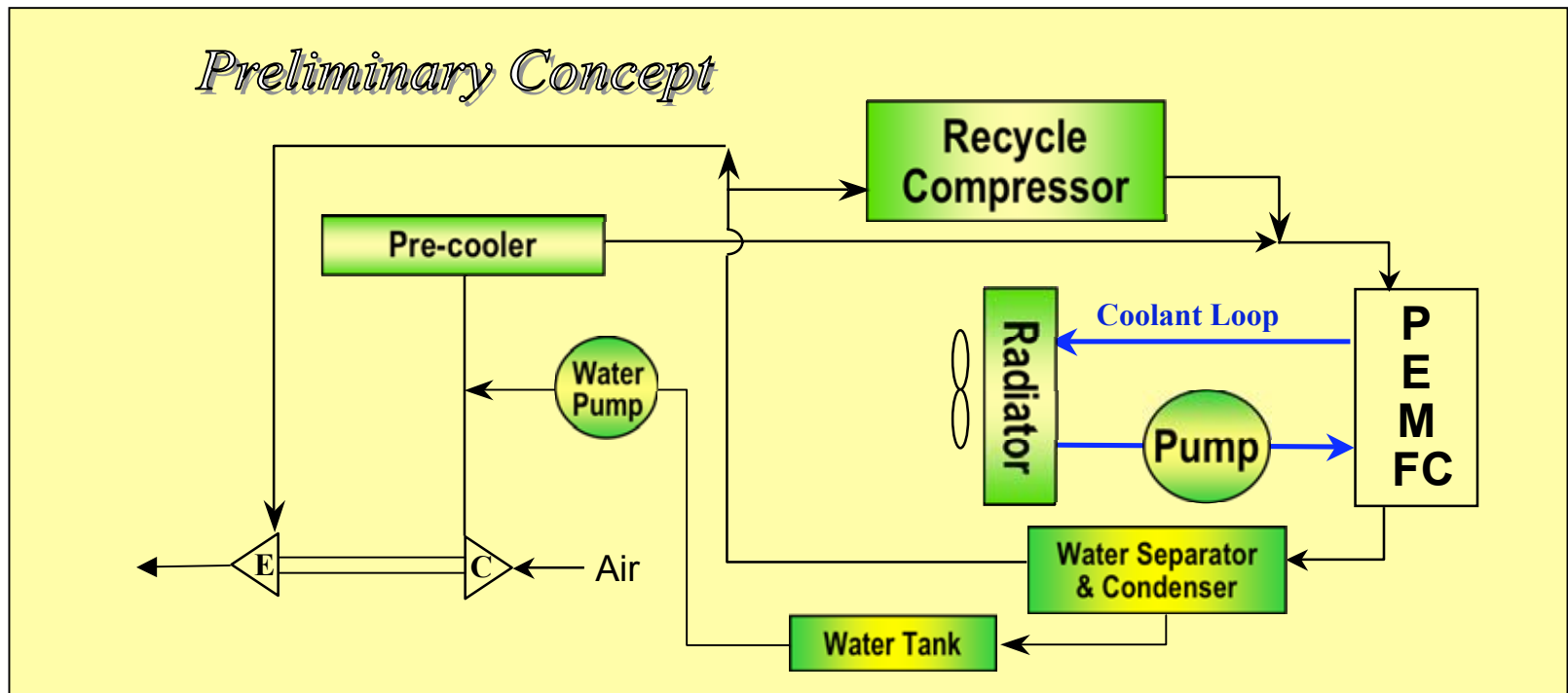

# Technical Accomplishments / Progress

- **Radiator thermal performance trade study**
  - Evaluating 3 options
    - Conventional “automotive” type tube-fin design,
    - Conventional “aerospace” type plate-fin design, and
    - Advanced microchannel type plate-fin design
  - Preliminary volume comparison with 65 kW heat load at 80 °C
    - Conventional “automotive”: 100% - baseline volume
    - Conventional “aerospace”: 75%
    - Advanced microchannel: 50%
  - Additional design trade studies in progress
    - Balancing power consumption, pressure drops, etc.
  - Off-the-shelf automotive designs cannot meet expectations
  - Conventional aerospace & advanced microchannel designs need
    - Suitable air side contamination control and
    - Development for low cost and mass production

# Interactions and Collaborations

- **Argonne National Laboratory**
  - Romesh Kumar, Rajesh Ahluwalia: GCTool program
    - Established interface between the TWM system and PEM fuel cell stack
    - Mutual assistance in adsorbent wheel test / simulation data
- **Honeywell Turbo-compressor project**
  - Established interface between the TWM system and high pressure air management system
- **Fuel Cell Power System / Automotive OEMs**
  - Obtain/seek inputs from OEMs



# Future Work

- **Remainder of FY 2004:**
  - Two design reviews:
    - Down-select the “optimum” TWM system from 4 different concepts
    - Establish TWM system and component specifications
  - Kickoff component designs
  - Start full scale “humidifier” component test bench setup
- **FY 2005:**
  - Complete component designs and procure research hardware
  - Start component testing
- **FY 2006:**
  - Complete component testing
  - Demonstrate a breadboard TWM system performance