

2005 DOE Hydrogen Program Sensor Development DOE Agreement DE-FC36-02AL67615

**Honeywell International
Sensing and Controls
Richard Gehman**

**Principal Design Engineer
May 2005**

This presentation does not contain any proprietary or confidential information

**Project ID #
FC-31**

A 38-month research and development program leading to the creation of physical sensors suitable for monitoring and controlling a polymer electrolyte membrane (PEM) fuel cell-based power plant, including the fuel reformer, fuel cell stack, and thermal management system.

Task 1 – Sensor Requirements – October 2003 to September 2003 (Completed)

Define the requirements of the physical sensors. Preliminary sensor requirements will be evaluated against the requirements created from the customer interviews. A broad market survey will validate the requirements and provide the inputs to the design task.

Task 2 – Sensor Development – October 2003 to October 2004 (Completed)

This task will be an initial development of the Physical Sensors to demonstrate their ability to meet the necessary requirements in a laboratory environment. Several subtasks identified to meet this objective.

Task 3 – Prototype Sensor Build and Test – November 2004 to June 2005 (In Process)

Sensors shall be manufactured into prototypes suitable for third-party fuel cell system testing and evaluation. This includes design and fabrication necessary to meet the requirements of Task 1. Review the necessity for new sensor development versus off-the-shelf sensors or whether the sensing function is still required.

Task 4 – Field Testing – July 2005 to October 2005

It is Honeywell's position that the proposed sensor will gain technical and/or cost advantage by combining the functionality into an overall system architecture and testing them in their intended fuel cell system environment. The purpose of this task is to test and demonstrate the sensors on operating fuel cells and reformers at third-party facilities.

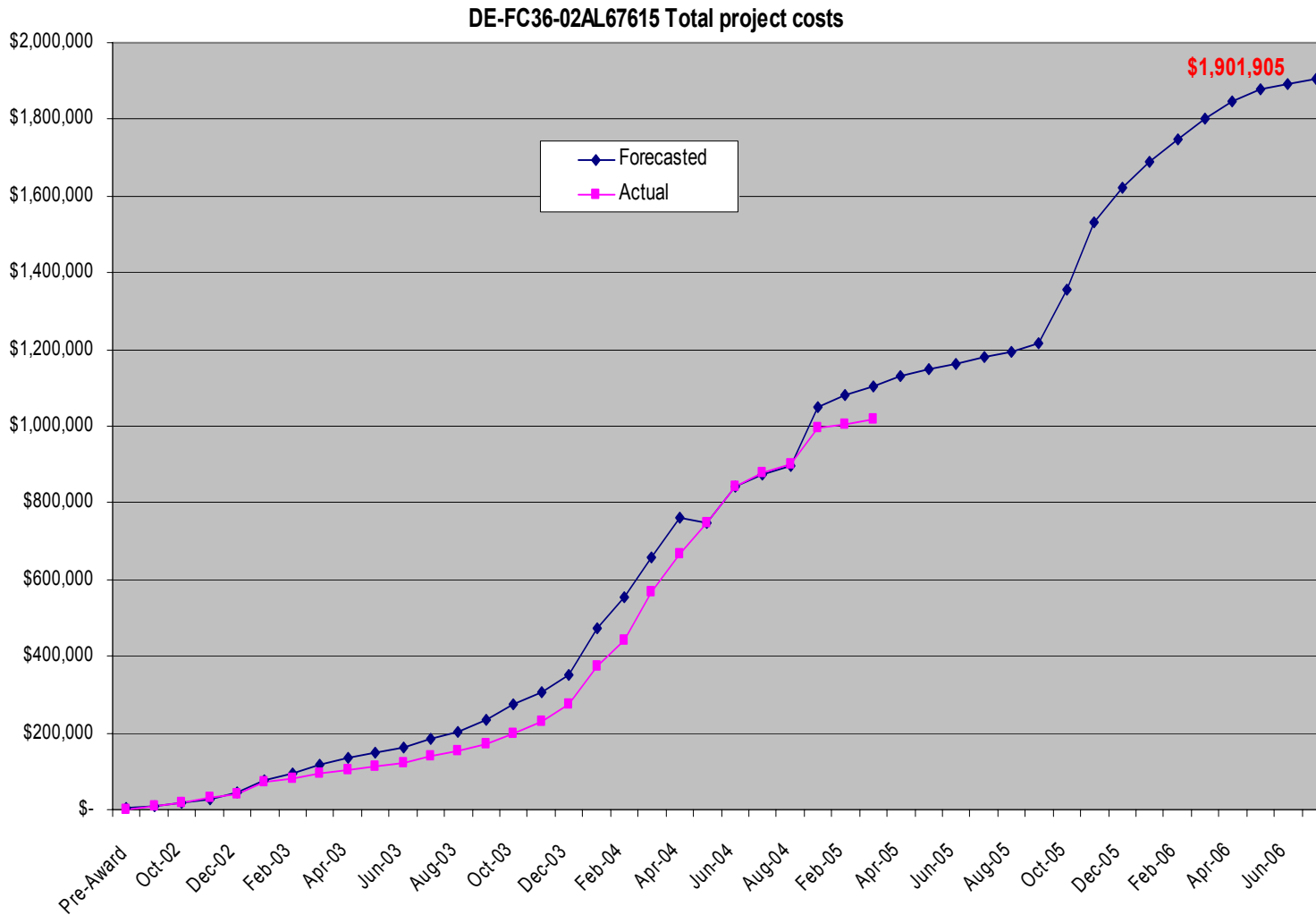

DOE Technical Plan 6/3/03

Honeywell 4/22/05

Humidity

| | | |
|-------------------|-----------|---------------------------------|
| Rh Range | 20 – 100% | 0 to 100% |
| Temperature Range | 30 – 110C | -40 to 90C |
| Accuracy | 1% | 0to80% Rh-4% / 80to100%Rh-2% |

AirFlow

| | | |
|------------|----------------|---|
| Flow Range | 30 to 300 SLPM | Project terminated, Airflow Sensing not needed |
|------------|----------------|---|

Pressure

| | | |
|-------------------|----------------------------------|--------------------|
| Pressure Range | 0 to 1 psi Diff/0 to 10 psi Diff | Project terminated |
| Temperature Range | 30 to 100C | No uniqueness |
| Response Time | <1 second | |
| Accuracy | 1% FS | |

Temperature

| | | |
|-------------------|-------------|--------------------|
| Temperature Range | -40 to 150C | Project Terminated |
| Accuracy | 1.5% | No uniqueness |

General Barriers

- Robust to high humidity and high temperature
- Exposure to DI and Hydrogen media
- Automotive grade
- Cost
- Overall package size
- Overall package weight

Technical Barriers

- *Recovery from a condensing environment
- *Accuracy at high temp and high humidity w/ minimal drift

Targets

- 90C, 100% Rh (environment)
- 0 to 80% Rh – 4% / 80 to 100% Rh – 2%
- 30 second recovery time to 62.3% of Actual

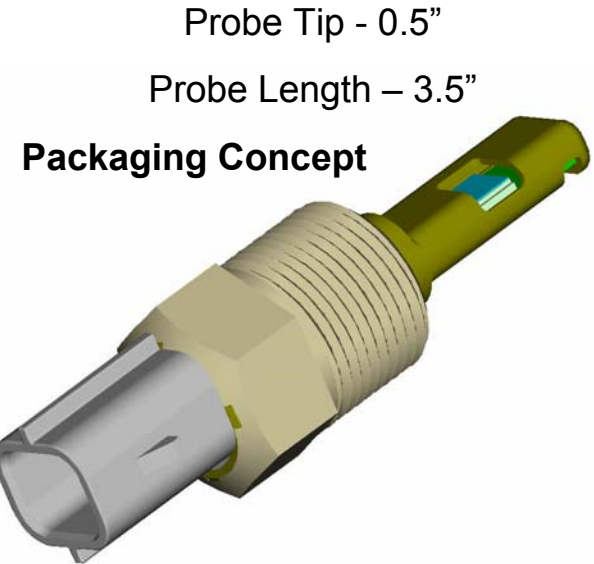

Concurrent research: Identify key process and material parameters for polymer humidity sensing elements combined with heaters.

Look at the fuel cell system and establish the requirements for the RH sensor. Deploy existing technologies and develop packaging strategies to minimize sensor cost. Prototype sensors designed, fabricated, and will be tested in third party fuel cell systems.

Fuel Cell manufacturers now use Instrument-grade sensors to accommodate sensing requirements. Due to cost, size, and weight, instrument-grade sensors do not provide a long term sensing solution for Fuel Cell applications.

Humidity Sensor

Capacitive humidity sensor chip on ceramic with an Application Specific Integrated Circuit (ASIC). The technology is packaged in a heated chamber with a micro-filter and controlled to shift the Dew Point. The sensor assembly is overpackaged in an automotive grade housing. The ASIC is not exposed to the wet hydrogen environment

Humidity:

- Micro-filter performance testing in a condensing environment and heated sensor has been completed
- Condensation tests, with heated Alpha 3 sensing technology, completed
- Selection of ASIC completed ZMD 31050
- Environmental and stability testing completed with Alpha 3 configuration and Ultra H humidity sense die
- Follow-on Research for improved stability Rh sensing film material initiated, Honeywell Laboratories
- Testing has confirmed the Modeling that temperatures throughout the heated package can be maintained and stable in the Alpha 3 and Beta configurations
- Alpha 3 and Beta configurations pass gross H2 leakage tests
- Response time on Alpha 3 sample was 6 sec, 1 sec short of goals

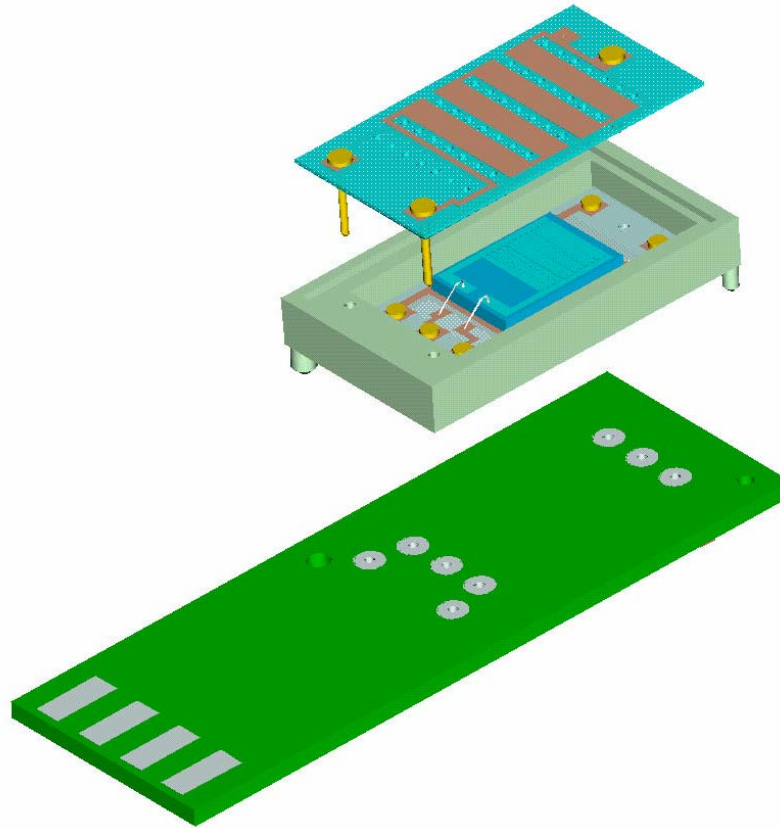

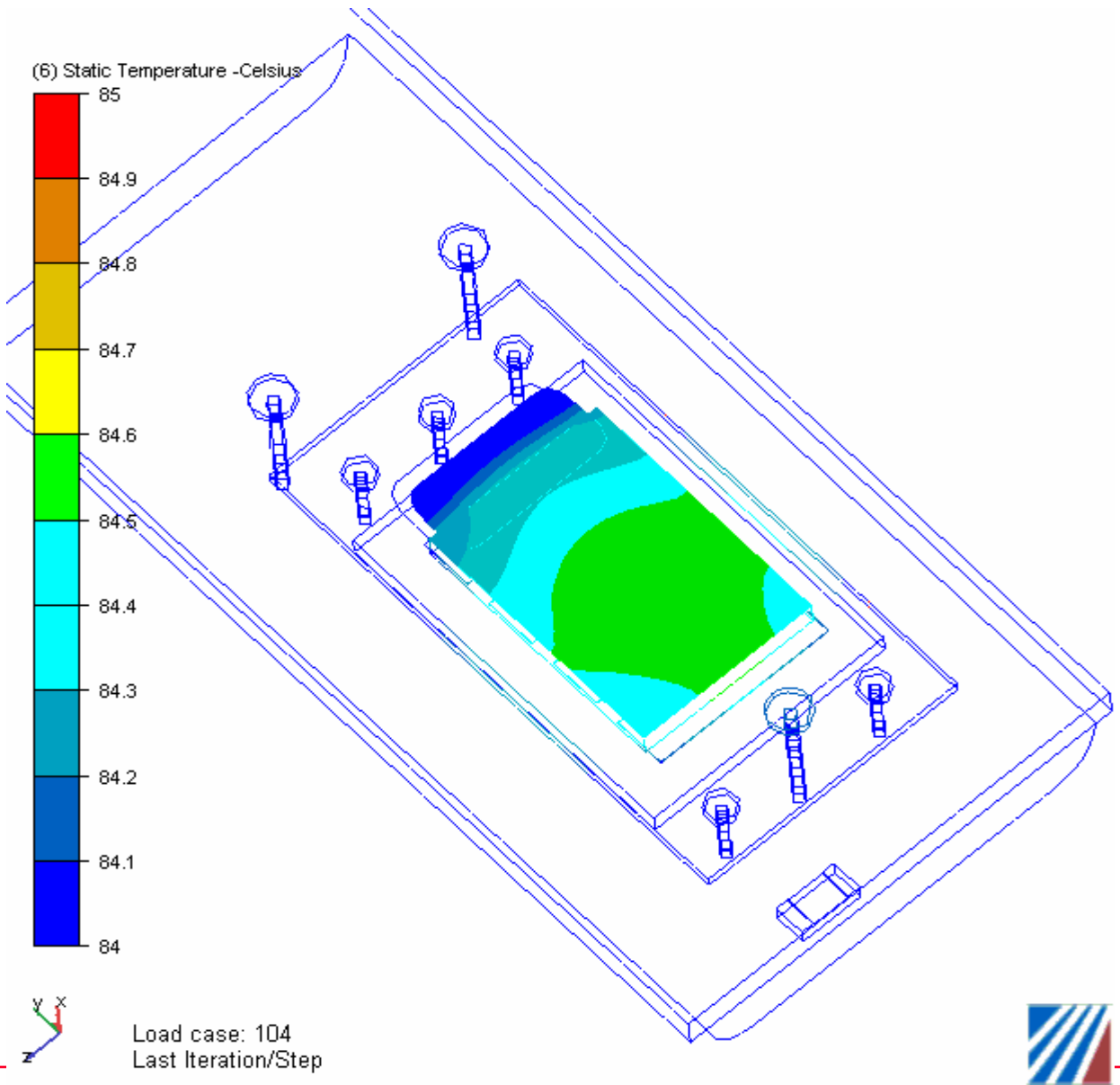

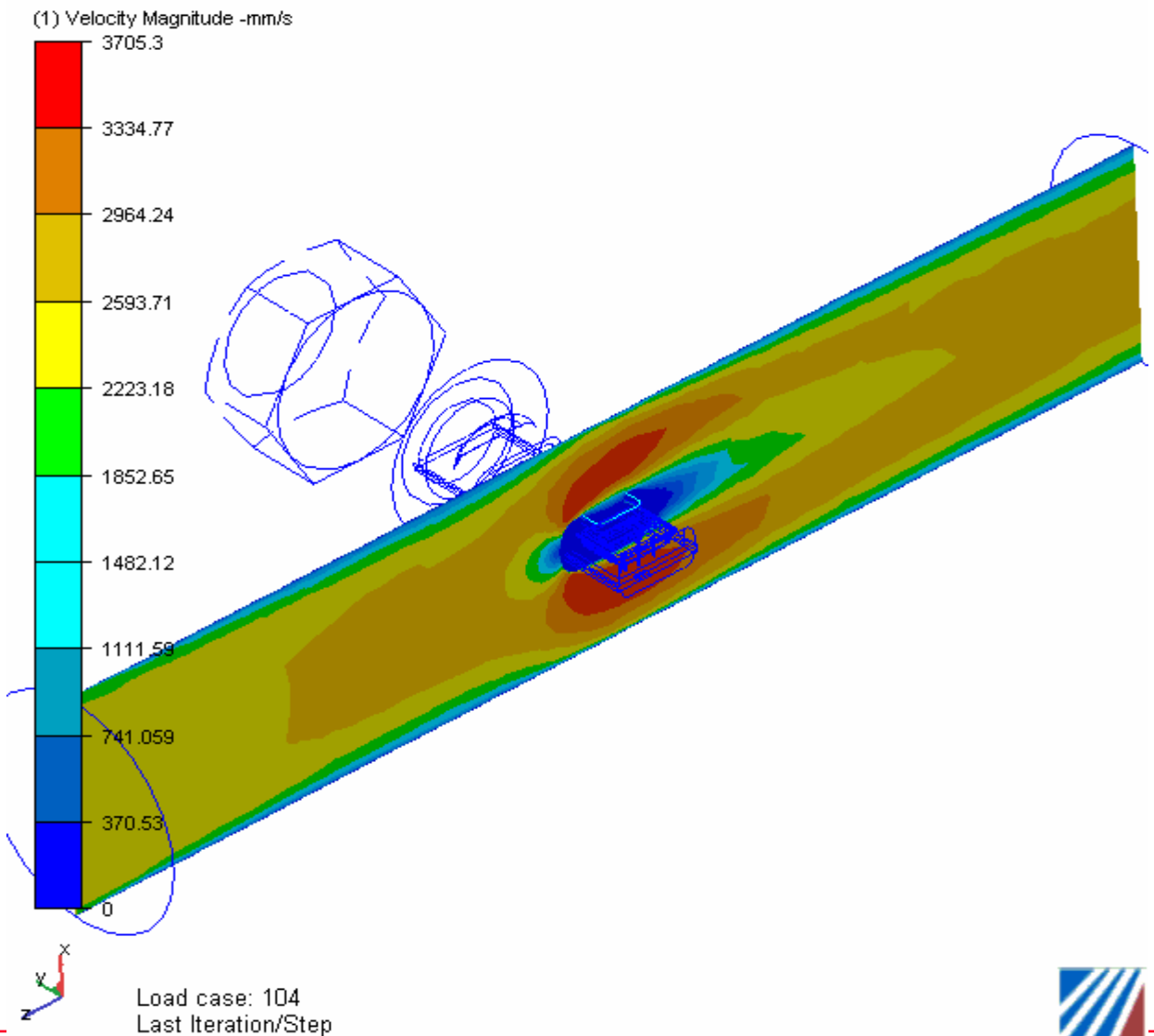

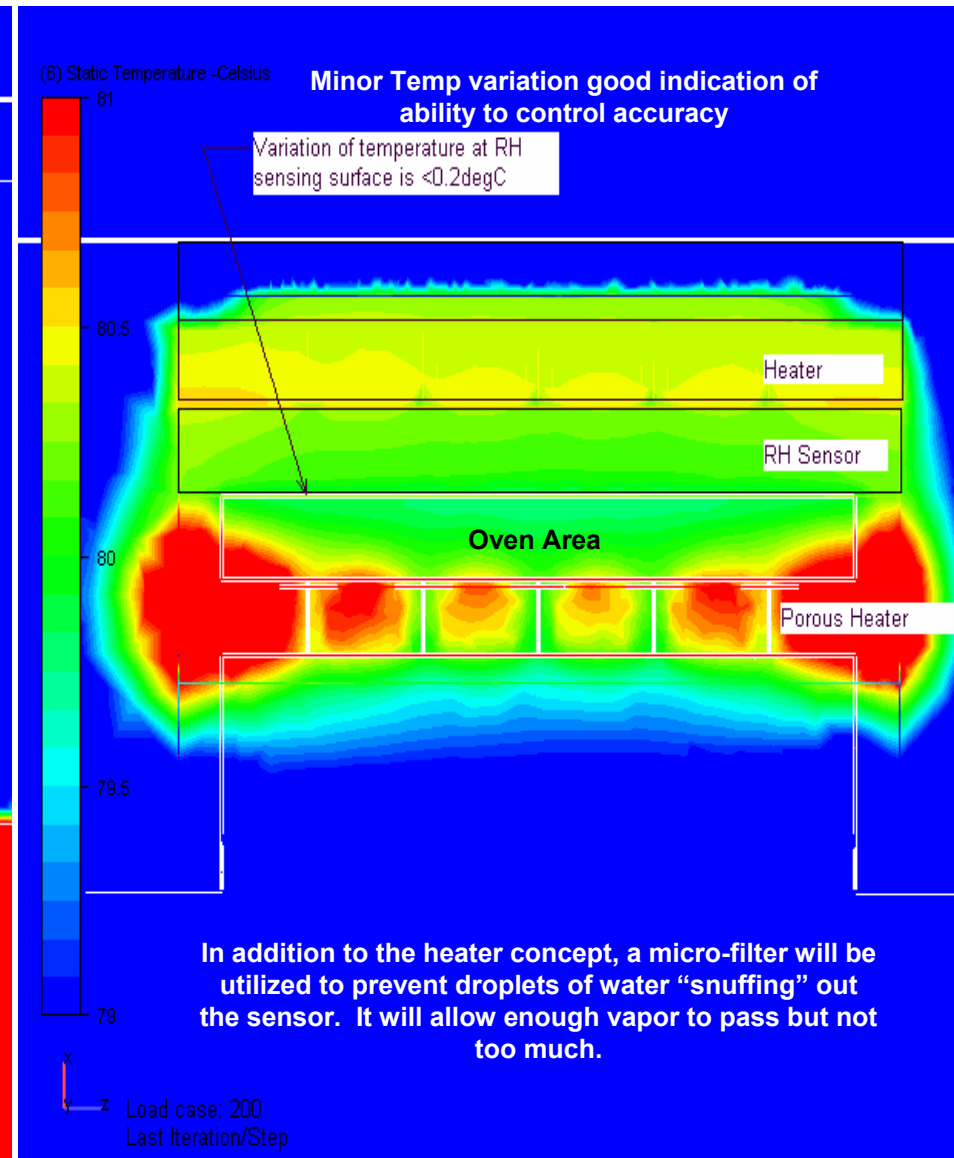
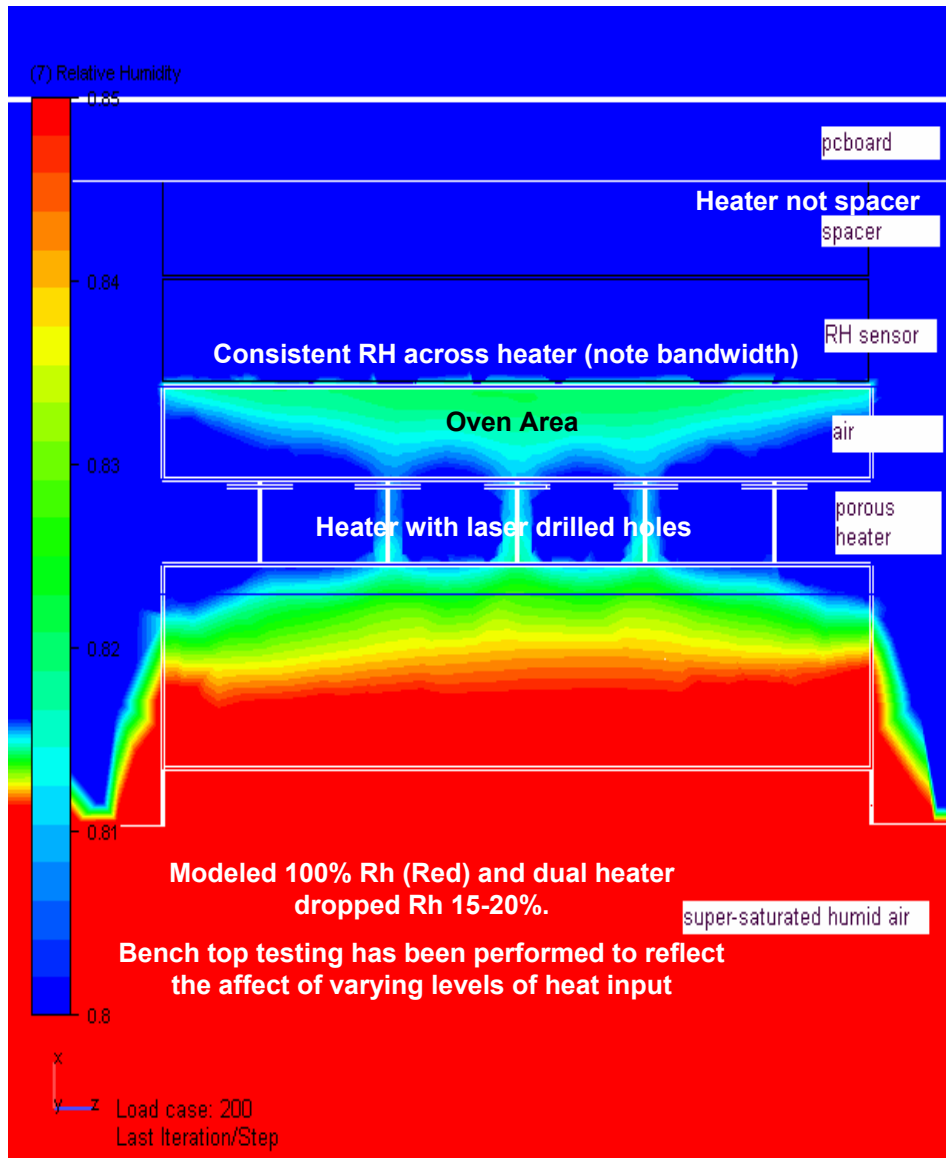

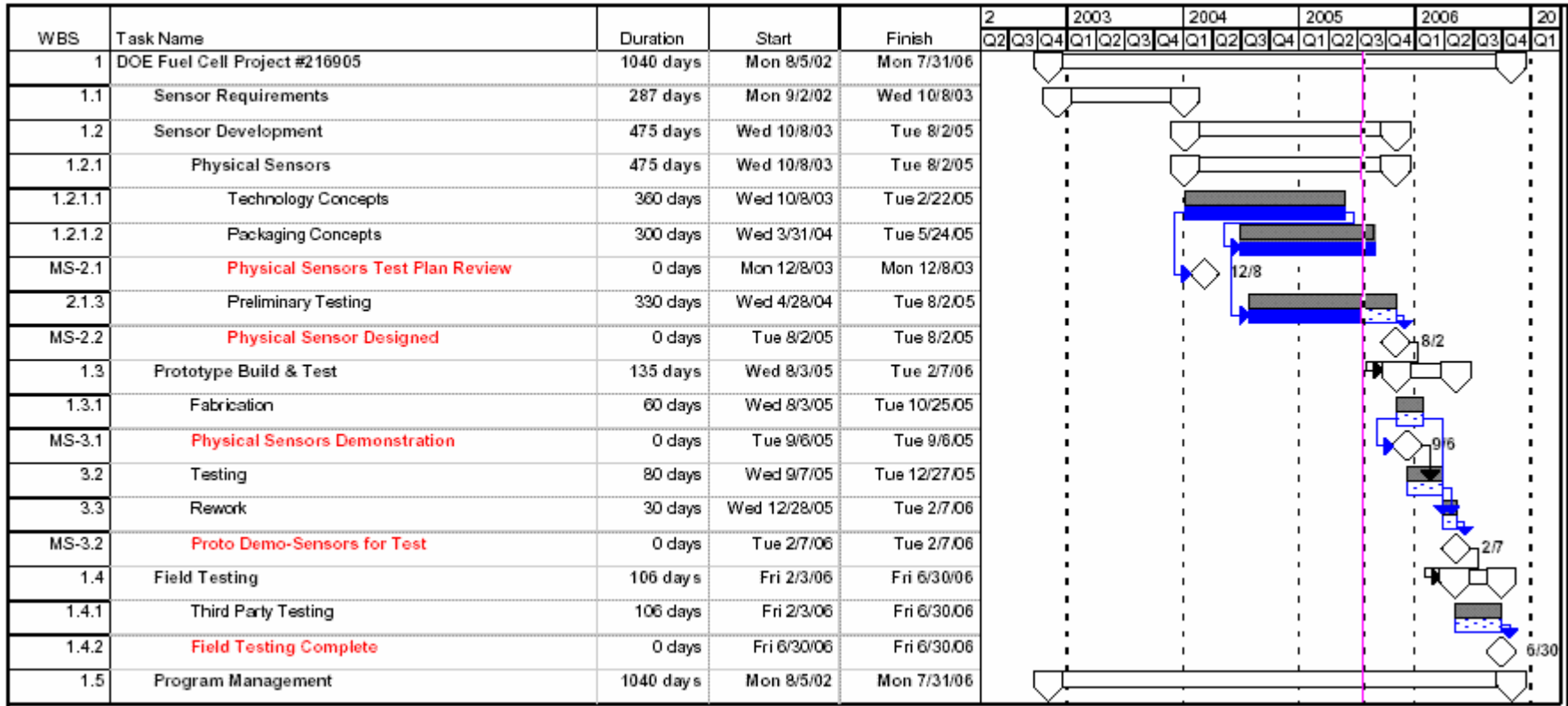

- 28 sensor per test group for 1000 hour temperature/humidity/bias
- 3 conditions, 85°C/85%RH, 85°C/65%RH, 100°C65%RH
- All sensors survived
- Virtually are sensors drifted up in sensitivity
- Sensors not heated on this initial test
- Conclusion1 a kind of burn-in or conditioning may be required
- Conclusion 2 We need to continue testing with heated sensors
- We passed gross H2 leakage testing
- Response time 6 seconds, not up to desired value (<5 sec)

Honeywell Advance Technology Laboratory; Minneapolis, MN

- Rugged flow die development for glass and silicon
- Investigation of advanced RH sensing films

United Technology Corporation; Hartford, CT

- Utilize UTC as a “test bed”

Ron Baxter Ph.D. Consultant

- RH Sensing Technologist

Field Testing:

- Ongoing effort to communicate development status
- Field test planning and execution

- **The challenge was to create a prototype for the Hydrogen test that permitted electrical connection from the connector to the sensor so that a low leak rate can be realized.**
- **Prototype design is that of a plastic firewall in which electrical terminals pass through, that have a low leak rate for H₂ by using a combination of epoxy and o-ring seals.**
- **Prototype is constructed using Radel R5100 which is a proven plastic for Fuel Cell construction.**
- **Tests will be conducted using three epoxy choices for terminal seal –**
 - Loctite FP4401**
 - Loctite 1059R**
 - Epon 815**

- **Three units will be tested using Mil Std–883. This is a Helium leak test using a pressure of 1 atmosphere and leak rate expressed in units of atmosphere cubic centimeters/sec.**
- **Mass Spectrometer detection employed and sensitivity down to 10^{-6} level will be measured.**
- **Pressures ranges of 1/2 , 1.0 and 3.0 atmospheres will be tested on the high pressure side of the firewall proving H₂ leak is a non-issue.**

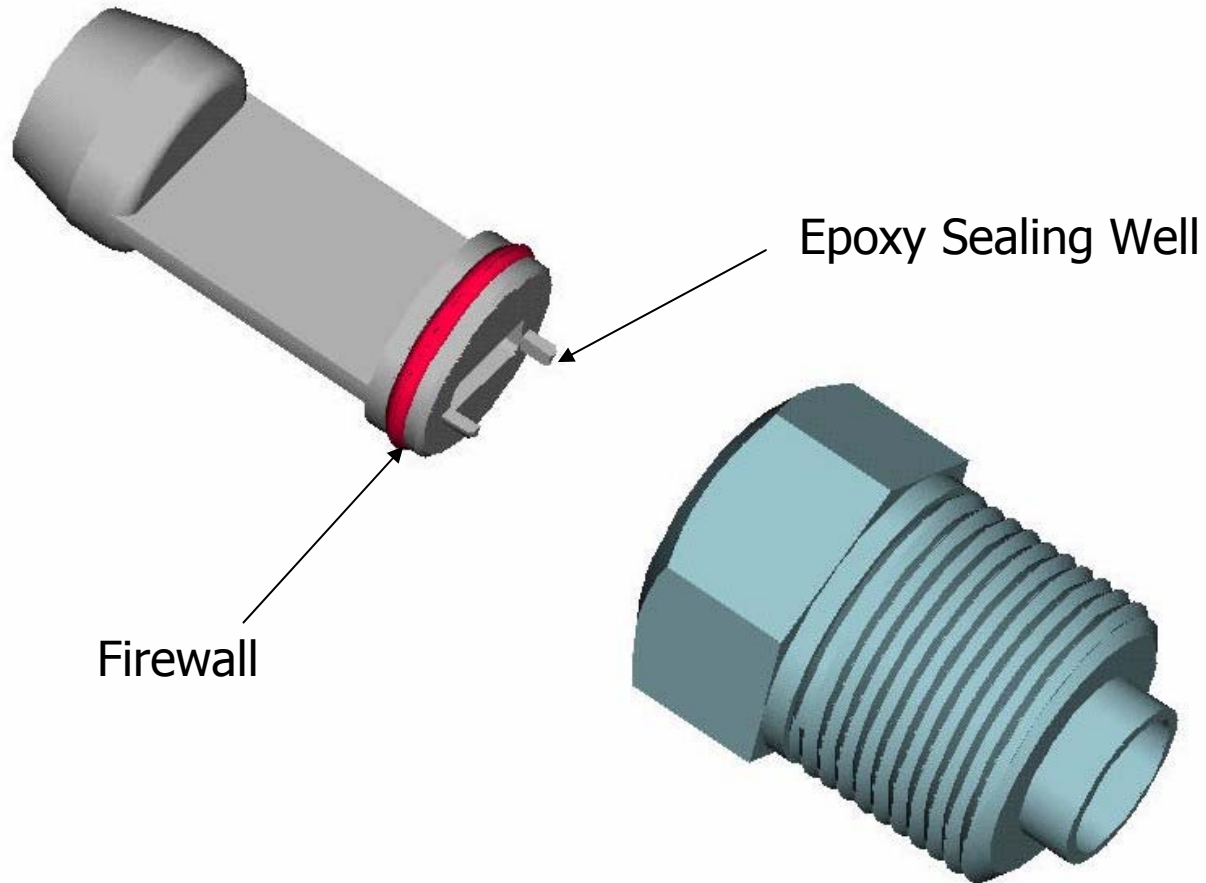

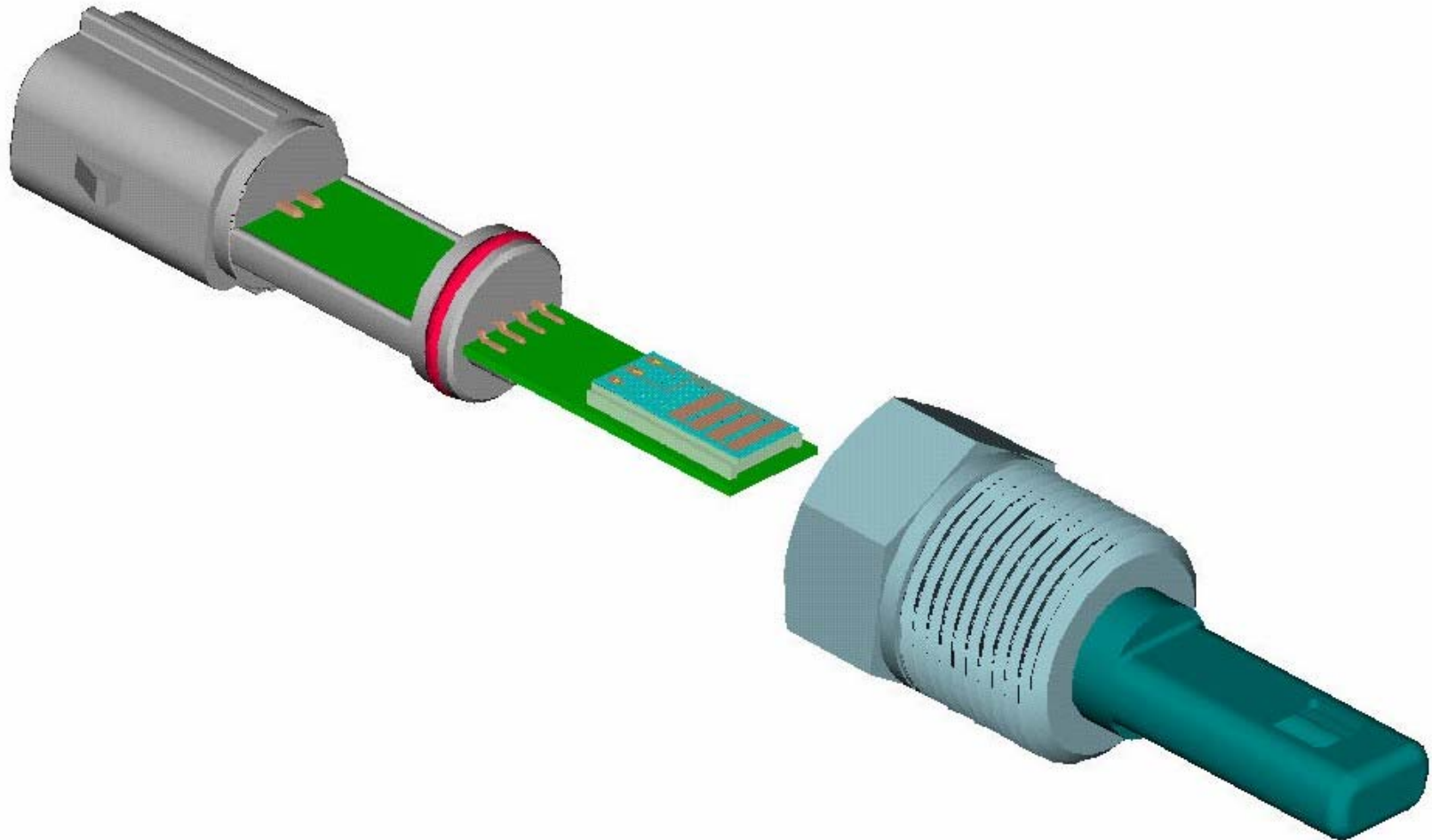

Humidity Sensor:

- Beta sensor fabrication and test
- Reduced “oven” size to reduce response time to <5 seconds
- Fabrication of Field Test Units
- Package soft tooling
- Circuit refine (advanced ASIC) and test
- Determine optimal heater temperature
- Humidity research
 - Accuracy improvement especially with uniform heating
 - Drift (Condensation)
 - Long term Stability at 85%RH/85°C
 - Response time improvement on Beta Configuration

- Standard Operating Procedures are followed in consideration of design and testing
- Ongoing risk assessment tools are utilized throughout the development process
- Material analysis has been performed for all media wetted surface materials
- Hydrogen exposure testing remains an ongoing element of all test plans
- All sensors are low voltage U.L. Class 2 designs

*Sensors being developed are prototype field test designs. Additional work may be conducted at the end of the contract to complete full environmental, EMC, and agency approval testing.

The most significant hydrogen hazard associated with this project is:

extremely gross hydrogen leakage through the package and into a general non-vented environment

Our approach to deal with this hazard is:

100% Leak testing on all Sensors

The overall design will be rugged enough to minimize crushing or other physical damage that would allow gross leaks. Such damage would also render the device inoperable, which can be used as a diagnostic