Solid Oxide Fuel Cell Development for Auxiliary Power in Heavy Duty Vehicle Applications

George N. Simopoulos

Delphi

May 24th, 2005

Project ID#: FCP30

Sponsor: U.S. DOE – Hydrogen, Fuel Cells and Infrastructure Technologies

DOE Technical Development Manager: John Garbak

DOE Program Manager: David Peterson, Ph.D.

Partners: PACCAR, Volvo Trucks North America (VTNA), & Electricore

This work is supported in part by the U.S. DOE under Cooperative Agreement

DE-FC36-04GO14319, and does not contain any proprietary or confidential information



◆ Program: Solid Oxide Fuel Cell (SOFC) for Auxiliary Power in Heavy Duty Vehicle Applications

– **Project ID:** DE-FC36-04GO14319

– **Funding:** \$4,700,000

– **Duration:** 48 Months – Project Start Date: September 2004

– **Industry Principal Investigator:**

George Simopoulos

Delphi: Technical Center Kokomo

Tel: (765) 451-3755

george.n.simopoulos@delphi.com

– **DOE Technology Development Manager:**

John Garbak

DOE: Washington DC

Tel: (202) 586-1723

john.garbak@ee.doe.gov



- ◆ Delphi has teamed with OEM's PACCAR Incorporated and Volvo Trucks North America (VTNA) to define system level requirements for a Fuel Cell (SOFC) based Auxiliary Power Unit (APU) for the commercial trucking industry. Delphi has enlisted Electricore to provide administrative assistance

VOLVO

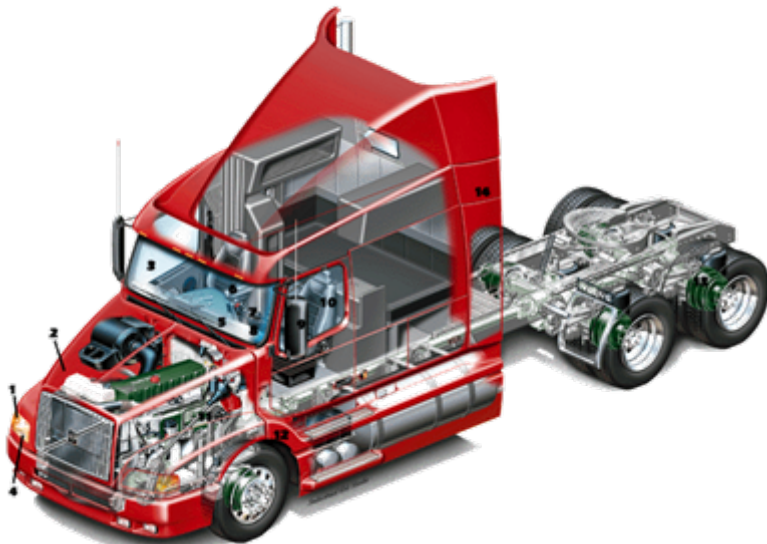

**Volvo Trucks North America (VTNA),
Greensboro, NC**



PACCAR, Bellevue, WA



Development Strategy Overview: Development of core sub-system building blocks that will be utilized in systems for each of the target markets

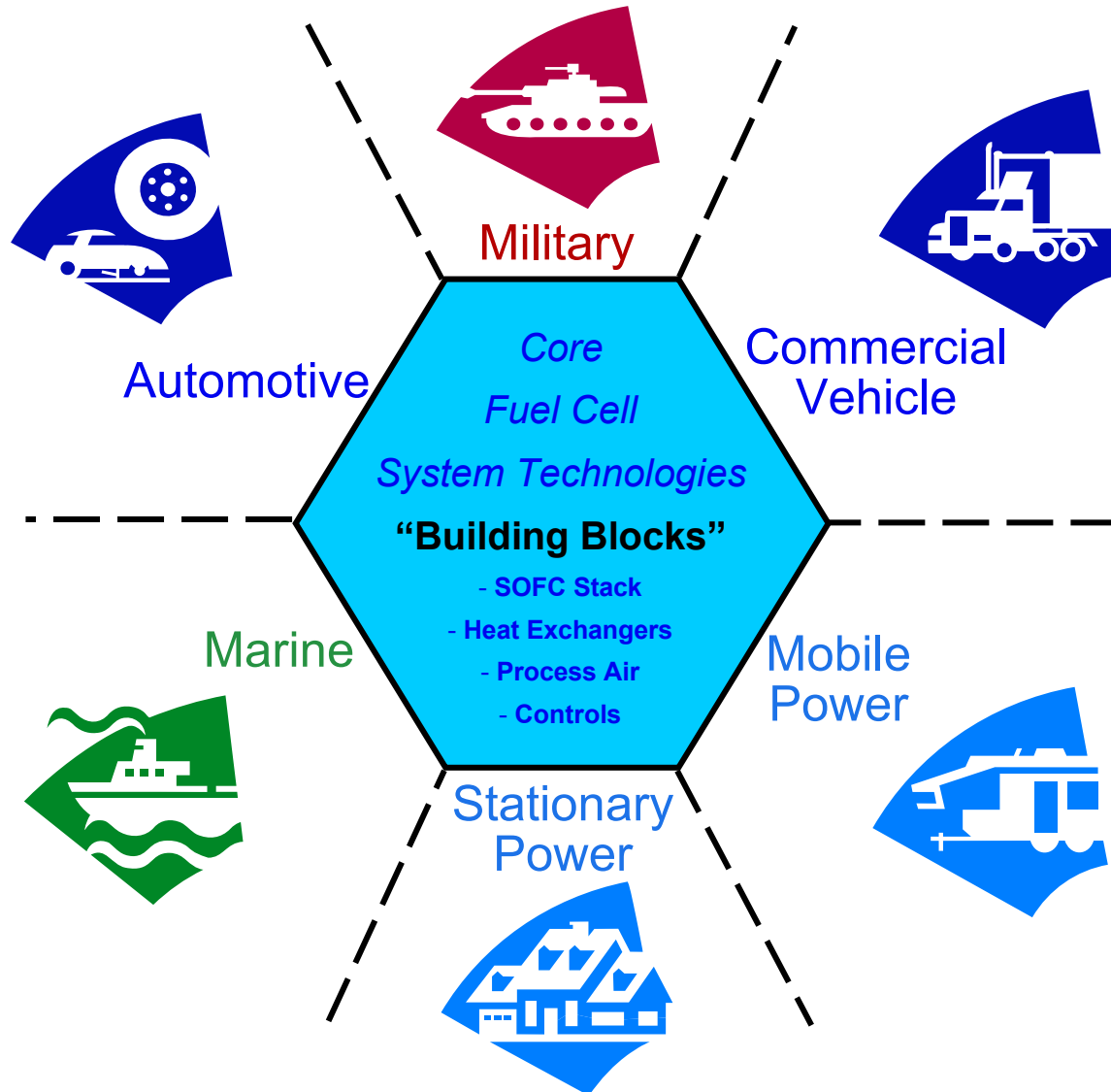

Each application adjusted for:

- Fuel Type
- Electrical Configuration
- Application Environment
- User Interface



Program Objectives:

- ◆ To demonstrate an SOFC APU capable of operating on low sulfur diesel fuel, in a laboratory environment, for the Commercial Trucking Industry.
 - Develop APU system requirements and concepts with major truck OEMs input
 - Design, test and develop the needed subsystems for the selected concept
 - Build and bench demonstrate the selected *diesel fueled* APU system to the DOE



- ◆ Program Technical Approach will involve extracting hydrogen and CO from diesel fuel in a catalytic operation through a Reformer. The output gas from the Reformer will be sent to the fuel cell stack and converted to electrical energy

- ◆ The following tasks will be completed during this program
 - *Application Requirements with OEM Input*
 - *APU System Mechanization Concepts*
 - *APU System Requirements, Concept Evaluation, and Selection*
 - *APU System Design and Layout*
 - *Develop Subsystem Requirements and Development plan*
 - *SOFC Hardware Design and Build*
 - *Subsystem Test Fixture Hardware Build*
 - *Subsystem Testing and Development Iterations*
 - *System Module Testing and Development*
 - *Full APU System Testing and Development*
 - *APU System Laboratory Demonstration with Simulated Load Cycles*
 - *Final Report and Presentation*



- ◆ Key areas of collaboration with OEM's PACCAR and VTNA include:
 - Performance and functionality requirements
 - » Power output, durability, response times, expected loads
 - Vehicle operating environment requirements
 - » NVH, temperature, fuel quality, exposure
 - Electrical integration and mounting options for selected vehicles
 - APU physical requirements
 - » Allowable mass, volumes, connection locations
 - Efficiency requirements at peak power and over usage cycles
 - Regulatory issues: exhaust emissions, noise, safety
 - Maintenance and service interval issues



Vehicle Electrical System Diagram

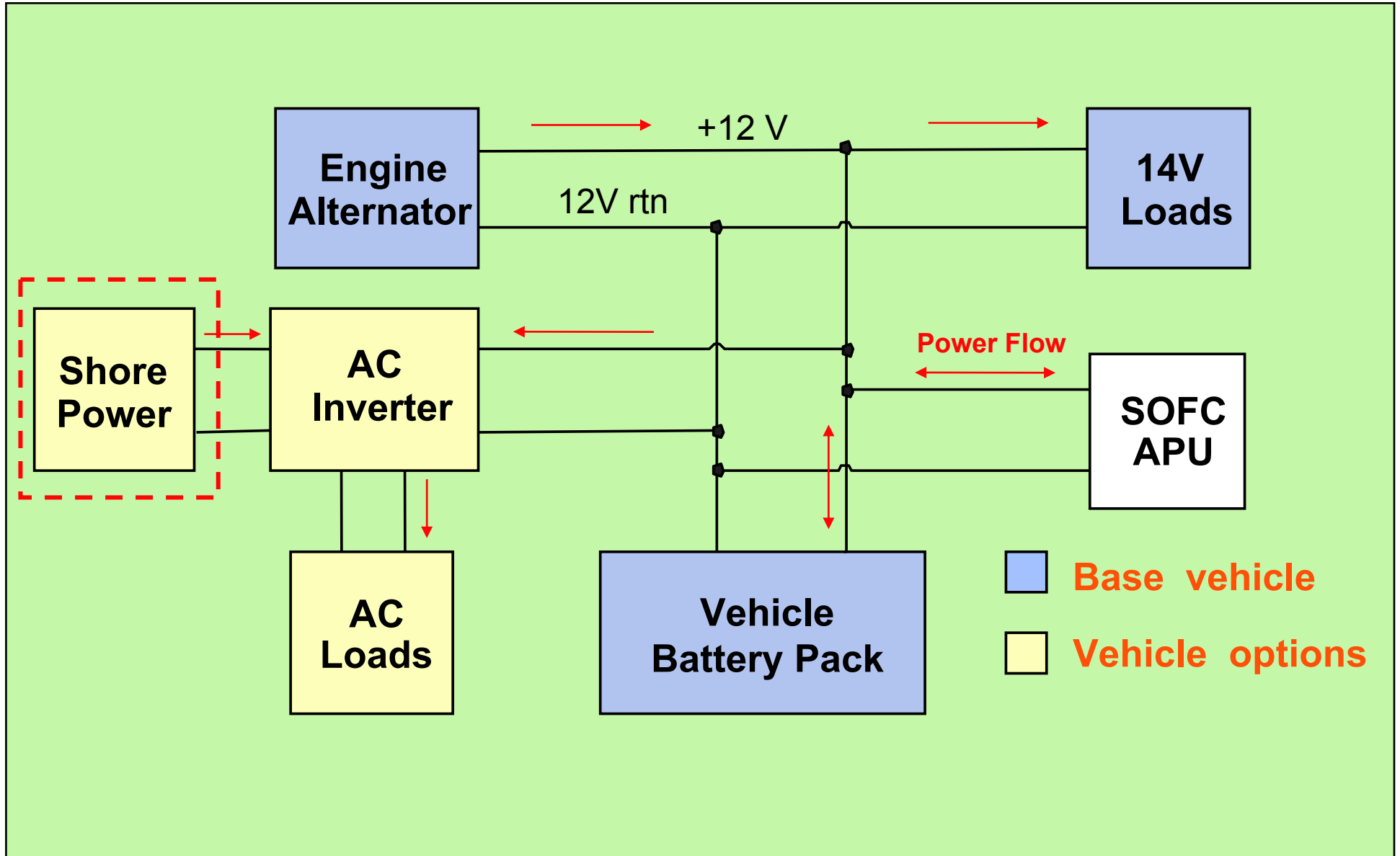



Delphi SOFC APU system architecture is divided into 3- major modules:

◆ **Hot Zone Module (HZM):**

- SOFC stack module system
- Fuel Reformer system: Diesel fuel processor with anode tailgas recycle operation capacity
- System Heat Exchanger and Component Manifold
- System Tailgas Combustor: Close coupled with reformer (heat transfer and start-up)

◆ **Plant Support Module (PSM):**

- Balance of Plant: Consists of fuel injector, sensors, pre-heaters, etc.
- Power Conditioner: Converts the stack voltage to a stable DC voltage
- APU System Controller: Controls the SOFC stack and reformer operation
- Anode Recycle System: Added system efficiency and reformer operation benefit

◆ **Application Interface Module (AIM) and Product Enclosure:**

- AIM is closely integrated with PSM but remains customized for power needs
- Product Enclosure solves several issues: Serves as module frame and application cover
- Air filtration (serviceable element)

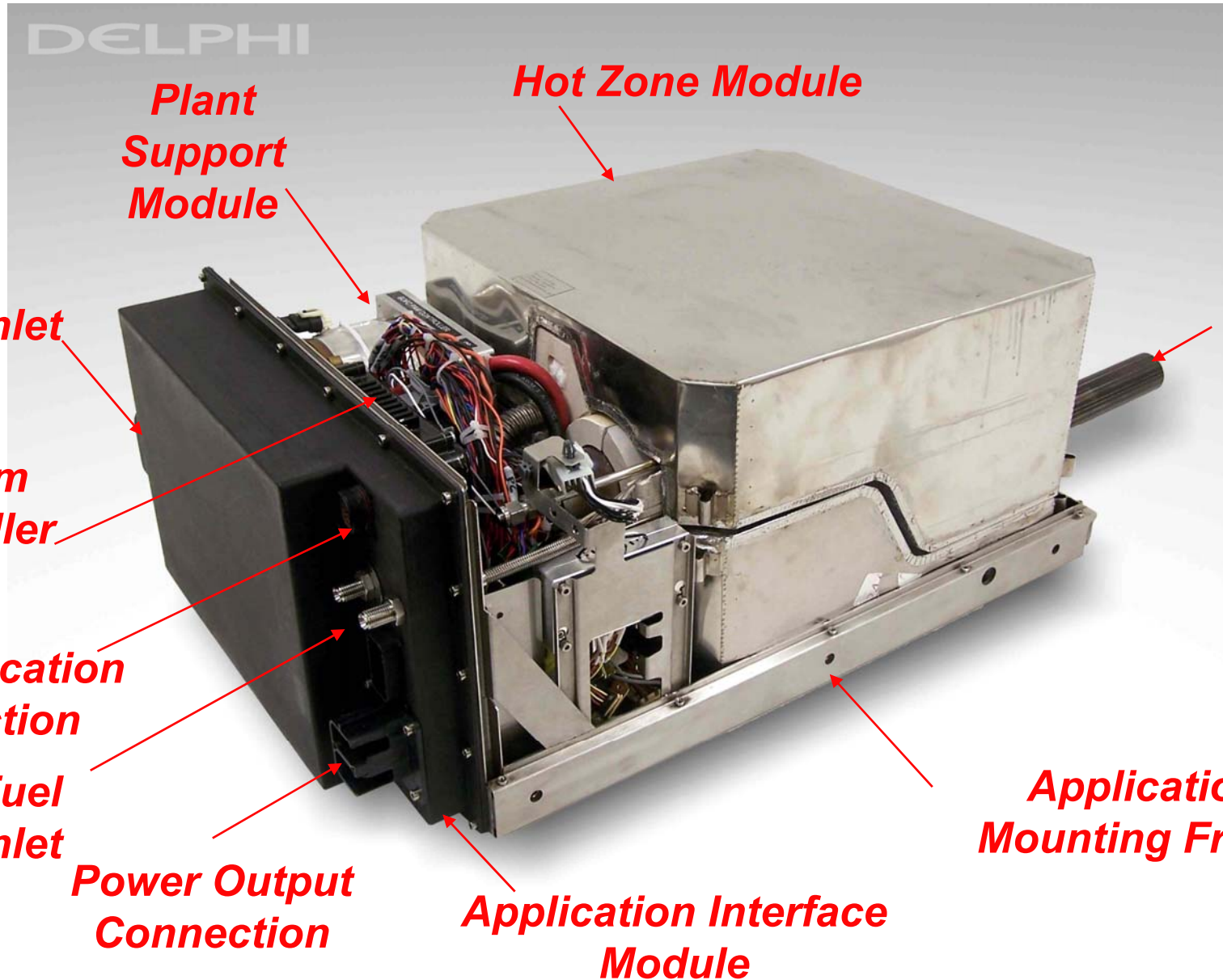

DELPHI

Plant Support Module

Hot Zone Module

Air Inlet

APU Exhaust

System Controller ECU

Communication Connection

Fuel Inlet

Power Output Connection

Application Interface Module

Application Mounting Frame



◆ **Startup and initialization mode**

- The SOFC accessories will be powered up electrically using the vehicle battery power and bring the SOFC up to operating temperature.

◆ **Power mode**

- The SOFC will provide electric power to the vehicle using vehicle diesel fuel to create power.

◆ **Standby / Idle mode**

- The SOFC will maintain its temperature within operating levels using diesel fuel and vehicle electric power so that the SOFC will be ready to provide electric power upon request.

◆ **Shutdown mode**

- The SOFC will cool down to ambient temperature at a rate determined by the controller.



Program Accomplishments:

Milestone - 1: Requirements Review

- ◆ Collaboration with OEM partners PACCAR and Volvo Truck NA are underway to finalize application requirements for the SOFC APU system
 - Quantifying power, load profile, operating conditions, durability requirements, operator interfaces, safety parameters, volume, mass and mounting requirements for various truck models

- ◆ Completion of Milestone –1 (Requirements Review) Meeting with DOE and OEM partners was held on April 14th, 2005



◆ Remainder of FY 2005

- Development of Vehicle System and APU System Mechanization Concepts
- APU System Requirements
- Milestone #2 Review

◆ FY 2006

- APU Design and Layout
- Subsystem Requirements Document and
- SOFC APU Subsystem Hardware Design and Build



- ◆ In the DOE SOFC APU program hydrogen and CO is extracted from diesel fuel in a catalytic operation in the Reformer. This process makes storage of pure hydrogen unnecessary
 - The Reformate of the Diesel fuel with Partial Oxidation has approximately the following constituents:
 - » *About 25% Hydrogen*
 - » *About 20% CO*
 - » *3% Steam H₂O*
 - » *Remaining is N₂, and other species*



- ◆ The most significant hydrogen hazard associated with this project is:
 - During warm-up, at temperatures below 500°C, any hydrogen leaked from the reformer or fuel cell stack could collect in the Hot Zone module. As the temperature rises above 500°C the gasses could combust causing damage

- ◆ Our approach to deal with this hazard is:
 - Sealing technologies are being implemented to avoid leakage maximize containment
 - The SOFC APU can be instrumented with H₂ and CO sensors that would detect leakage. The electronic control unit would then take appropriate action to shut down the unit

Delphi is committed to working with DOE to develop the SOFC APU technology for a cleaner and more fuel efficient commercial truck of the future



DELPHI

PACCAR

VOLVO

