



Standardized Testing Program for Chemical Hydride and Carbon Storage Technologies

Richard A. Page

Michael A. Miller

Southwest Research Institute

San Antonio, TX

Program Review

May 25, 2005

This presentation does not contain any proprietary or confidential information

Project ID #
ST21

Overview



Timeline

- March 2002 start date
- March 2006 end date
- 77% complete

Budget

- \$3M total funding
 - \$2.4M DOE share
 - \$0.6M Cost share
- \$700K FY04 Funding
- \$358K FY05 Funding

Barriers

- Barriers addressed
 - O. Test Protocols and Evaluation Facilities
 - M. Hydrogen Capacity and Reversibility
 - F. Codes and Standards

Partners

- Texaco Ovonics Hydrogen Systems
- The National Hydrogen Association
- International collaboration with the European Commission-Joint Research Center



Need and Objectives

DOE Program Need

An ability to accurately and independently assess the performance of the wide array of solid-state storage materials and focus efforts on those that show the most promise in meeting the 2005, 2010, and 2015 performance targets.

Project Objectives

- Develop and operate a standard testing and certification program specifically aimed at assessing the performance of emergent chemical hydride and carbon adsorption/desorption hydrogen storage materials and systems.
 - Complete and test sub-assemblies
 - Refine SOPs using reference materials
 - Begin round-robin testing
 - Finalize all SOPs
 - Fully operational lab



Approach

- Develop facility and protocols to characterize storage capacity of small quantities (mg to g) of solid state storage materials
 - *Storage capacity* of materials measured by three independent techniques
 - *Gas speciation* capability on all instruments
 - Instruments and test protocols verified with *material standards* and *round robin testing* program
- Develop facility and protocols to characterize the performance of full-size (5 kg H₂) storage systems
 - *System capacity* measured *volumetrically* and with *Coriolis flow meters*
 - *Rapid fill* (refueling) measured with *Coriolis flow meters*

Design Philosophy / Goals of Laboratory & Sub-Assemblies



- Safety first
 - Hazards effects mitigation
 - Two-level redundant sensor & alarm system
 - Emergency ventilation system
 - Control system redundancies and user interlocks
 - Stand-alone power source
- Ultra-High purity (UHP) source gases, materials, and assembly procedures
- UHP manifold with pneumatic actuation
- Continuous process gas exhaust
- PLC-driven manual and automated computer control system for UHP manifold processes
- Gas sampling and purity monitoring system
- Manifold-based gas purification (purge, evacuate, heat, purify)
- Array of high-pressure, vacuum compatible analytical capabilities (gravimetric, volumetric, desorption mass spectrometry)
- Independent mass spectrometry for volumetric and gravimetric analysis
- Sample activation capabilities & safe handling of materials

Laboratory Facility



H₂ and He Tube Trailers (Revetment)



Front

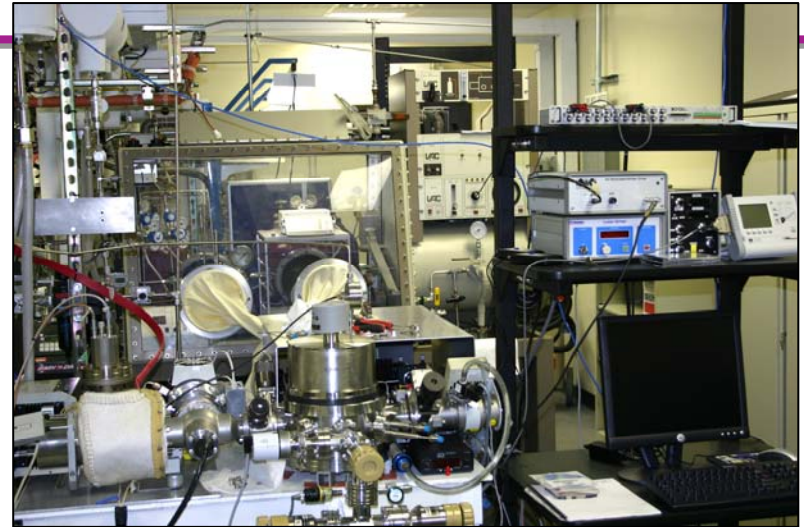

Laboratory

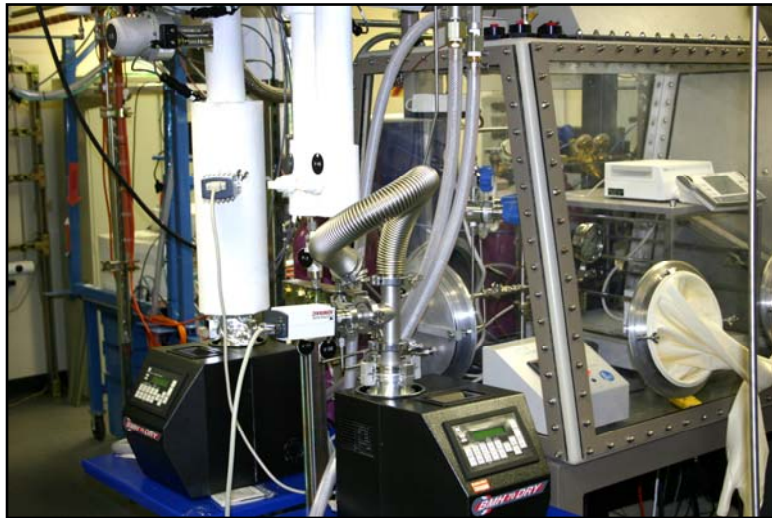

Left Side

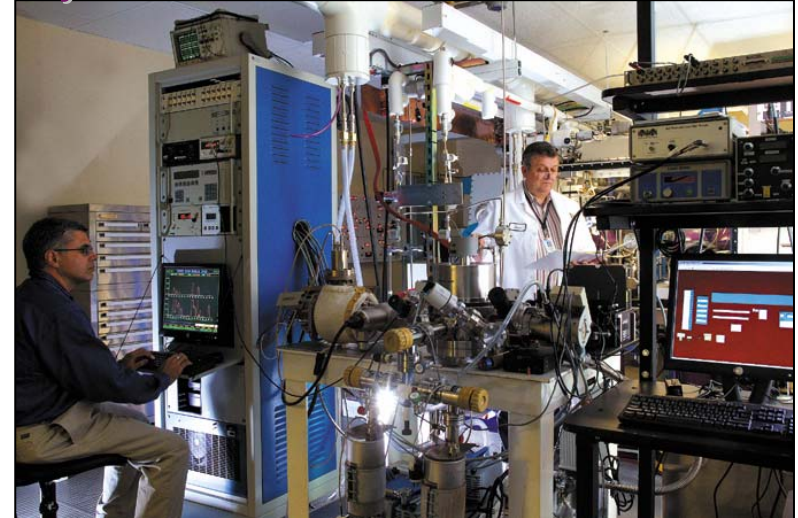

Right Side



Ultra-High Purity Gas Manifold

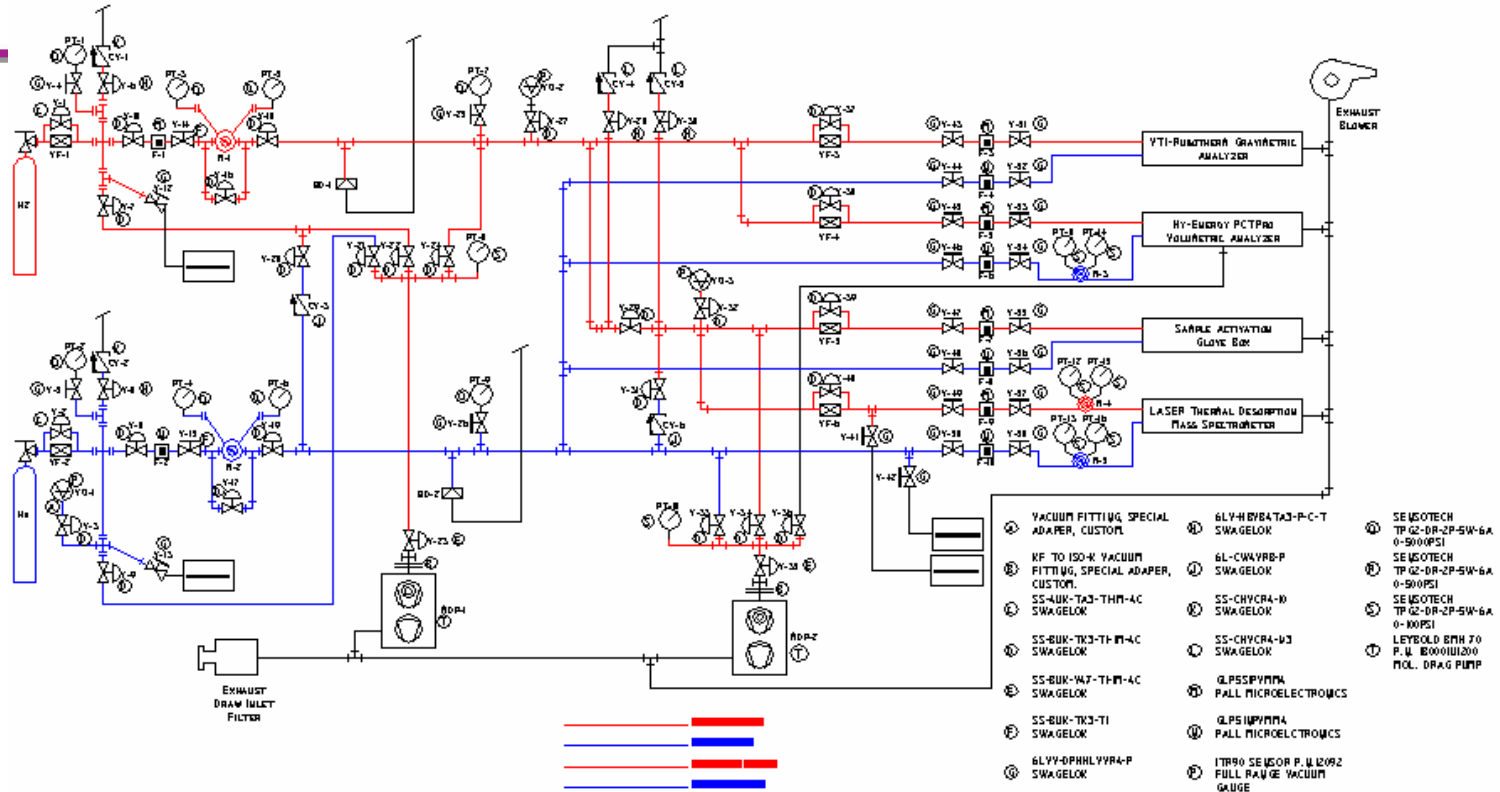

- Semiconductor-grade tubing and components
- Point -of-use gas purifiers (redundant)
- Purge /Pump/Heat conditioning
- PLC /LabView control of manifold operations
- Self regulating heat trace (Raychem XTV, 120°C max)

Gas Sampling System

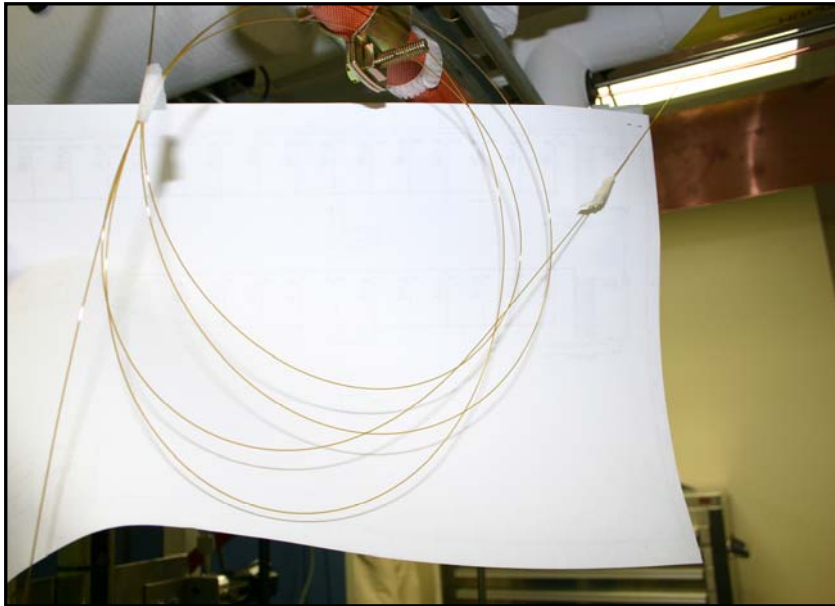

Capillary Fused Silica



Sub-Manifold

- UHP capillary fused silica (deactivated) sub-manifold
- Thermally regulated
- Low dead volume, short residence time to MS (multisampling interface)
- Capable of sampling H₂ or He manifold gas at full pressure (~2500 psig)
- Sampling ports at outside inlet lines also available

High-Pressure Gravimetric Sorption Analyzer



- Gravimetric measurements of sorption/desorption
- Rubotherm magnetic suspension balance
- Mass spectroscopic speciation
- Milligram – gram sample size
- 10^{-6} g resolution
- 150 atm operating pressure
- Cryo to 500°C
- Located within a glove box for air sensitive samples
- Estimated accuracy of 3×10^{-4} wt % for 300 mg sample at 1 atm



Volumetric Sorption Analyzer

- Volumetric measurements of sorption/desorption
- 200 bar, 400°C
- Estimated accuracy of 0.2 wt.% with 300 mg sample at 100 atm
- Pressure-composition isotherms, kinetics, and cycle-life measurements



Laser Thermal Desorption Mass Spectrometer System



- Speciated thermal desorption measurements
- Laser sample heating
 - Minimize thermal mass
 - Enhance thermal coupling
- Optical envelope for laser heating of sample
- Cryo to vaporization
- Calibration with NIST traceable calibrated leaks
- Estimated accuracy of 1×10^{-3} wt% for 300 mg sample

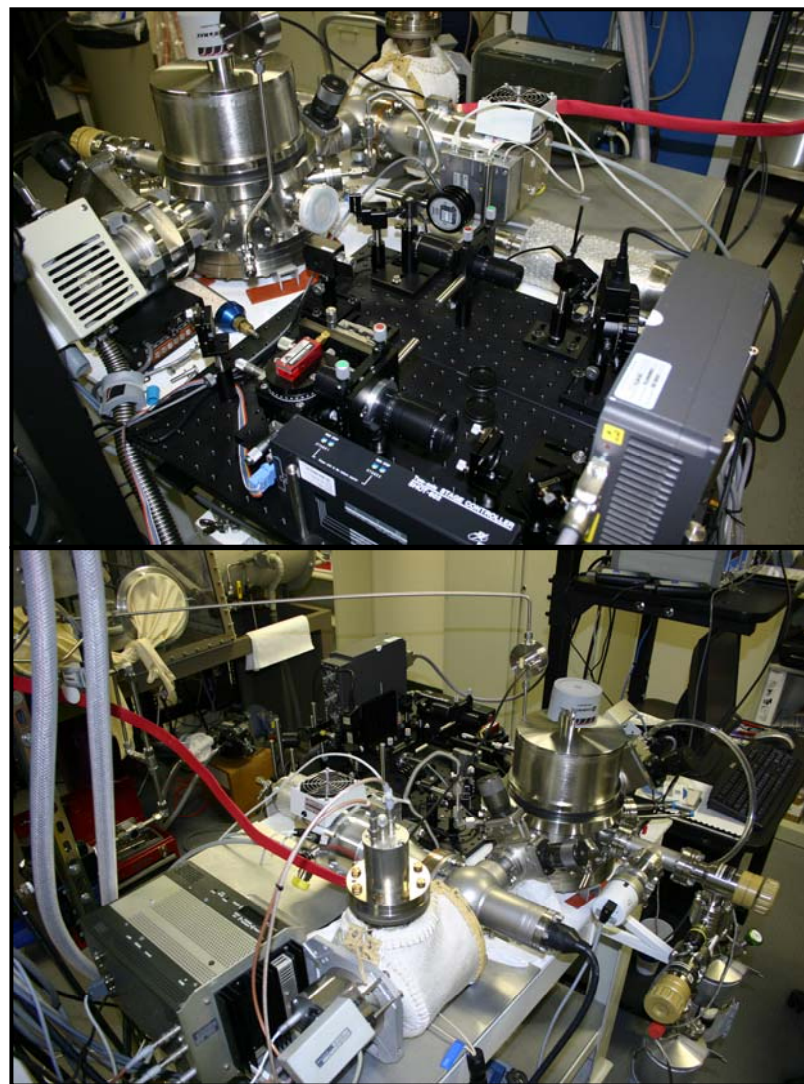

Sample Activation

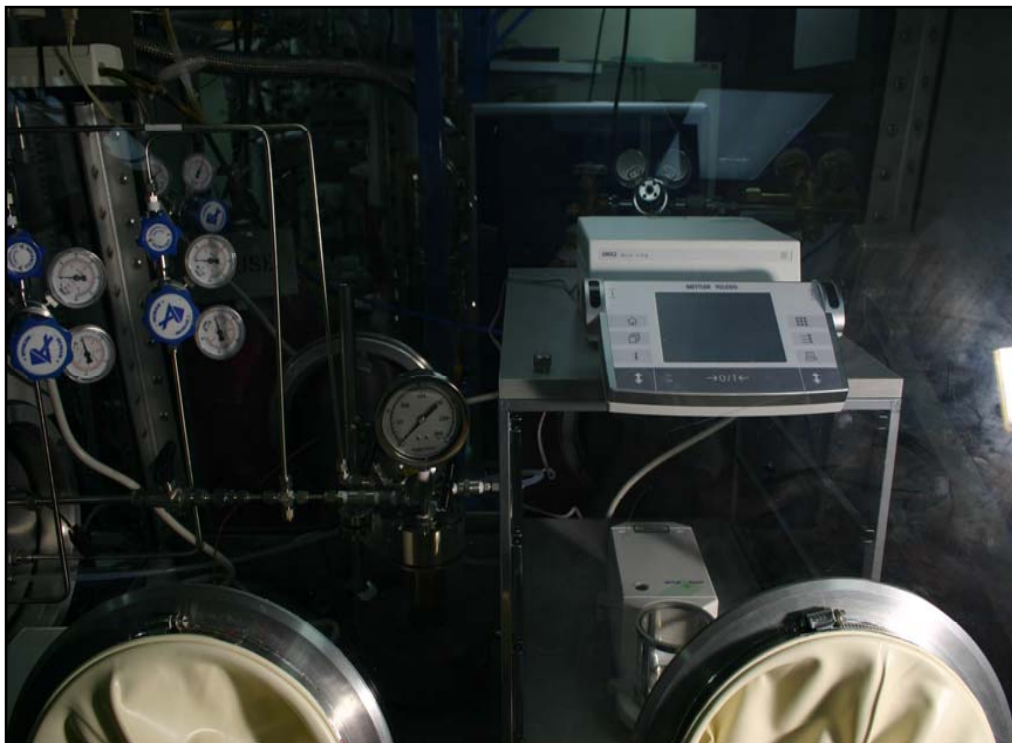

Sample Manipulation
Glove Box

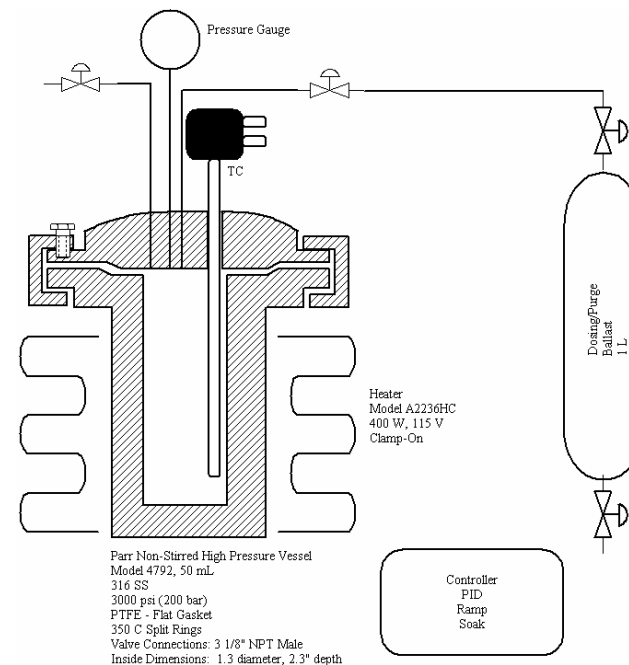

Reactor Vessel



Protocol Development

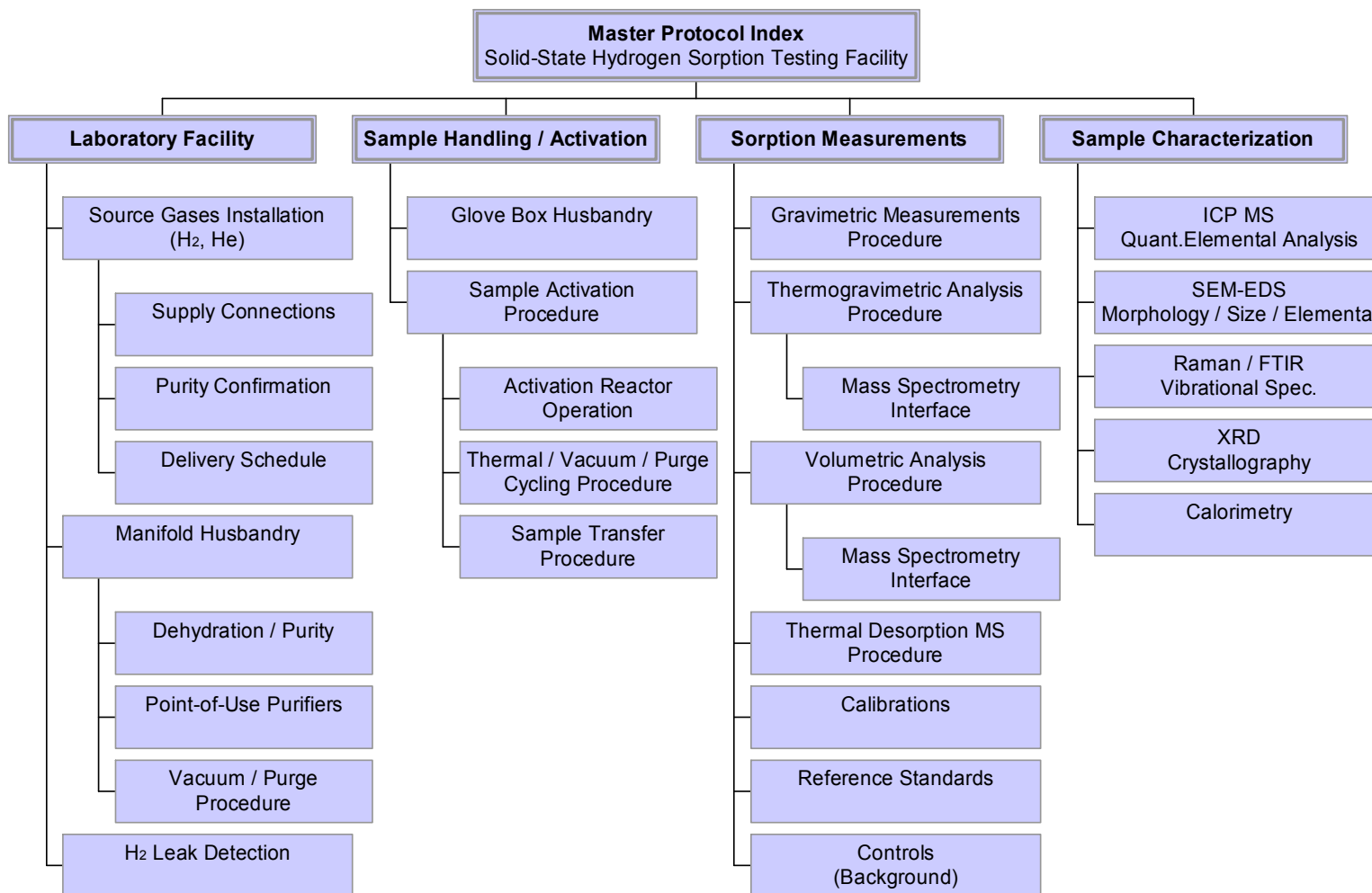



Program Milestones

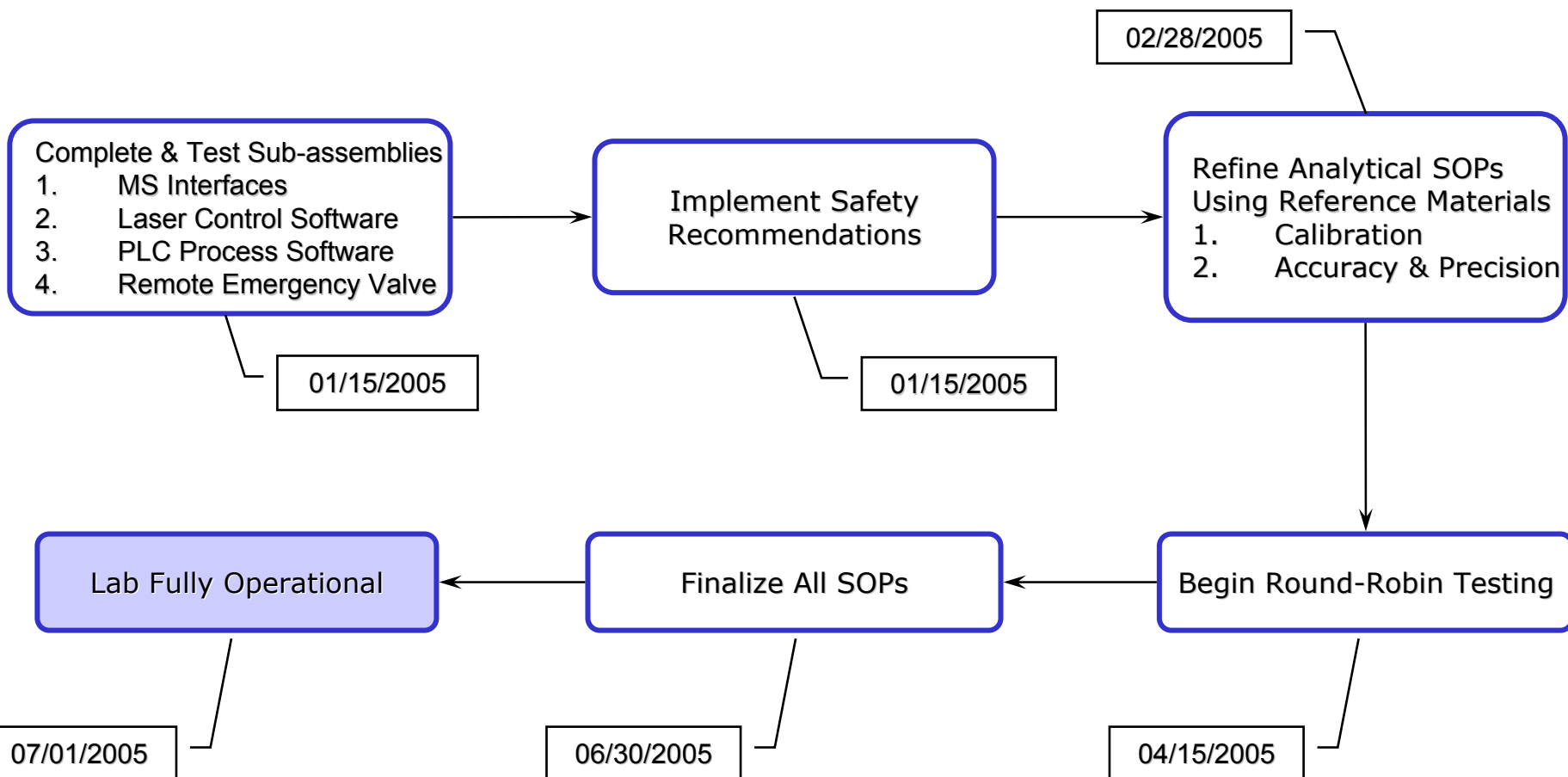



Round-Robin Testing

- Double-blind testing program
- Program administered for DOE by George Thomas
- Materials and laboratories have been selected
- Materials cover a wide range including carbon and hydrides
- Round-robin testing currently in progress

Measuring Storage System Performance



Characterization of the performance of full-scale storage systems to include:

- Sorption/desorption performance
- Refueling time
- >35 atm operating pressures
- 5 kg delivery in <5 min



Full-Scale Testing Facility



- Storage system to be inserted into a containment vessel designed to handle a full gas load from the storage system
- Containment vessel to be filled with inert gas to prevent ignition of any accidental release from the storage system
- Containment vessel containing storage system to be lowered into 24 inch diameter schedule 40 pipe section surrounded by 12 inches of concrete and buried in the earth
- All monitoring and control of the test will be performed remotely



Reviewers' Comments

Need to put more thought and planning on measuring heats of H₂ adsorption. It's critical that there be the means to measure this heat of H₂ adsorption.

- The heat of H₂ adsorption can be determined indirectly from van't Hoff plots, which can be obtained on both the volumetric and gravimetric instruments.
- Currently exploring the possibility of adding a high pressure flowing calorimeter for direct measurements.

Consider doing some correlation with test facilities at research providers.

- A number of the research providers are likely involved in the round-robin validation.
- Will certainly consider performing correlations with other research providers on a case-by-case basis.



Future Work

- Complete round-robin validation (May, 2005)
- Finalize SOPs (June, 2005)
- Initiate testing of materials (July, 2005)
- Complete construction of facility for testing of full-scale storage systems (September, 2005)



Publications and Presentations

- “National Testing Laboratory for Solid State Hydrogen Storage Technologies”, NHA Annual Hydrogen Conference, March 30, 2005



Hydrogen Safety

- *A failure modes and effects analysis was performed prior to the completion of the facility.*
- *Corrective actions were developed and instituted for the potential failure modes with the highest RPN numbers.*

The most significant remaining hydrogen hazard associated with this project is:

- *The remaining failure modes with the highest RPN numbers are associated with hydrogen fires/explosions due to leaks or failures of various components in the hydrogen delivery system.*



Hydrogen Safety

Our approach to deal with this hazard is:

- • *The hydrogen manifold has been designed with both active and passive safety features to make a large release of hydrogen into the laboratory unlikely.*
 - *i. Passive velocity fuses to stop flow whenever a large flow is experienced*
 - *ii. Two layer hydrogen detection system including a highly sensitive local detection capability*
 - *iii. PLC control of the supply manifold with automatic shutdown in the event of a hydrogen alarm*
 - *iv. UPS and diesel generator backup of all critical systems*
- • *We have also developed a safety SOP that defines correct operational procedures with respect to hydrogen usage in the facility.*