

Next Generation Hydrogen Storage Containers

Principal Investigator: Andrew H. Weisberg
Collaborator: Blake Myers

Lawrence Livermore National Laboratory

May 25, 2005



Project ID #
STP1

This presentation does not contain any proprietary or confidential information

This work was performed under the auspices of the U.S. Department of Energy
by University of California Lawrence Livermore National Laboratory under contract No. W-7405-Eng-48



Timeline

- Start date: October 2004
- End date: September 2009
- Percent complete: 15%

Budget

- Total project funding
 - Potential future DoD funding
 - DOE is only sponsor to date
 - No “Contractor Share”
- Funding received in FY04: \$225K
- Funding for FY05: \$189K

Barriers

- Barriers addressed
 - **B** Weight and Volume
 - **D** Durability (cycling, mfg., crash)
 - **E** Refueling Time (hydrides + C)
 - **H** Sufficient fuel storage for acceptable vehicle Range
 - **I** Materials (strength, T, perm'y)
 - **K** Balance of plant (BOP) components (liners, mounting, P+T control, heat transfer)
 - **M** Hydrogen capacity and reversibility

Partners

- Spencer Composites (new composite materials and unprecedented processing)
- Materia (new matrix mat'ls)



Find the best

- *Find and investigate the **best** container alternatives for storing hydrogen. {funding withdrawn for theory in 9/04}*

Learn how to build it

- *Evaluate the most attractive performance and **manufacturing processes** capable of improving upon conventional containers for hydrogen fueled motor vehicle applications. {sole DOE funded objective FY05}*
- *Seek fundamental **safety innovations** enabled by compressed hydrogen storage. {no funding after FY00}*

Approach



- Theory #1 = valid tradeoff of mass vs. volume
 - Also can trade off power and cost for any artifact
 - Intended to find shape of ρ vs. %-mass feasible corner
- Theory #2 = top-down container breakthrough
 - Violates the unfounded-but-intuitive assumption that the container surrounds its contents {Nature does it !}
 - Carries pressure+gravity+acceleration+external loads through the internal volume of radical containers
 - Mass and heat flow can also exceed diffusion this way
- Experiments {can't buy the parts to prove #2}
 - Fundamental progress seeks new class of structures
 - Mass production required to win on cost, not for proof
 - Unknown unknowns debuggable via R+D cost triage
 - Proof of concept at ~30X scale + component testing

Technical Accomplishments



- Closed out Theory #1 activities with major result :
 - The “feasible corner” really is square for cars+SUV's
- Sorted out Experimental Objectives for Theory #2
 - Chose best late-2004 guess for Space Group of lattice
 - Preserved some possibility of proving major safety gain
- Planned route to Proof of Concept -> 3 Generations
 - All known technical risks reduced by sequential progress
 - Quantitative performance models validated in Gener'n 1
 - Consequences of costly Gen. 1 tooling determine Gen. 0
- Design completed for Generation 0 test articles
 - Relies on rapid prototyping capabilities already in place
- Test articles prototyped with quantitative functions :
 - Pressure containment, strain mimicry, pre-load control
- Re-design underway to add heat transfer features



- **Figure of Merit for containment of pressure loads**
 - FoM = PbV/W limits mass of any contents / total mass
 - LLNL set the record on PbV/W for all tanks (in 2000)
 - Since then, further 60% is possible from new materials
 - FY04 established macrolattice mass $\sim 5\% <$ tanks
- **Cryo-compressed and supercritical hydrogen**
 - Added curves for cold physical hydrogen storage to the ρ vs. mass-% plane plot {for Tech Team in 9/04}
 - These curves show one feasible route to 2015 Target
- **Technical Risk Analysis completed at top level**
 - Yields high confidence that supercritical hydrogen storage is feasible and affordable in mass production
- **Macrolattice Features list extended {for APS 3/05}**
- **New manufacturing sequence for macrolattices**

Revisit 2003 Strategy for Exceeding DOE Targets



ρ_E Very loud applause at Review in Berkeley 2 years ago:

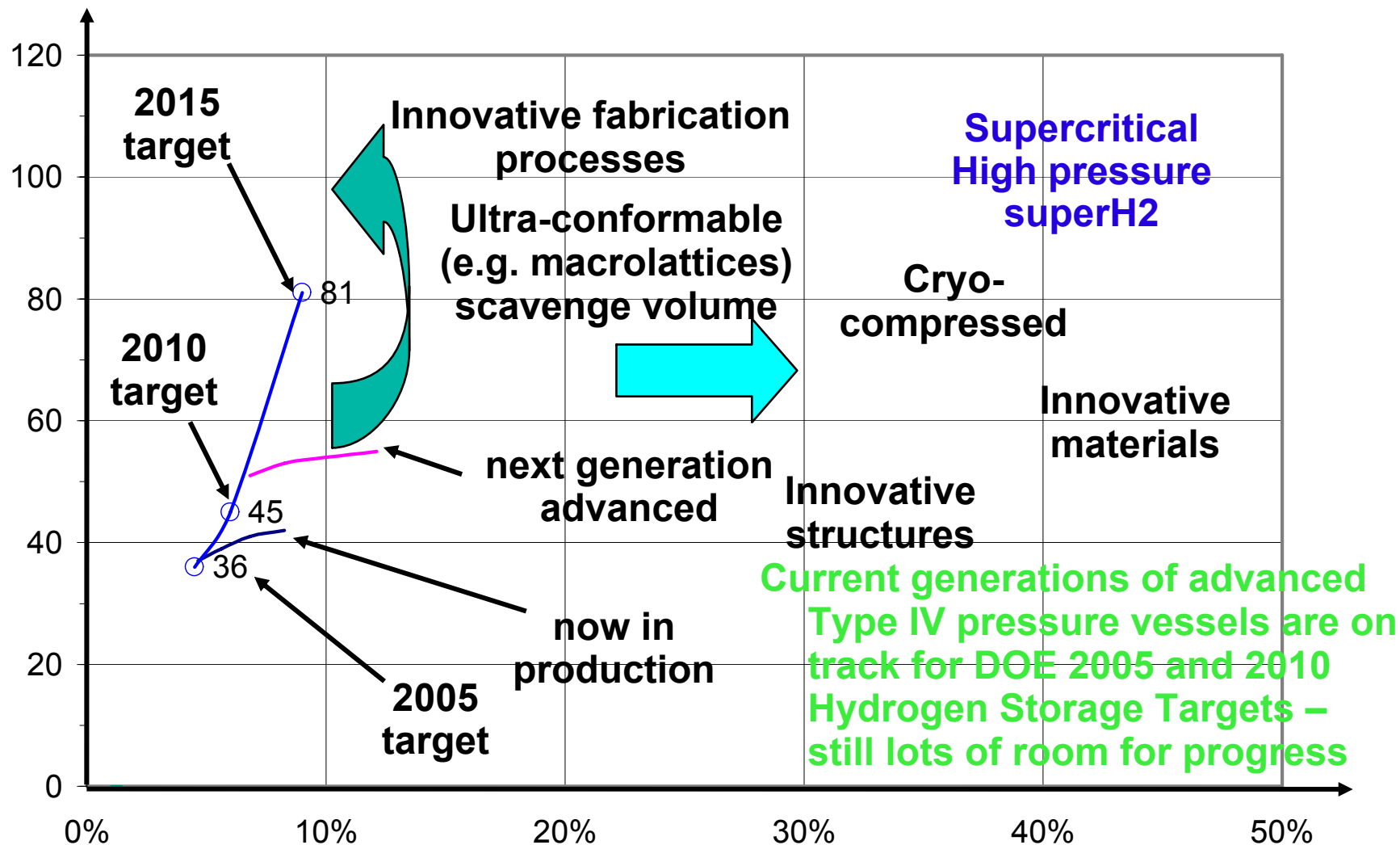



“Turn to Dust” Failure Mode

Successful (mass record set in June 2000)
tanks turned to dust in a single frame
on high speed cameras

This potentially *benign* failure mode
displayed almost no localized fracture,
releasing fine ‘shrapnel’ that can be
easily stopped by thin shielding

The “missing 7%” *may* be understood

Stress ratio (helical / hoop) “too high”

Dome failure activated – high dispersion

Real manufacturing problems on dome

A poor trade off : wider tows cost less but
imply more severe 3D effects in dome

This is a repeatable class of failure modes
with the potential for new Science and
Engineering (designer failure modes)!



Optimization with Constrained Range and Acceleration Solves for the Best Structural Geometries to Store Hydrogen



- A wide range of structures can contain compressed hydrogen. Within a given family of structures, both continuous and discrete valued parameters must be specified to fully describe a design. Once described, the performance of that structure can be confidently calculated.
- Partitioning out the combinatorial optimization of all discrete parameter choices, and the Optimal Control problem during a vehicle mission, the vehicle designer should seek the best continuous parameters at the extrema of a cost function, subject to various constraints.
- The Calculus of Variations solves this constrained optimization problem including relative sizing of subsystems and consumer performance preferences – but that solution is only as good as its costs and constraints. Range, velocity, and acceleration constraints make sense as a basis for equivalent vehicle value.
- Roughly a dozen design variables must be optimized to specify a hydrogen fueled vehicle design. Structural hydrogen storage contributes at least one parameter (e.g. failure pressure) but could routinely require many more. Material properties can be optimized in the same procedure, although they are generally considered as discrete choices whose performance consequences can only be compared.

DOE Targets – by Industry Consensus in 2003

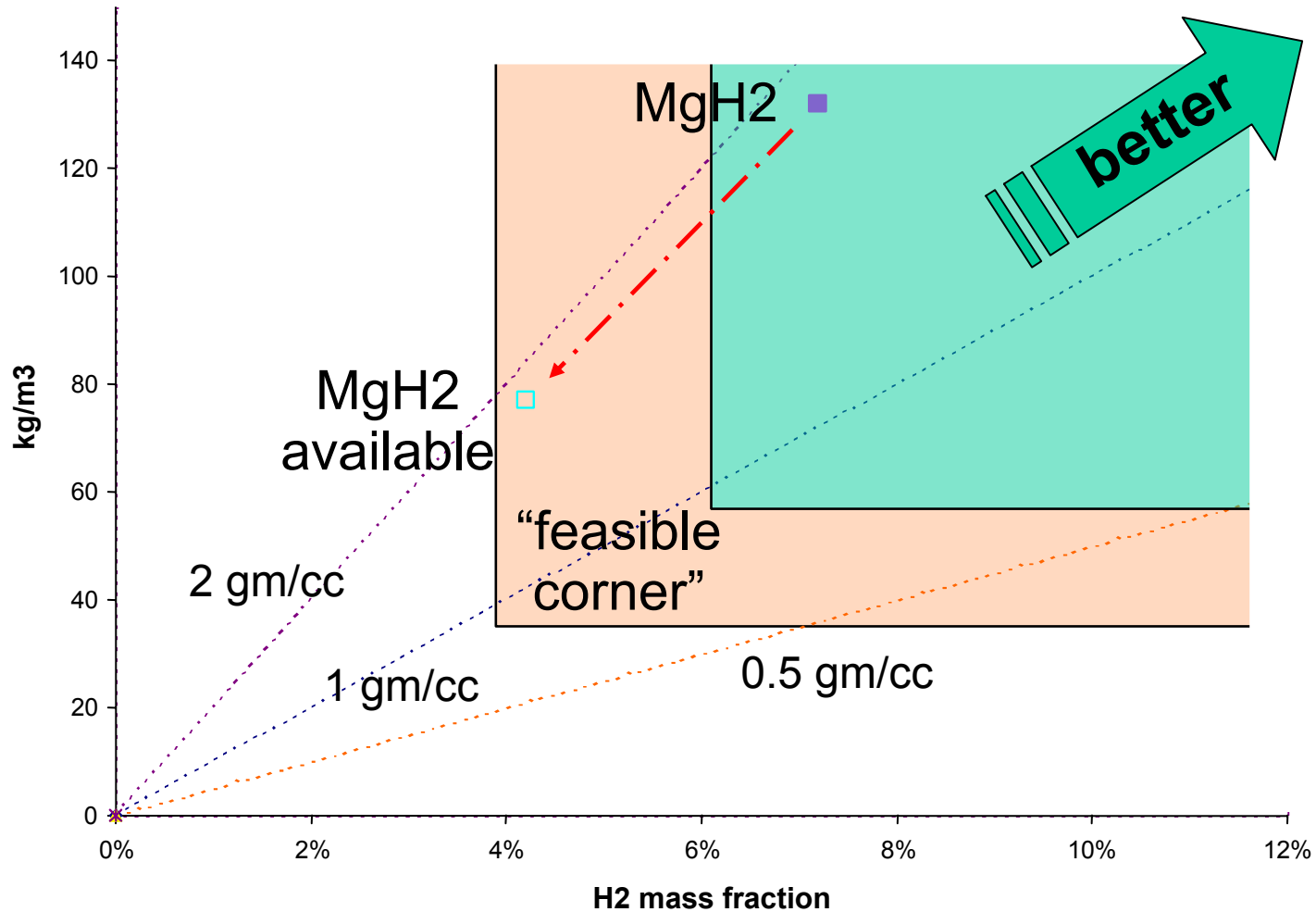

Mass and Volume Performance Targets for Hydrogen Storage Feasible by 2015 with Supercritical Fluid and Best Structures

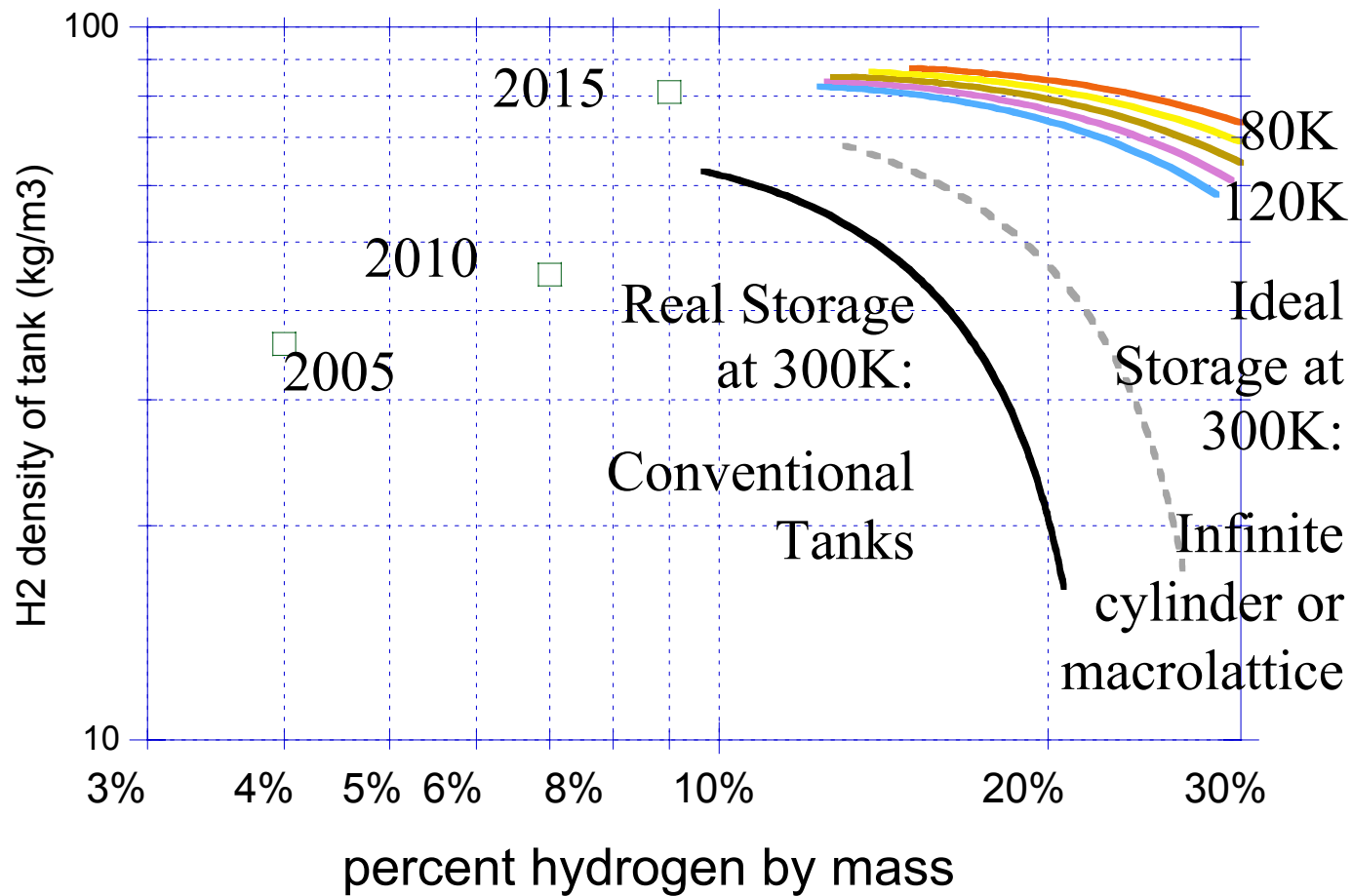

Technical Risk Analysis Dissects Potential Development Failure with a Fault Tree (arrows combine with logical 'and')



- Market Risk can drive Nominal Requirements into infeasibility (e.g. unattractive range)
- Automotive and Consumer Product Safety Testing methods can debug Unexpected Phenomena
- Semiconductor Quality Control methods (i.e. light bulbs, tires) solve for OK uncertainty

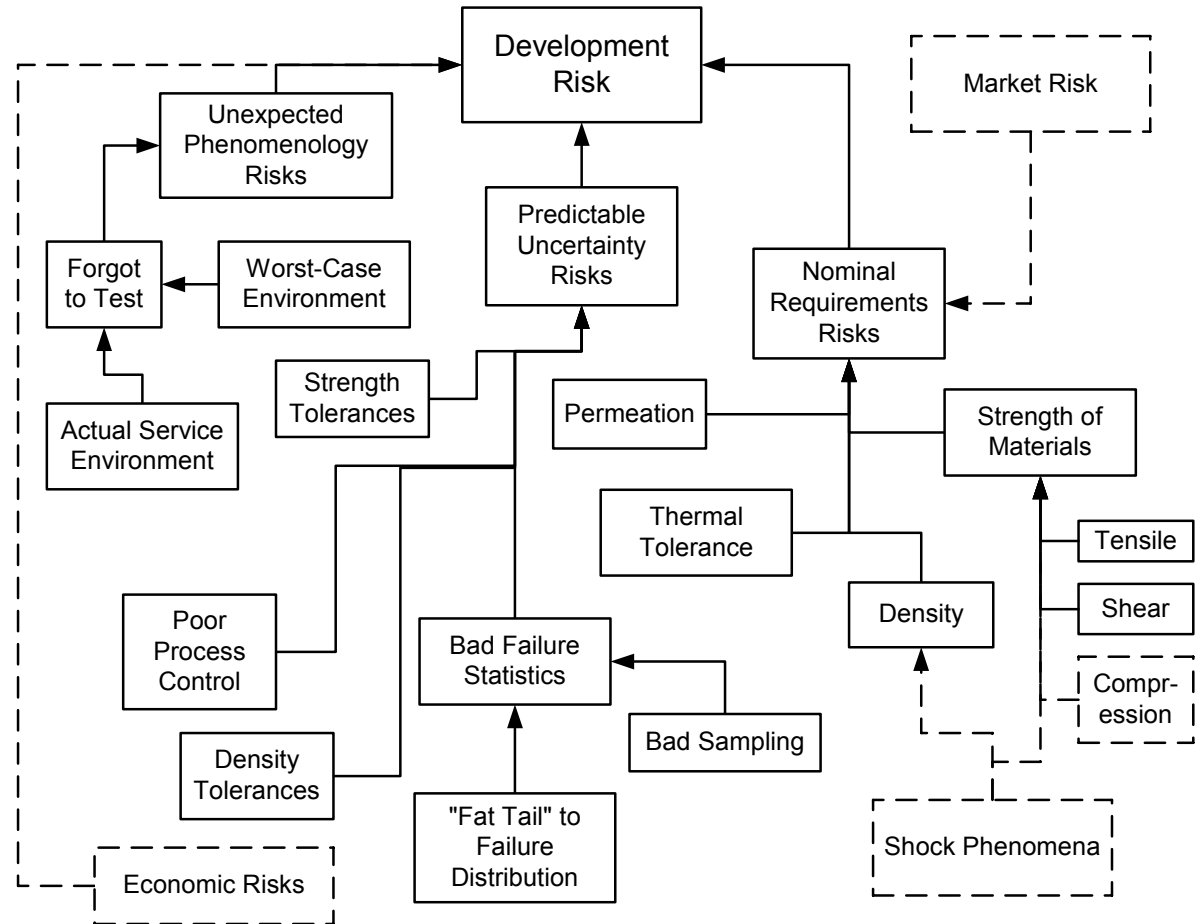

Shock Phenomena only relevant for fundamental safety gains

- Economic Risk – just \$0.06/sec on \$5M / 3 yrs.

Radical Containment

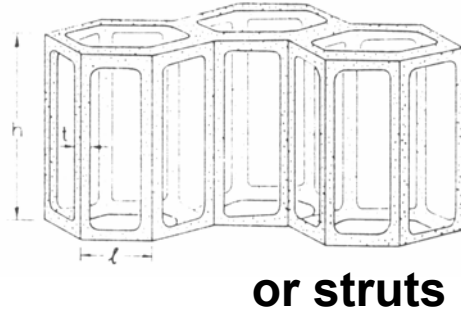
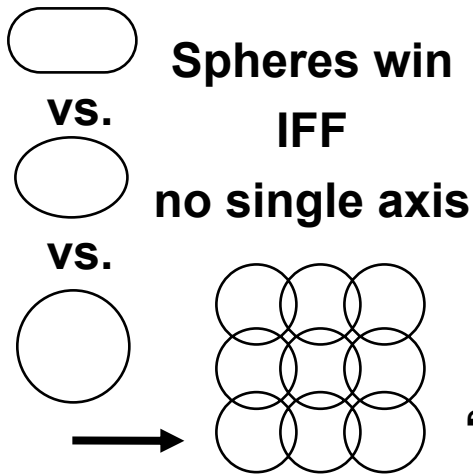

Hierarchical Structures

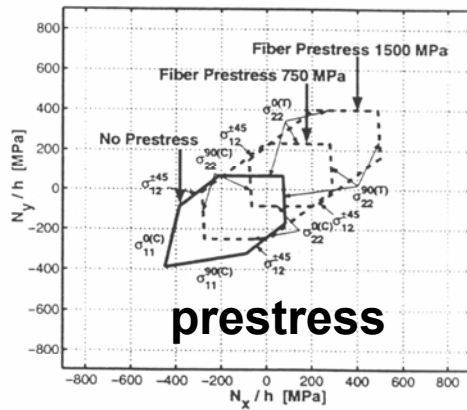
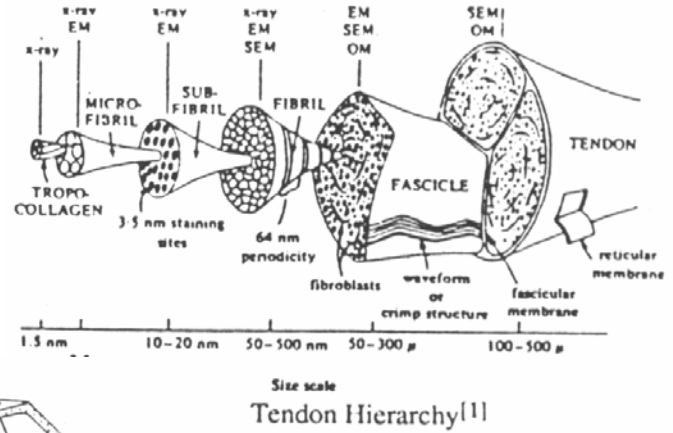
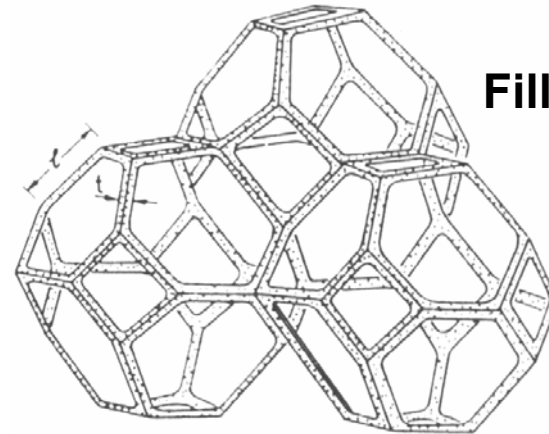
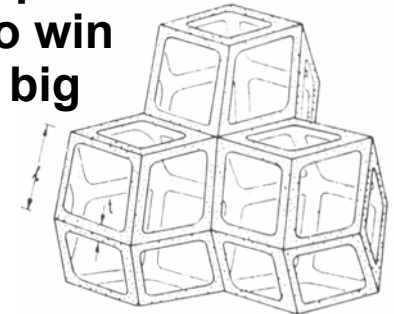

Figure 3: Effect of fiber prestress applied in all plies and cooling by -150°C on shape and position of initial damage envelopes for the 9-ply $(0/\pm 45/90/0)$, S-glass/epoxy laminate

Strength in two axes more than doubles mass performance implying flakes beat whiskers



Fill space to win big



≧ Many Figures of Merit (e.g. m/A)
But the best structures Maximize Volume and Mass Ratios
Struts' robustness beats Sprang ?

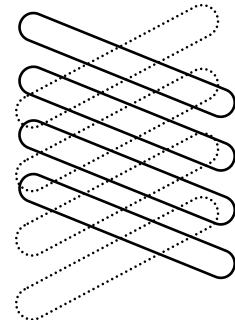



Thai vegetable

Vascular core

Functions as
fluid transport

Aids strength in
bending

Fibrous skin

Function is to
provide
strength in
bending

Also moisture
barrier

Bone is most familiar example of a structural tissue with additional transport and immune functions, with different adaptations and materials textures in core vs. skin



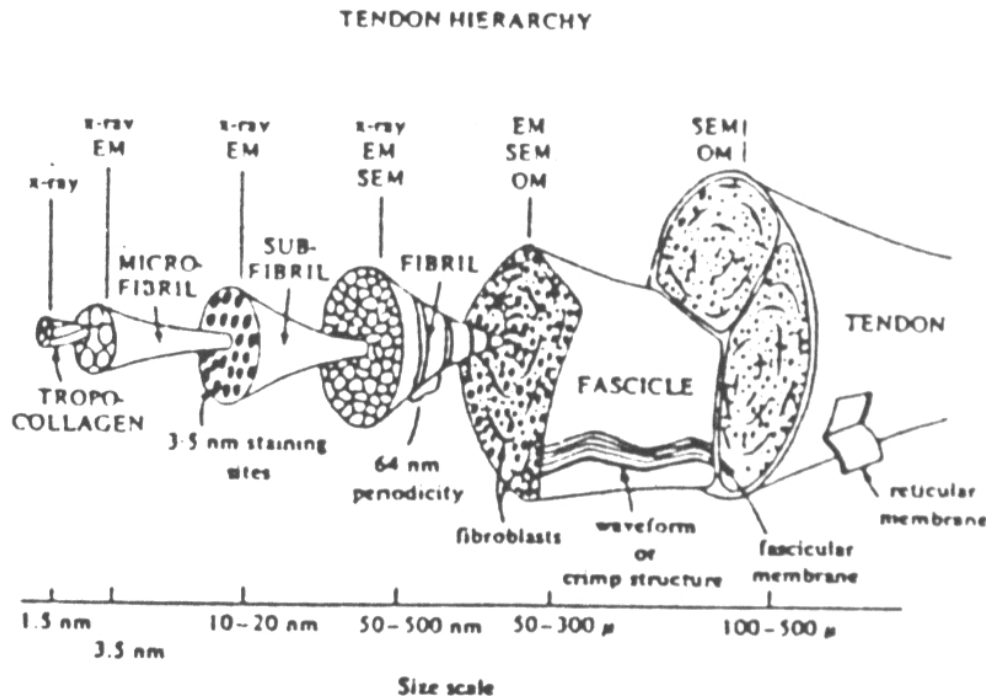

Figure 1. Tendon Hierarchy^[1]

1987 Conference Paper showed an organic Macrolattice with tensile load functionality

Literature on Heat Transfer Macrolattices ->

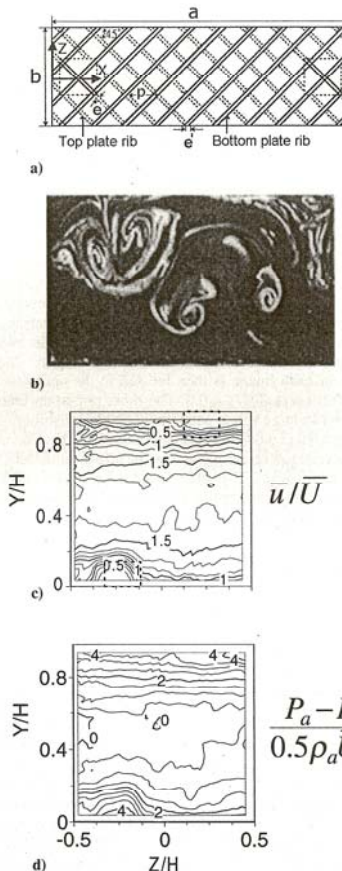

Fig. 22 Rib turbulator flow structure: a) schematic diagram of the rib turbulator test surfaces with 45-deg rib turbulators, $b = 411.0$ mm, $a = 1232.9$ mm, $p = 128.4$ mm, $e = 12.8$ mm, and $e' = 18.2$ mm with flow direction left to right; b) instantaneous flow visualization image illuminated in a spanwise-normal plane downstream of the rib turbulator test section at $X = 1462$ mm for $Re_H = 430$; c) time-averaged survey of local streamwise velocity in a spanwise-normal plane located just downstream of the rib turbulator test section at $X = 1235$ mm for $Re_H = 8 \times 10^3$; and d) time-averaged survey of local total pressure in a spanwise-normal plane located just downstream of the rib turbulator test section at $X = 1235$ mm for $Re_H = 8 \times 10^3$.



- . Up to 30% gain in volumetric efficiency***
- . Low technical risk but high development cost***
- . Underconstrained problem: many approaches***
- . Can't buy the components: learning is required***
- . Process research is needed to apply composites***
- . Mass production implies high tooling costs***
 - not a show stopper because solutions are scalable***
 - so minimize R+D cost via prototype scale and shape***

Macrolattice Replicates – Rediscovered in 2003



- Mass produce identical parts

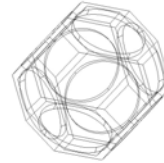

- Speed down the “Learning Curve”

Millions of parts for just
hundreds of vehicles !



- Statistical Qualification (large N)

- Many container geometries
- Collect data separately for

Each type of node, edge, face

- Metaphor = Architecture

- Not many domes or arches



compared to
‘endoskeletal’
structures built
routinely by
assembling
multi-use parts

Learning Curves

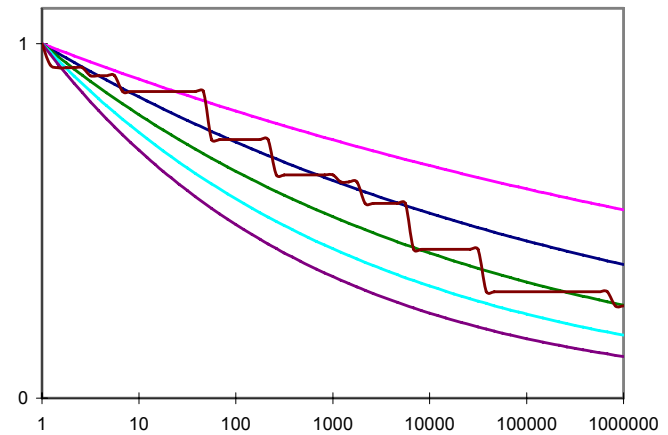

- A ‘vocabulary’ of geometries from a fixed lexicon of parts (more is richer)

Metaphors Derived from Diverse Disciplines



- **Architecture** - a 'vocabulary' of structural elements
 - (Successful 15 year regulatory transition to distributed-load designs)
- **Applied Mathematics**
 - **Differential Geometry** Curvature limits on composite assembly
 - **Group Theory** Generation and description of lattices
 - **Trajectory Optimization** Vehicle optimization with constraints
- **Aero/Astro**
 - **Composites** Topics shared with ME and Mat. Sci.
(Successful 35 years of experience getting the most from fiber winding)
 - **System Integration Methods** Subsystems Partitioning, mass accounting
- **Operations Research** Reliability Theory
- **Industrial Engineering** Manufacturing, process research
- **Design of Experiments** Minimize test program costs
- **Ballistics** Shock propagation and shrapnel
- **Crystallography** An obvious metaphor, some utility
- **Collision Kinetics** Understanding crash mechanics
- **CAM** Robot Assembly of replicants

Features of Macrolattices



- **Shape flexibility** almost arbitrary exterior dimensions
- **High volumetric efficiency** approaching 1.0 with a good skin
larger 'vocabularies' of replicate components can build concave
scavenge volume in odd 'corners' of vehicles otherwise unused
- **Crash-worthiness** potential to survive impact unruptured
orders of magnitude weaker in shear -> seal despite bending
control rupture location and size to dispose of fuel load safely
- **Thermal uniformity of contents** engineer heat conduction to gas
- **Rich statistics** saves direct cost of expensive fibers
lower "safety factor" can deliver guaranteed limits on $P\{\text{failure}\}$
based on many more samples from huge N , lower insurance too
- **Fault Tolerance** potential for redundancy to flatten $P\{\text{fail}\}$
- **Lower manufacturing cost** parallel processing yields higher dm/dt
- **Extreme safety** 'tanks' that bounce realistic, bumpers
- **Controlled rigidity** improve vehicle crash phenomena
- **Adaptable to flake composites** easier to upgrade with 2X gain
- **More thorough non-destructive testability** narrow vibration modes
- **Decoupled progress** improve skin, core, edges independently
- **Faster "Learning Curve"** depart from aerospace costs stuck in '85
actual learning curves are due to new methods (e.g hard disk drives)

'Shaping' the Best Replicant 'Vocabularies'



- **Joining replicated components allows many possible shapes**
 - **Reject customized components (e.g. Space Shuttle tiles)**
 - **Design for mass production and re-use across applications**
 - Process engineering -> parts, common CAD/CAM tooling -> applic'ns
 - Specializing for one application undermines statistical advantages
 - **Relax the assumption of replicated unit cells (made in 2002)**
 - Costly to transfer tensile loads across cuts in fiber, so join 'cells'
 - Struts can cross multiple cells, built for a small list of exact lengths
 - Or joined in log-n vocabulary of cell length multiples to minimize vocabulary size
 - **Select among lattice classes for crash safety**
 - Strength is not a noun, its a 3x3 2-tensor!
 - No valid reason to be too strong in shear
 - Good tanks can easily be stronger than their vehicle
 - Only need strength in 3 of 9 tensor elements to withstand stresses due to internal Pressure loads
- **Simplify – build only two of four classes of Space Group 'parts'**
 - **No vertices or cells belong in the built parts kit, just edges and faces**
 - **Translate into M.E.: a truss with no nodes, just links and skin tiles**
- **Solids Mechanics constrains the parts' geometry given a Group**
 - **Fraction of section area carries loads perpendicular to a virtual cut**

INTERNATIONAL TABLES
FOR
CRYSTALLOGRAPHY

Volume A
SPACE-GROUP SYMMETRY

Edited by
Theo Hahn

Crystallography Provides Exhaustive Enumeration Describing All Possible Symmetric Macrolattice Cores



$R\bar{3}$
No. 148
HEXAGONAL AXES

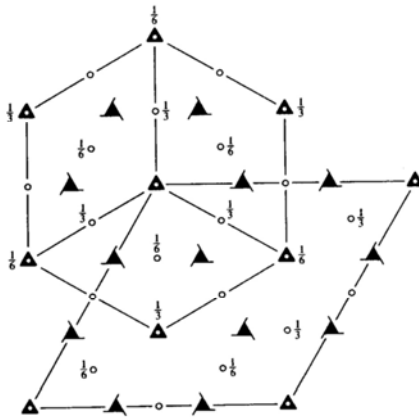

C_{3i}^2
 $R\bar{3}$

$\bar{3}$

Trigonal

Patterson symmetry $R\bar{3}$

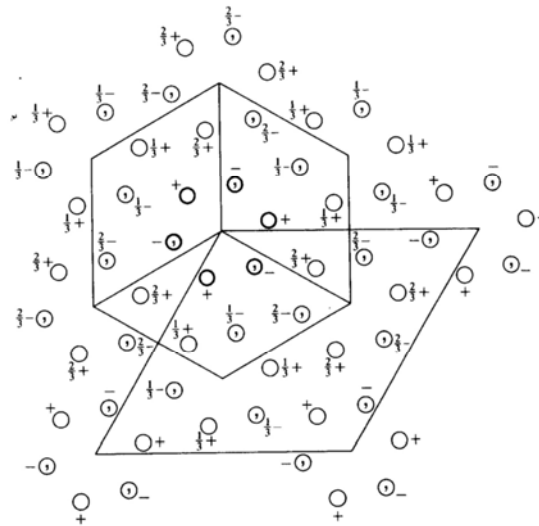

$Fm\bar{3}c$
No. 226

O_h^6
 $F4/m\bar{3}2/c$

$m\bar{3}m$

Cubic

Patterson symmetry $Fm\bar{3}m$

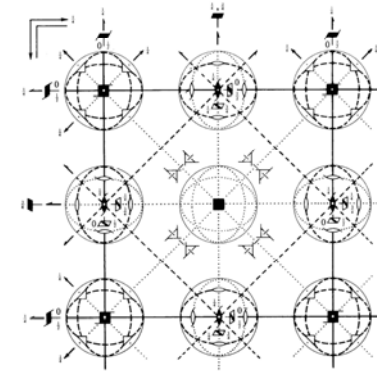

Upper left quadrant only

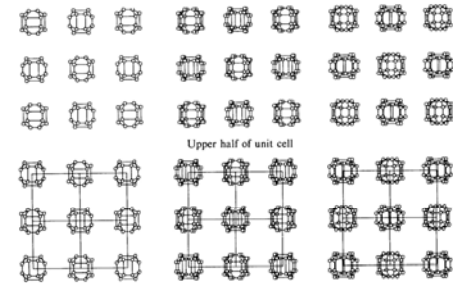

Upper half of unit cell

Lower half of unit cell

Origin at centre ($m\bar{3}$)

Space groups exhaust all possibilities for

Packing 3D space with identical, symmetric unit cells

Identifying which of the 230 Space Groups corresponds to a symmetric structure can be performed by locating axes of rotational and mirror symmetry, projected onto the mid-plane of the unit cell using these elegant diagrams (from Hahn '94 tables)

Replicates Taxonomy



- Consider Hydrogen Storage Subsystem components. Most are ancillaries, small in volume and mass, posing relatively slight technical risk.
- A unique component holds almost all of the hydrogen. Split this component into container and contents
- Contents include hydrogen, its impurities, and optionally a carrier (i.e. remainder of a hydride's constituents, a solvent for hydrogen, nanotubes, etc.), are generally presumed homogeneous, and have time-varying properties
- The container is the objective of this subproject. The container is designed to be a time-invariant solid, although it includes time-varying impurities and its geometry can change due to both the amount of its contents and external loads
- The container is deliberately structured to perform its job of retaining all phases of its contents (perhaps to different degrees) and of withstanding all anticipated structural loads
- That structure can have one or many regions that store contents. Only those structures with many such regions can be built from replicates
- The replicates can be random or ordered (with slight randomness due to their manufacture)
- Foams are the most familiar random replicates, but their mass and volume requirements are generally at least twice as large as ordered replicates that do the same job
- Two subprojects of the current LLNL effort are analogous to open and closed cell foams
- The total number of replicants N in an ordered container = $n_1 \times n_2 \times n_3$, where $n_1 \leq n_2 \leq n_3$ without loss of generality, and all n 's are integers > 0
- Ordered replicants pack space with all the possible symmetries of crystals' unit cells, yielding varying volumetric efficiencies between ~ 0.7 and 1.0 . The best come close to 1.0 .

Skin Requirements and Preliminary Design Issues



- **Load Transfer** (applies to tiles, edges, corners)
Differential pressure across skin must be transferred into struts
- **Surface Strain** (applies only to tiles)
Skin need not conduct any of differential pressure loads, but must expand at the same rate as the core macrolattice when pressure changes. In practice, locating the skin slightly outboard of the outermost unit cell's (dihedral mirror symmetric) boundary puts the skin in uniform in-plane tension directly proportional to differential pressure
Compliance of the skin must be chosen to match the strain in the core, so that the skin does not cycle between loose and tight and the outermost cells won't carry loads that fluctuate above and below identical stress
- **Struts beneath surface => constructability**
Low in-plane stress, high in-plane compliance permeation barrier need not be thick, but the structure supporting it needs considerable depth to transfer differential pressure loads
Five concepts so far appear adequate to develop into skin 'tiles': tensile parachutes that connect to four struts, wound tiles which add hoop stress, square stiff-in-bending tiles open to the interior, metal egg-crate structures with metal skin, and cast 'candelabra' of branching fiber
All of these concepts require depth to transfer differential pressure loads 'sideways', but too much depth runs into struts just inboard
- **Permeation Barrier – adequate cycle life in tiles and seams**
- **Mixed endoskeletal / exoskeletal variants carry high skin forces**

Limitations of Crystallography



- **Continuity of load paths**
 - Most of stress "flows along" fibers, can't stop 'abruptly'
 - Curvature limited by strength of matrix in shear
 - Can be thought of as additional continuity requirements on facets
- **Solid models not fully represented by points or lines**
 - If boundary representations could be correctly reduced to vectors, CAD would not need these richer descriptions to assemble 3D entities
- **Connection of 3D to 2D and 1D and 0D elements**
 - Demands strong intervention into the closed operations of a group
 - Possible to embed a partial lattice inside a ring group, but is it helpful?
- **Micro-to-Macro matching of solutions**
 - Know how to do this for atoms and metal lattices, not for 3D structures
- **Defect load path**
 - Much larger variety of defects in macrolattices than in regular crystals
- **Full FEM useful – computational experiments solve periodic BC's**
- **Probably obeys Physics (version of Group Theory) decomposition of Cartesian Tensors into irreducible form, using spherical harmonics**
- **Correlated failure modes – nothing similar in Materials Science (yet)**

Long-Range Order: 1st Manufacturable Macrolattice

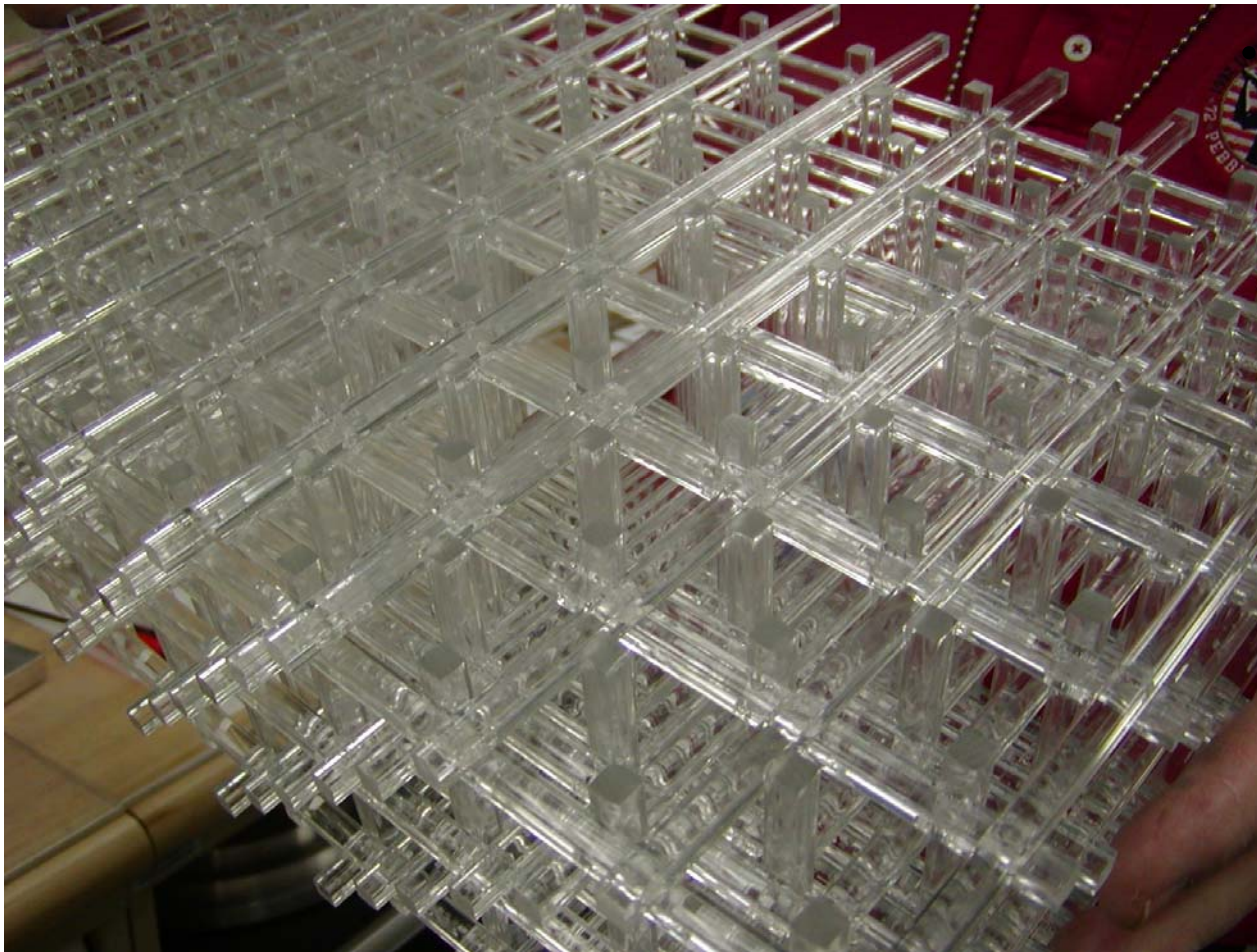

Appears cubic

- **Actually C3i**
Reduced Symmetry
Struts pass each other, avoid any nodes
- **Only 2 struts pass close to one another at any point (not 3)**
Weak glue bonds
'Stitched' together by robot bonder
Bond corridors

- **2004 model has correct volume fraction for best composite structure**

Area ratio 1/18 on each axis (or 1/6th struts by volume) was designed for 22,000 psi burst with uniaxial struts that are built to fail at 400,000 psi

Experimental Plan



- **Generation 0 = Functional Model** {designed to yield max learning/\$}
 - All components included {communicate concept by example}
 - Core carries pressure loads** {min effort 4x4x4 cells, 48 rods}
 - No 'cheating': loads due to pressure are only increased by slight compression in skin
 - Far from performance limits {safe operation and certifiably-safe viewing}
 - Correct illustration of core volumetric efficiency for the most likely vehicular 'tank' solution
 - Skin keeps gas (air) contained** {visible interior shows core, no H2 risks}
 - Not the way to build a skin with decent mass performance (no need for bending strength) !
 - Learn tooling, metrology, instrumentation {no intent to test to failure}
 - Planning for later generations requires debugging of tools and sensors**
 - After prototype's communication mission, attempt to deform it in shear
- **Generation 1 = Engineering Model** -> **prove FEM models with data**
 - Skin mass engineered comparable to core mass, still wrong materials
 - Minimal process research needed for molded skin faces -> min \$/copy
 - Build 7 copies, burst 5, measure strains and displacements, diagnose
- **Generation 2 = "Proof of Concept"** {no risks to feasibility remain}
 - Core fraction boosted above 80% of 'tank' mass with a cast metal skin
 - Tight tolerance on core-to-skin bond strength controls variance of P_{burst}
 - Demonstrate control and localization of failure, shear tolerance -> 10%

First Proto and Gen 0 Instrumentation

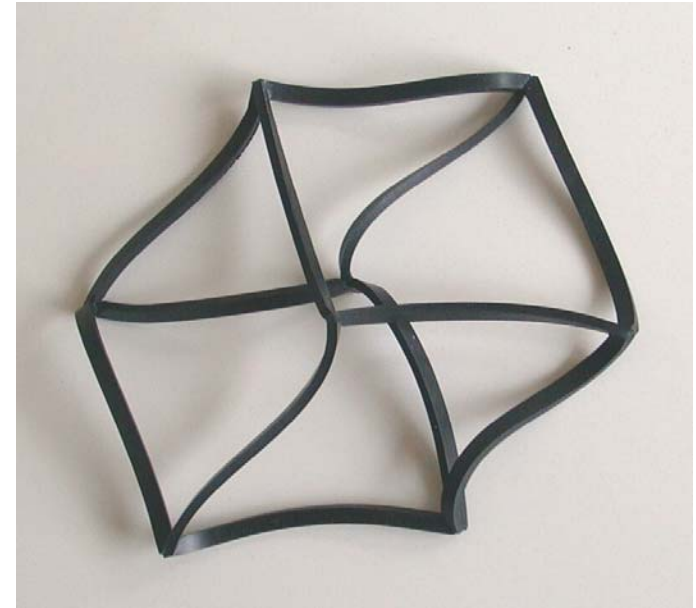
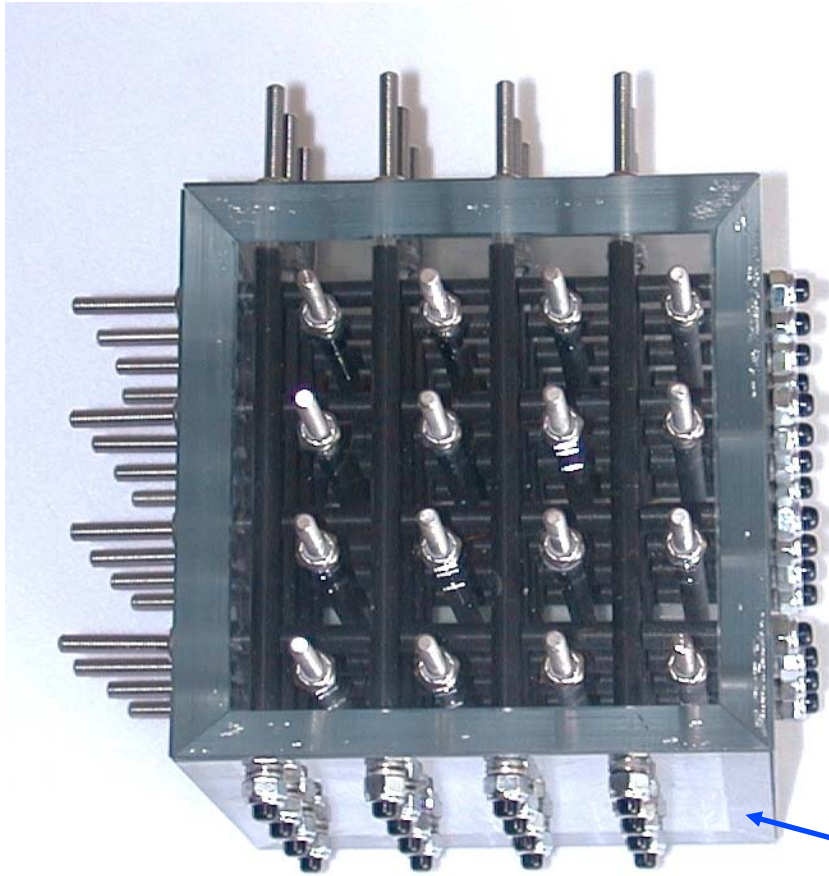

**Custom Neoprene Gasket
is bonded to join 12
edges at 8 corners**

Polycarbonate skin faces (6 identical)

**Instruments = torque wrenches, burst facility, pressure gages,
strain gages, capacitive distance sensors, lead weights**

Second Gen 0 Model with Functionality



- Seals added in second prototype
 - Details include piston-like o-ring seal between core rods and faces (rigid in bending) which can tolerate 0.035" expansion to mimic composite strain; and edge seal backing groove to tolerate very high proof pressures (to qualify proto at 5:1 SF)

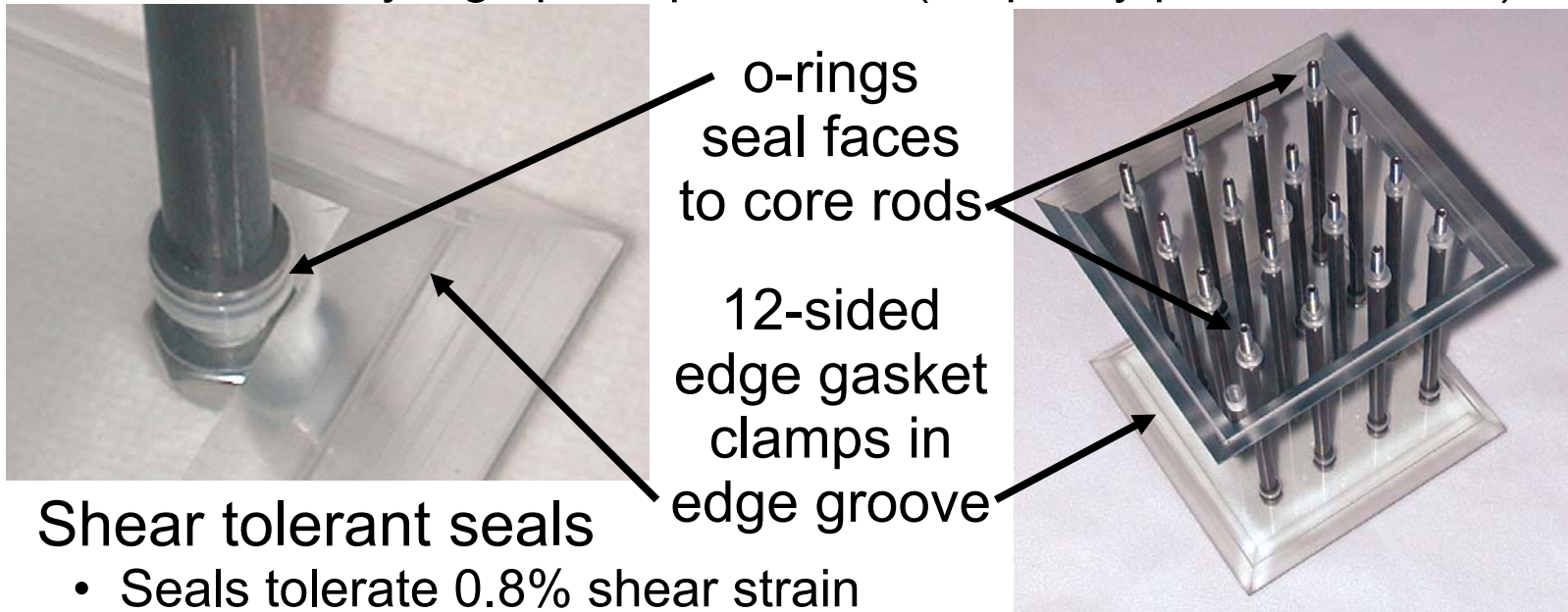

- Shear tolerant seals
 - Seals tolerate 0.8% shear strain
 - Much lower shear stiffness vs. axial stiffness (100:1) enables demo of major safety feature = content retention while warped



- Tubing replaces solid core rods to demo heat exchange

Preliminary Fabrication Sequence



- **Mass produce components :**
 - Tendons with high fraction of continuous fibers (pultrude?)
 - Skin Tiles – several variants build faces, edges, corners
- **Assemble+bond structural tiles onto ends of core tendons**
 - Must couple multi-GPA stresses in fibers through skin tiles
- **Stack rows of longest struts to form plane (I-beam section)**
- **Stack rows of intermediate-length struts to form plane**
- **Assemble mid-length atop longest plane to form 'waffle'**
- **Structural bond around wide lip of 'waffle' in compression**
- **Stack waffles in alignment tool for assembly of short axis**
- **Fixed automation final assembly (for large production runs)**
- **Dip coat assembly to prevent intrusion of molten plastic**
- **Final molding operation forms plastic liner outside lattice**
- **Qualification testing of finished lattice container**
 - Interior volume, delta volume at proof pressure, modes' $\omega+\delta$

Responses to Reviewers



- “Would like to see more actual testing and see it earlier in the program”
 - Already testing. Program schedule requested before risk analysis lead to triage of uncertainties. Actually its 3 projects + ~40 milestones.
- “Need to work with pressure vessel manufacturers” -> Since FY1993.
- “It is difficult to see how the 2015 or even the 2010 targets can be met”
 - Consider 6th Evaluation to Storage Question 3 = “Nearing 2010 goals for physical storage methods in many dimensions, a significant advance”. Supercritical storage is high confidence for all 2015 goals.
- “Compressed hydrogen is not the answer to onboard storage”
 - Work not limited to compressed, better containers benefit all contents.
- “There is need for more work on cost of compressed and liquid storage methods to declare victory. While these were downplayed in the NRC report, it is hard to argue with the idea that most FCVs will initially use one of these methods if cost can be reduced to an acceptable level.”
 - Materials costs already acceptable, mass producibility fixes the rest.
- “Future work on compressed/cryogenic tanks will focus on **novel approaches for cost reduction and conformability**. Advanced concepts for tanks such as heat dissipation in solid-state systems will also be explored” => Summary of FY2004 Reviewers Comments, on first page.

Future Work



- Remainder of FY 2005
 - Generation 0 prototype experimentation
 - Finish Generation 0 prototype construction**
 - Debug Generation 0 assembly and operation**
 - Decrease preload on prototype seals and measure deflections at edge gaps and on core rods vs. Pressure**
 - Replace half the fasteners with Belleville washers to establish strain mimicry, measure face+shear compliance**
 - Select precision displacement and strain sensors
 - Generation 1 preliminary design: solid models of skin
- FY 2006:
 - Generation 1 design, build, instrument, burst 5 of 8
 - Generation 2 scope definition: processes and safety
- Thermal Transport via Macrolattices
- Return to Theory {given funding and interest}



The next 3 slides provide
background information

Conventional 'Tanks'



- Nomenclature: Type I = all metal, Type II = composite wrapped cylinder, Type III = composite wrapped with metal liner (limits max strain), Type IV = composite wrapped over plastic liner [metal bosses]
- Figure of Merit is $P_b V / W$ (burst pressure * volume / weight, inches)
 - » Independent of choice of contents or “Safety Factor” = $P_{burst} / P_{max_oper'g}$
 - » Independent of scale given ability to fabricate and operate at same stress
 - » In practise, minimum gage (thickness) on liner and composite layers precludes scaling designs up or down beyond an order of magnitude of ~1 m
- Idealized cases are infinite cylinder and isotropic sphere, else lower $P_b V / W$
- Radius of curvature implies tensile stresses to balance differential P
 - » Becomes dimensionless constrain on radius over wall thickness $R/t < \sigma/P$
 - » Produces ideal result $P_b V / W = 1/3 \sigma/P$, Good end dome design costs ~20%
- Volumetric Efficiency is fraction of volume actually occupied by container
 - » Cylindrical tanks much worse than their 72% ideal (infinite length) case when occupying rectangular cross sections whose side lengths are not integer ratios
 - » Closed cell (geometric duals of macrolattices) recover this non-integer loss %

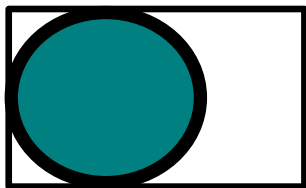

44%

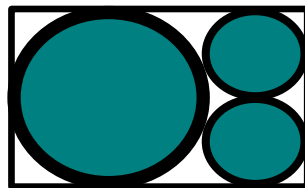

66%

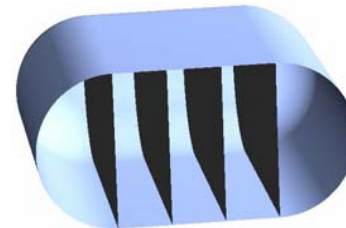

74%

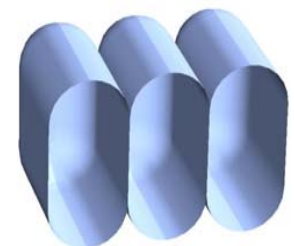

75%

Statistical Research (suspended since 2003)



- Actual Failure Data collected from assembly failure forces

The first installment of structural testing wherein a nearly identical collection of samples is broken

Diameter	N	material	form	Epoxy	Shear Strength
0.840"	1	composite	tube	Vendor 1	200 psi
0.450"	4	composite	rings	Vendor 1	460-870 psi
0.335"	3	Mg	discs	Vendor 2	880-1025 psi
0.335"	5	Mg	discs	Vendor 1	380-670 psi

- Sample Size 'identifies' Weibull Distribution

Weibull distribution

$$P(\sigma) = 1 - e^{-(\sigma/\sigma_c)^m}$$

The other "extreme value" distribution (vs. Gaussian) correct in the limit of the minimum of a large series of positive random values

- Risk of 'suppressed' failure modes with higher variance is neglected in current safety standards – not good enough for thousands in service!

$$p(\sigma) = \partial P / \partial \sigma$$

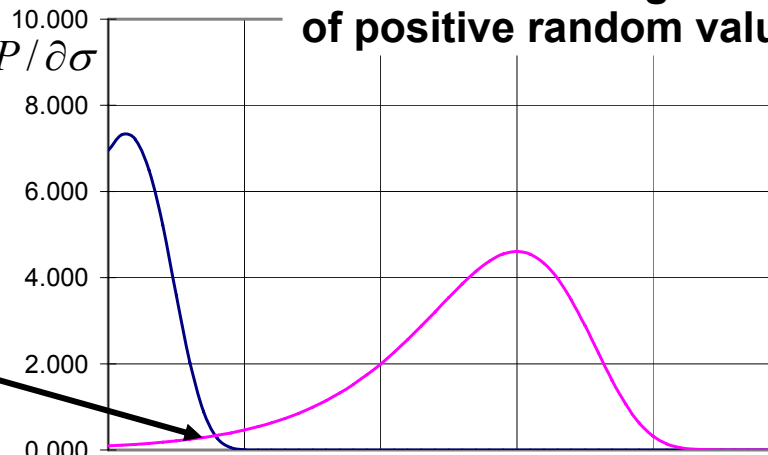

Overlap of $1/m=.05$ and $1/m=.08$ with "safety factor" of 1.3

- Recommend insurance requirements, European-required batch testing**

Less-Advantageous Replicants – 2004 Update



- Initially thought hexagonal faces of octahedral unit cell would be easiest to produce ->
- Discovered that curvature at corners of closed-trajectory faces is locus of excessive shear stresses that would fail matrix

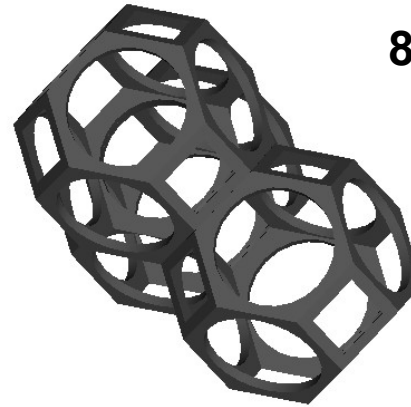

8 'wound' faces (nearly rings) can assemble to fill space

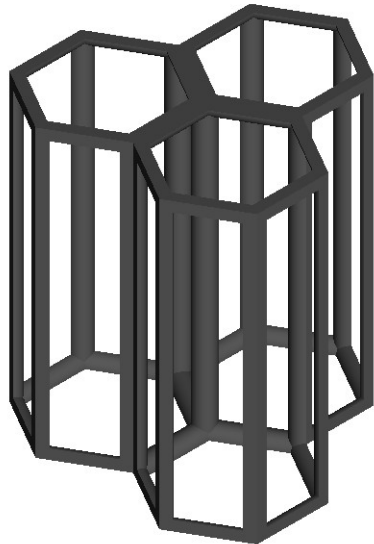
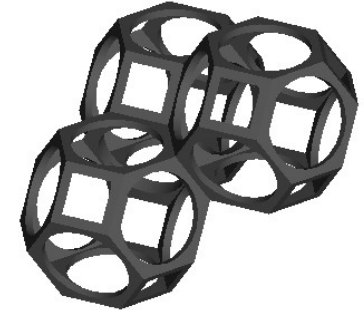

- Problems with radii of curvature are avoided by trusses whose replicated fiber struts **don't cross**

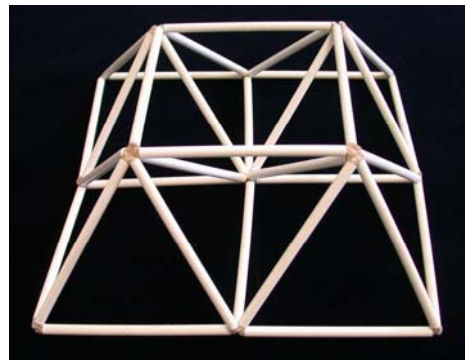

- Fuller's "Octet Truss" is strong in shear, which is no longer considered to be **safer in collisions**

- Solid modeling of replicants is non-trivial, hexagonal-closed-packed cell was easiest to render in 2003, builds slabs with skins

- Cubic is best for strong biaxial composites

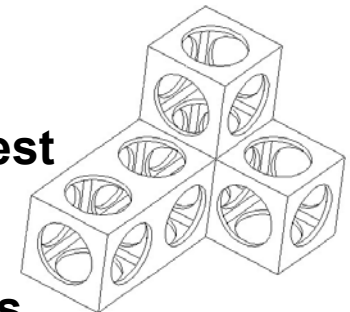

Publications and Presentations



- Poster and various models presented at the 2004 DOE Hydrogen Program Review
- Tech Team Meeting in September 2003 received part of a presentation delivered by teleconference with DOE headquarters and USCAR offices {audio from LLNL, viewgraphs delivered live by Salvador Aceves in Detroit}
- APS March 2005 Meeting in Los Angeles delivered 25 minute presentation using 44 pages of illustrations, followed by 10 minutes of questions, in front of an audience of ~135 Physicists. About 40% of this audience considered themselves theorists. This presentation has been requested in pdf format for online distribution via the APS website.



The most significant hydrogen hazard associated with this project is:

- Gigajoules of chemical energy released in the chaos of a vehicle crash
- Benchmark is 1 gigajoule = 278 kw-hr (lower-heating value) of 8.33 kg of hydrogen stored aboard one SUV
- Chemical energy sufficient to drive 300 miles dwarfs the mechanical energy in compressed fluids (exergy difference between stored and released states) or in strained solids (several megajoules of 'spring' energy are stored in a 10,000 psi pressure vessel)
- Roughly 5% of motor vehicle accidents result in a fire, all of these penetrate fuel storage, and these accidents are much more lethal (NTSB expert 2002)



Our Approach to deal with this hazard is:

- **Develop containers able to keep their contents inside despite significant impact and deformation**
- **Develop failure localization features that fail first when hydrogen pressure increases due to a crash**
- **Demonstrate fast disposal through nozzles that mix released hydrogen with surrounding air to concentrations below the explosive and flammable limits without the possibility of combustion**
- **Avoid the possibility of combustion using the temperature drop of sonic nozzles and flow velocities above the flame speed of hydrogen+air**
- **Build these nozzles in a slit-shaped form that can be realized in the post-rupture shape of a failure localization feature**
- **Demonstrate slow disposal through catalytic venting**
- **Convince those capable of volunteering for regulatory activities to re-word ISO TC197 so that hydrogen released within a container subassembly and mixed with air below the ignition limit or converted to water vapor is considered safe**

Possible Major Improvements in Safety

- *Benign Shrapnel – observed, but not measured*
 - *Several different failure mechanisms turn tanks to dust*
 - *LLNL knows how to calculate penetration, stop shrapnel in < 0.05”*
- *Engineered Disintegration – pick the failure locus*
- *Ignition-Proof gH₂ Venting via Sonic Disposer Nozzle*
- *Fire Avoidance – autonomous + Bluetooth*
 - *Secure wireless links are ready for fire departments to command*
- *Multiple Containment – already developing*
 - *Add catalytic venting, acceptability of gH₂O needs regulatory reform!*
 - *Eliminate the of risk of cryptic (no visible evidence) damage*
- *Scattering Theory for Automobiles*
 - *NTSB has not been collecting the right data (yet):*
 - » ***Fatalities but no shrapnel from ~300 crashed of 60,000 NGVs***
 - *Amusing and informative demolition videos show 'tanks' outlast cars*