

Integration of a Structural Water Gas Shift Catalyst with a Vanadium Alloy Hydrogen Transport Device

Tom Barton - Western Research Institute
Morris Argyle – University of Wyoming

tbarton@uwo.edu

7/13/08

Project ID #
PD42

Overview

Timeline

- Start - 7/1/05
- End – 12/31/08
- 75% complete

Budget

- Total project funding
 - \$1,445,427 DOE share
 - \$361,357 Contractor share
- Expenditure as of 3/31/08
 - \$691,350
 - In kind \$131,612

Barriers

- Water gas shift capital costs for IGCC
- Hydrogen transport membrane cost

Collaborators

- University of Wyoming
- Chart Energy and Chemicals
- REB Research and Consulting
- USDoE Ames Laboratory

Objectives

2006

- **Develop a structural water gas shift catalyst capable of withstanding compressive forces.**
- **Develop vanadium alloy hydrogen separation membranes for fabrication of devices by brazing.**

2007

- **Integrate the WGS catalyst and metallic membranes into a device and test under gasifier conditions.**

2008

- **Build a modular WGS/membrane integrated device capable of producing 10,000 l/day hydrogen from coal derived syngas.**

Approach

- **Task 1 Water Gas Shift Catalyst (80%)**
 - Alumina and ceria
 - Monoliths
- **Task 2 Scale Up Integrated Device (75%)**
 - Chart Energy and Chemicals
 - REB Research and Consulting
- **Task 3 Gasifier Testing (25%)**
 - Fluidized Bed Coal gasifier
- **Task 4 Economics (0%)**
 - Subcontract to University of Wyoming

Results

- **Task 1 Structural Water Gas Shift Catalyst**
 - Focus of the chemistry of the water gas shift catalyst has been on Fe-Al-Cr-Cu-Ce system
 - Catalysts have been tested by impregnation into porous mullite substrates
 - Highest activity and stability has been shown for 75Fe-15Al-8Cr-2Cu
 - Small additions of CeO₂ look promising

Appropriate amounts of added alumina (Al_2O_3) increase WGS rate and stability

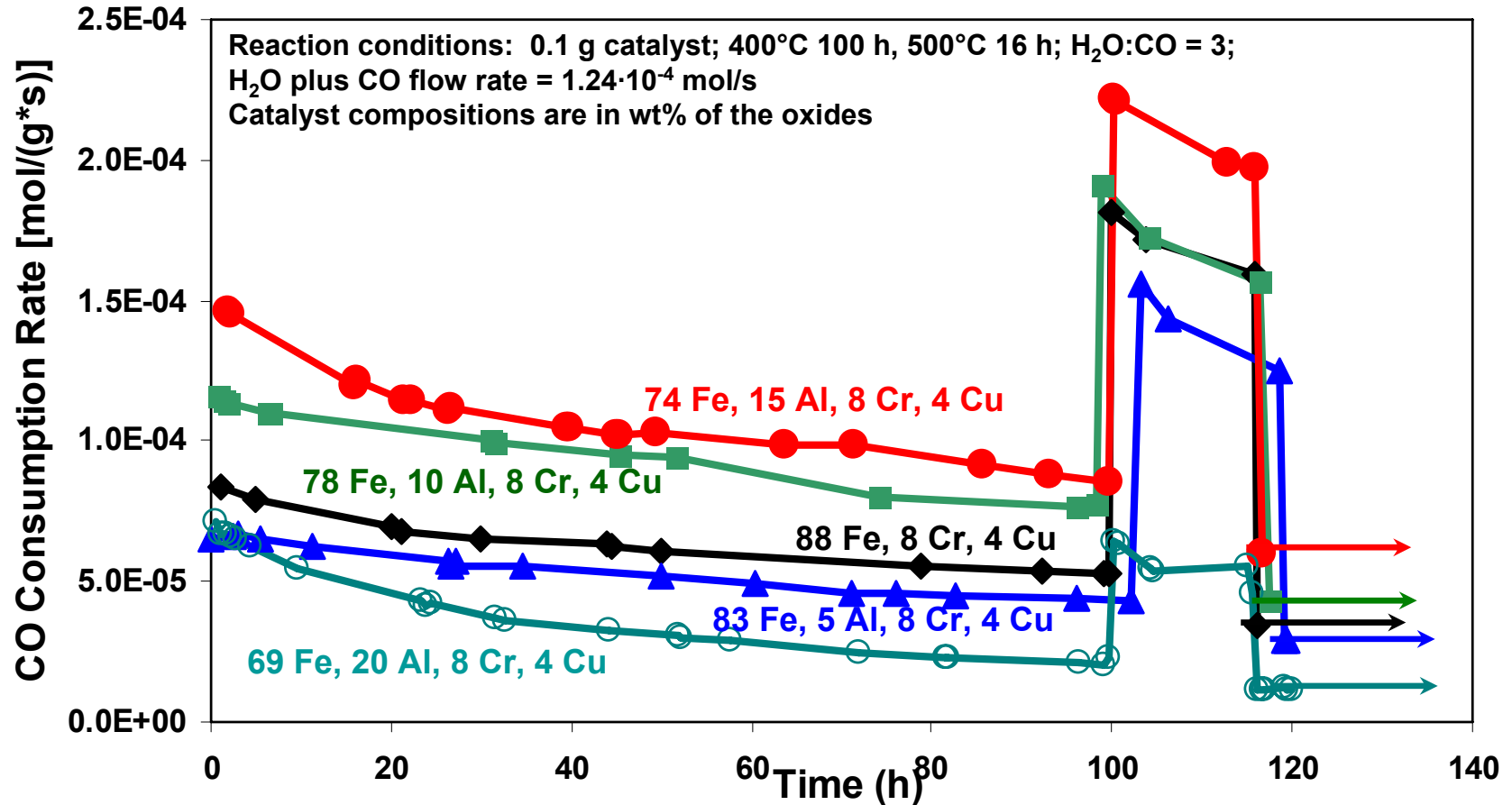

- 15 wt% alumina addition is optimum, but 10 wt% is close
- 5 wt% and 20 wt% alumina addition are detrimental relative to base catalyst with no alumina

Ceria enhances WGS rate and stability at lower concentrations than Al_2O_3

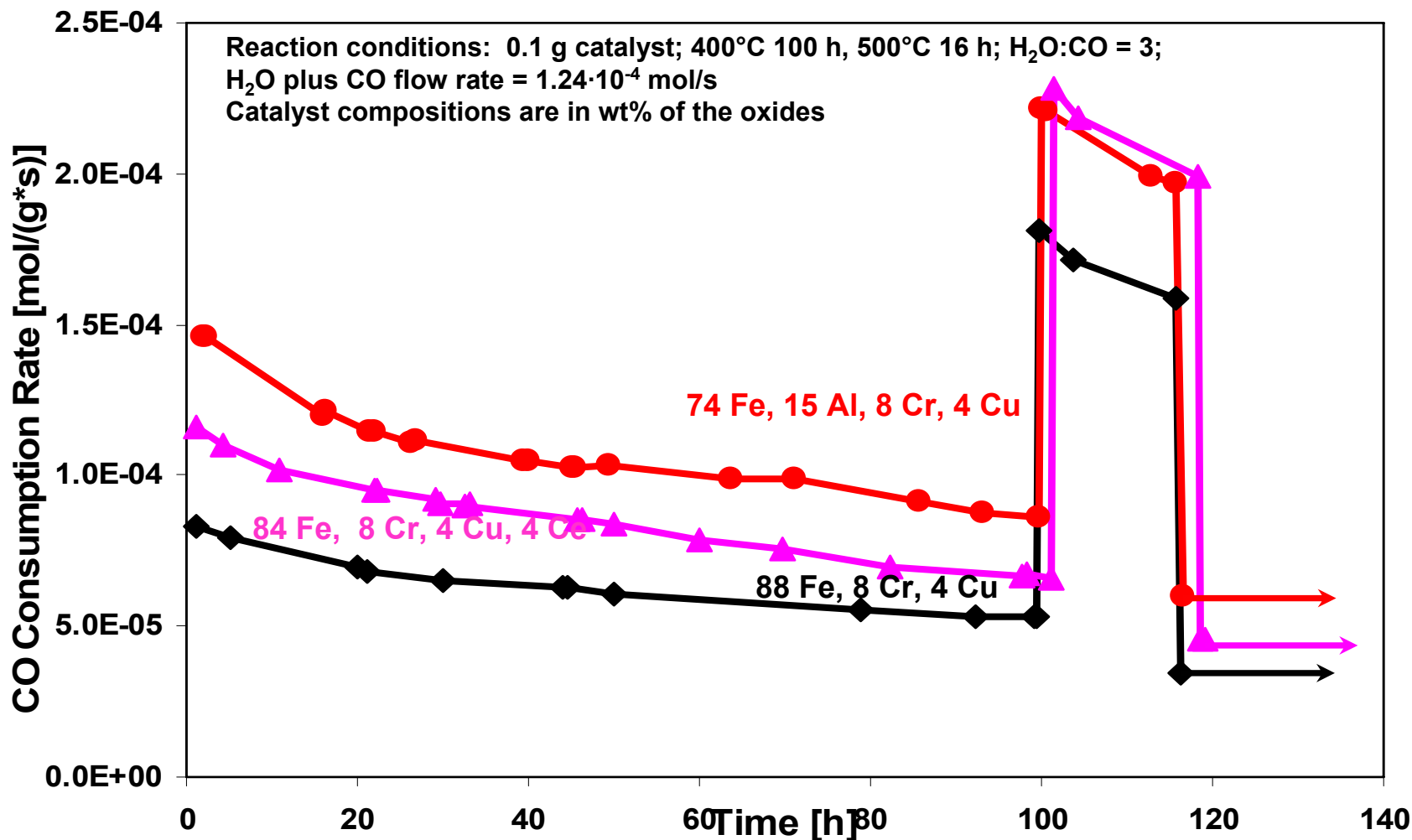

- Small amounts of added alumina or ceria produce higher rates and more thermally stable high temperature water gas shift catalysts compared to conventional iron oxide/chromia/copper

Ceria WGS catalysts are sensitive to preparation conditions

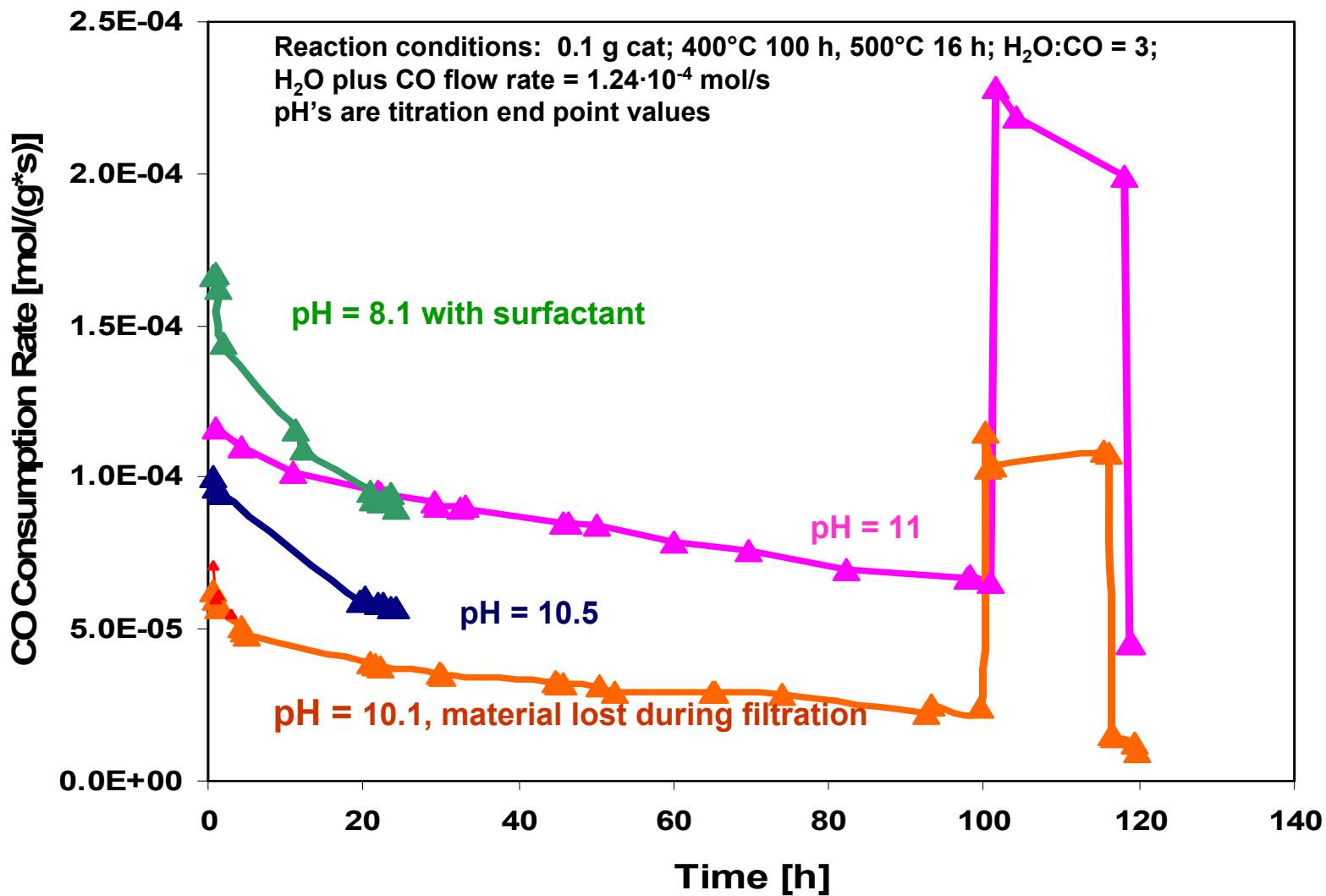

- Lower pH with added surfactant enhance initial rate and stability

Ceria WGS catalysts are sensitive to thermal pretreatment conditions

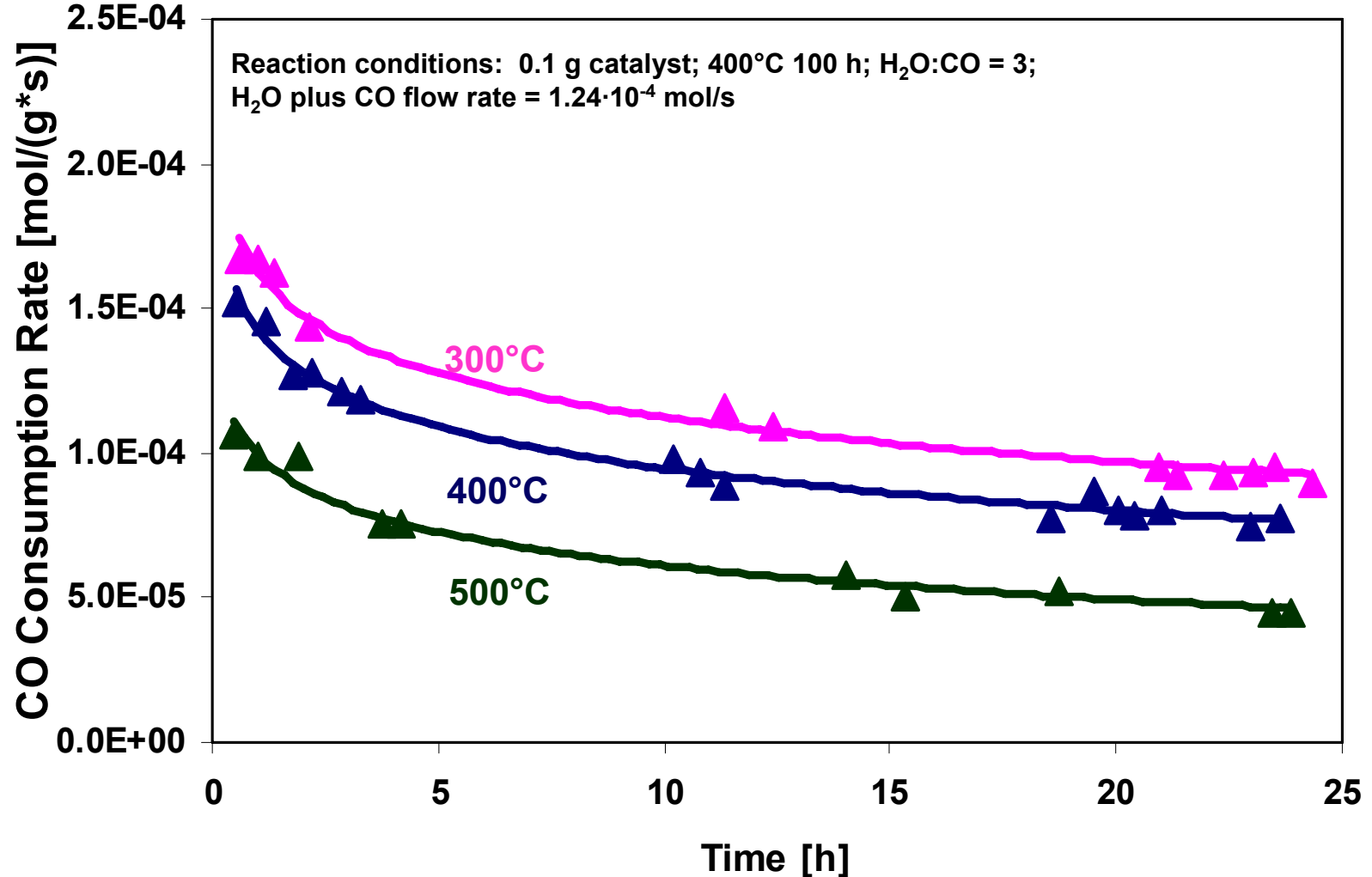

- Thermal pretreatment in air (calcination) stabilizes catalyst prior to reduction under reaction conditions
- Calcination T > 300°C, however, reduces surface area and rate

WGS Catalyst Next Step: Incorporate catalysts into appropriate ceramics for reactors

- Catalysts with alumina and ceria additives were chosen for study because they are components of and compatible with ceramics
- Future catalysts will be deposited on ceramic monoliths from commercial sources
- Ceria containing catalysts are proposed; however, deposition difficulties or temperature requirements may necessitate use of the optimum alumina-containing catalyst

Ceramic honeycomb monoliths will be impregnated with WGS catalyst

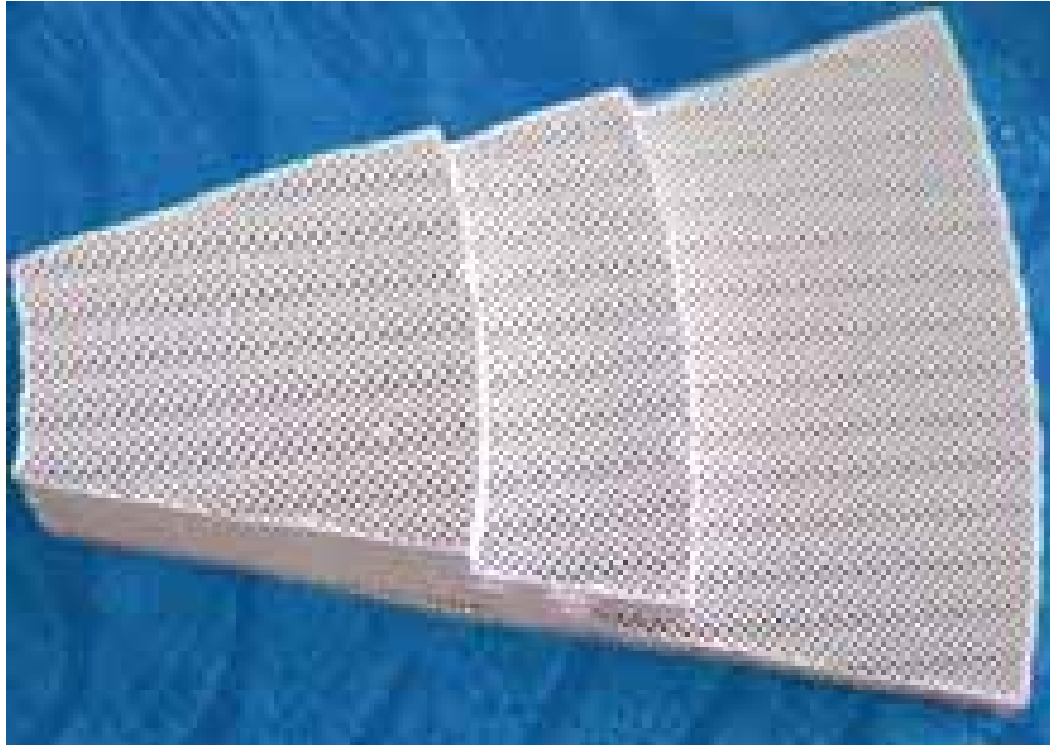

Catalyst bed will have fixed hydrodynamics and be easy to replace

- **Task 2 Scale Up Integrated Device #1**

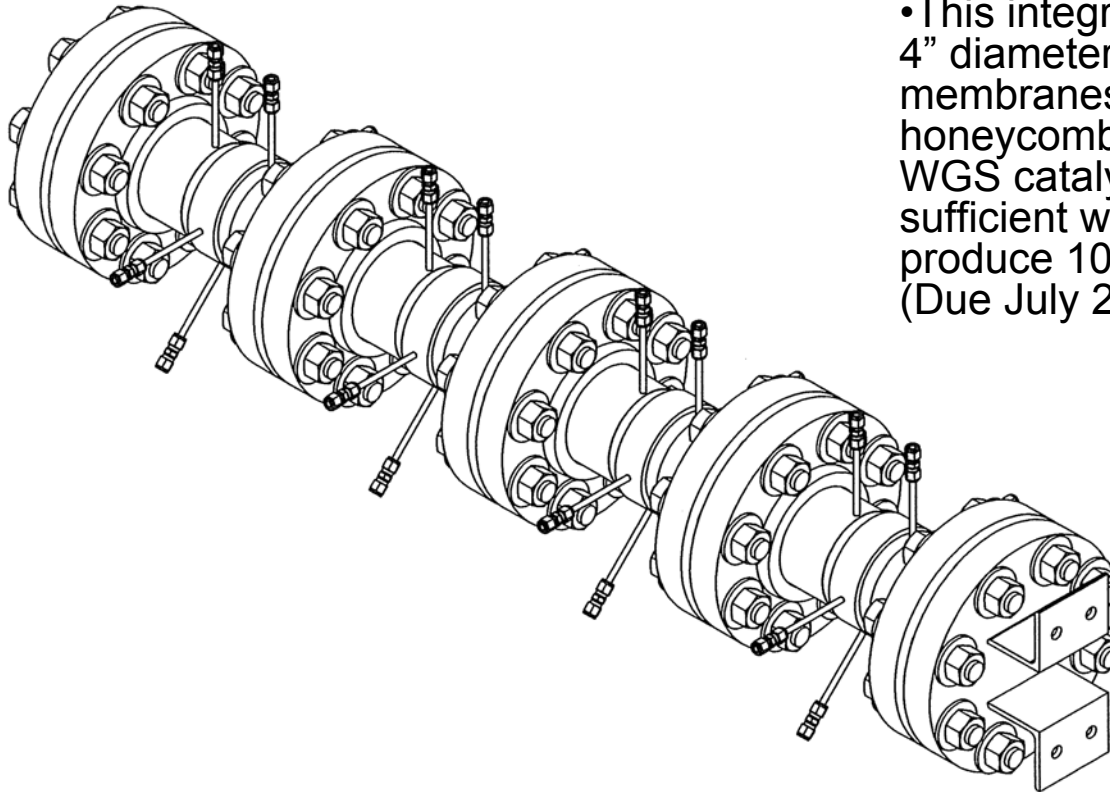

- This integrated device has eight 4" diameter vanadium alloy membranes sandwiched with honeycomb ceramic supported WGS catalyst to provide sufficient working area to produce 10,000 l/day hydrogen. (Due July 2008)



Energy & Chemicals, Inc.

Chart Heat Exchange Reactor

•Chart Energy and Chemicals' expertise with heat exchangers has led them to develop ShimTec technology which uses thin layered structures to maximize surface area to volume.



Chart ShimTec Technology

- The ShimTec approach could be the answer to the application of metallic membranes for hydrogen separation in very large scale. Structural ceramic catalysts for water gas shift would be incorporated into the assembly. A 10x or 100x integrated device might be the next step in vanadium membrane advancement using this approach.



Task 2 Scale Up Integrated Device #2

- The second scale up unit is based on a “disc and doughnut” design produced by R. Buxbaum of REB Research and Consulting. In this design, the vanadium alloy membranes are joined in pairs into a structural component capable of withstanding differential pressure. Under a subcontract from WRI, Dr. Buxbaum is preparing an integrated two membrane unit to contain the monolithic catalyst component. Scale up of this stackable unit appears straight forward. The two membrane unit is expected in July 2008.

Disc and doughnut design of a hydrogen separation system



Disc and Doughnut Schematic

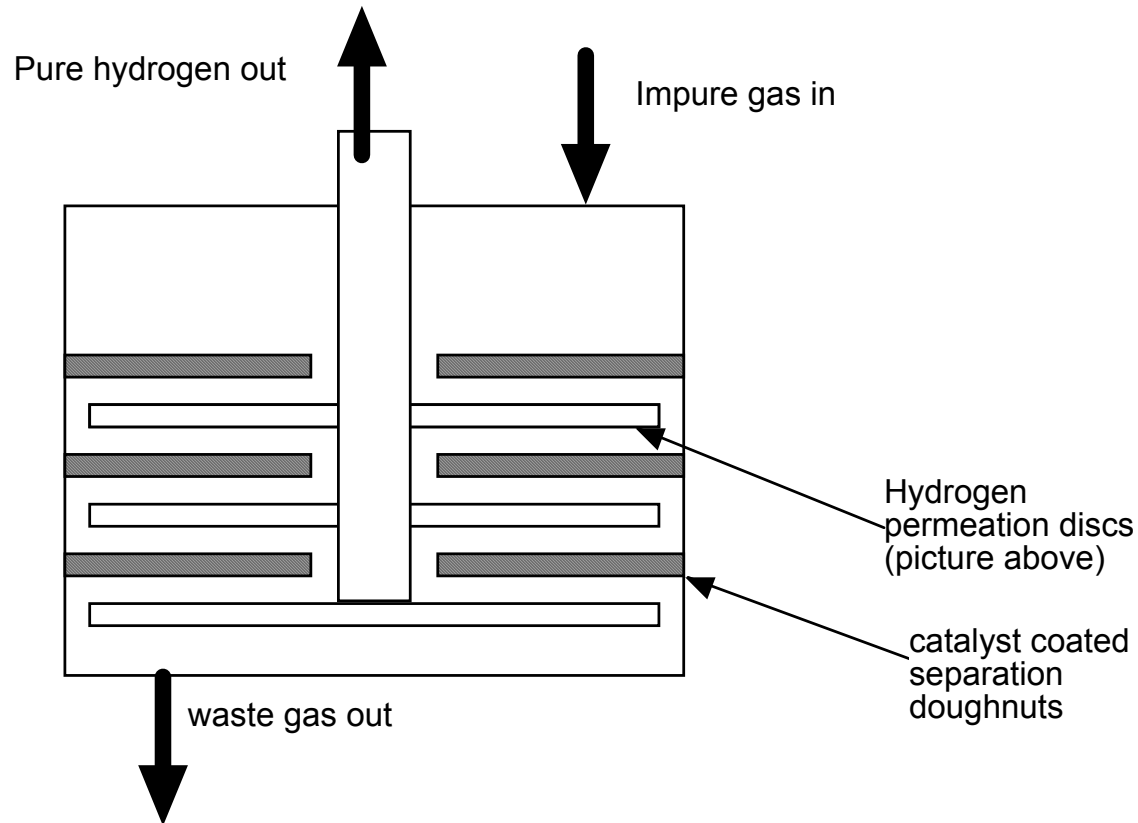

- **Task 3 Gasifier Testing of WGS-Vanadium**
 - **WRI operates a steam/oxygen blown 7 inch fluidized bed coal gasifier using Powder River Basin coals.**
 - **Temperature control allows some hydrogen/carbon monoxide ratio adjustment (40/60 to 60/40).**
 - **A 90 to 120 scfh syngas slipstream can be cleaned for particulates, condensate, sulfur and mercury.**
 - **Secondary vessel is heated and compressed for testing catalysts, membranes or integrated system.**
 - **The operational temperature is 400 - 450°C, the testing pressure is 115 psia.**
 - **Hydrogen sulfide concentration will be tested from <5 ppm to 25 ppm.**

Future Work

- **Commercialization of the water gas shift catalyst monolith will be pursued with the assistance of a catalyst manufacturer.**
- **Successful testing of the two scaled integrated devices will be followed by design of a 10x assembly based on the economic and performance data for testing under coal gasification conditions.**

Project Summary

Approach: The key to a commercially scaled device that integrates metallic hydrogen transport membranes and water gas shift catalyst will be a catalyst with high compressive strength and no friability and a practical low cost method to attach the membranes to structural alloys.

Conclusions: The ceramic catalysts developed are superior to commercially available WGS materials with respect to survival in a pressurized device. Two different viable integrated device designs using vanadium membranes are under fabrication that should meet scalability issues and performance criteria.

Future Work: Successful testing of the integrated devices in coal derived synthesis gas will be followed by scale up by 10x. Commercialization of the WGS catalyst monolith will be pursued.