

MASS-PRODUCTION COST ESTIMATION OF AUTOMOTIVE FUEL CELL SYSTEMS

DOE H₂ PROGRAM REVIEW

**BRIAN JAMES &
JEFF KALINOSKI**



MAY 21, 2009



3601 WILSON BLVD
SUITE 650
ARLINGTON, VA 22201
703.243.3383

FC_30_James

Overview

Timeline

- Base Period: Feb '06 to Jan '08
 - 100% complete
- Option Year 1: Feb '08 to Jan '09
 - 100% complete
- Option Year 2: Feb '09 to Jan '10
 - 10% complete

Budget

- Total Project Funding:
 - \$407k (2 year base period)
 - \$160k (option year 1)
 - \$166k (option year 2)
 - \$150k (turbocompressor task)
- Funding corresponding to FY 2009
 - \$251k

Barriers

- Manufacturing costs
- Materials costs (particularly precious metal catalysts)

DOE Cost Targets

Characteristic	Units	2008	2010	2015
Stack Cost	\$/kW _{e (net)}	-	\$25	\$15
System Cost	\$/kW _{e (net)}	-	\$45	\$30

Collaborations

- Extensive interaction with industry/researchers to solicit design & manufacturing metrics as input to cost analysis.

Objectives

1. Identify the lowest cost system design and manufacturing methods for an 80 kW_e direct-H₂ automotive PEMFC system based on 3 technology levels:

- 2008 status technology
- 2010 projected technology
- 2015 projected technology

2. Determine costs for these 3 tech level systems at 5 production rates:

- 1,000 vehicles/year
- 30,000 vehicles/year
- 80,000 vehicles/year
- 130,000 vehicles/year
- 500,000 vehicles/year

3. Analyze, quantify & document impact of system performance on cost

- Use cost results to guide future component development

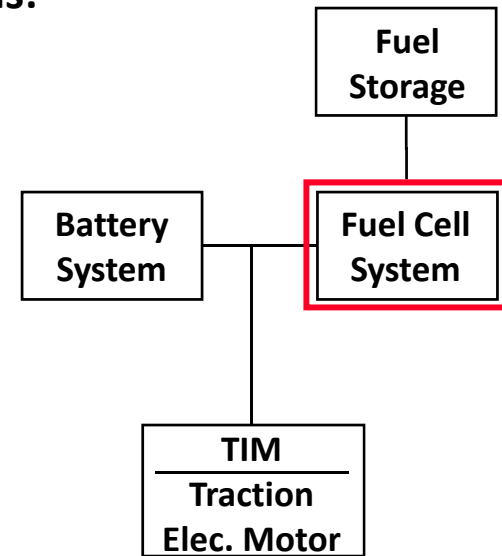

Project covers complete FC system (specifically excluding battery, traction motor/inverter, and storage)

General Rules

- **80kW_{net}** system (90 kW_{gross} for 2008 system)
- **1k to 500k** annual system production
- **U.S. labor rates: \$45/hr (fully loaded)** [previously \$60/hr]
- **\$1,100/troy oz.** Pt cost used for consistency

Some costs *NOT* included:

- **10% capital cost contingency**
- **Warranty**
- **Building costs** (equipment cost included but not building in which equipment is housed)
- **Sales Tax**
- **Non-Recurring Engineering Costs**
- **Markup for Fuel Cell Manufacturer**

DTI's DFMA[®]-Style Costing Methodology

- **DFMA[®] (Design for Manufacturing and Assembly)** is a registered trademark of Boothroyd-Dewhurst, Inc.
 - Used by hundreds of companies world-wide
 - Basis of Ford Motor Co. design/costing method for past 20+ years
- **DTI practices are a blend of:**
 - “Textbook” DFMA[®], industry standards & practices, DFMA[®] software, innovation and practicality

$$\text{Estimated Cost} = (\text{Material Cost} + \text{Processing Cost} + \text{Assembly Cost}) \times \text{Markup Factor}$$

Manufacturing rate cost factors:

1. Material Costs
2. Manufacturing Method
3. Machine Rate
4. Tooling Amortization

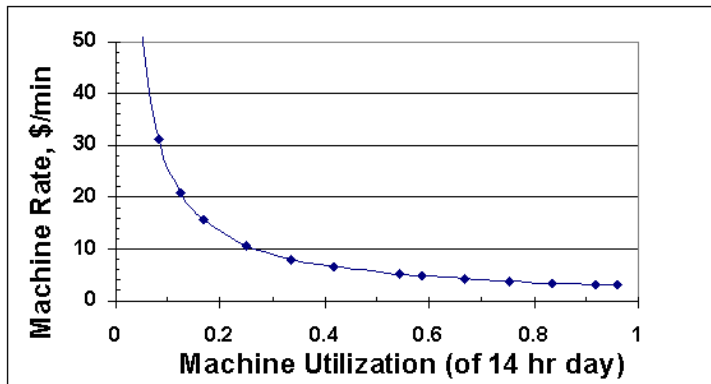

Methodology Reflects Cost of Under-utilization:

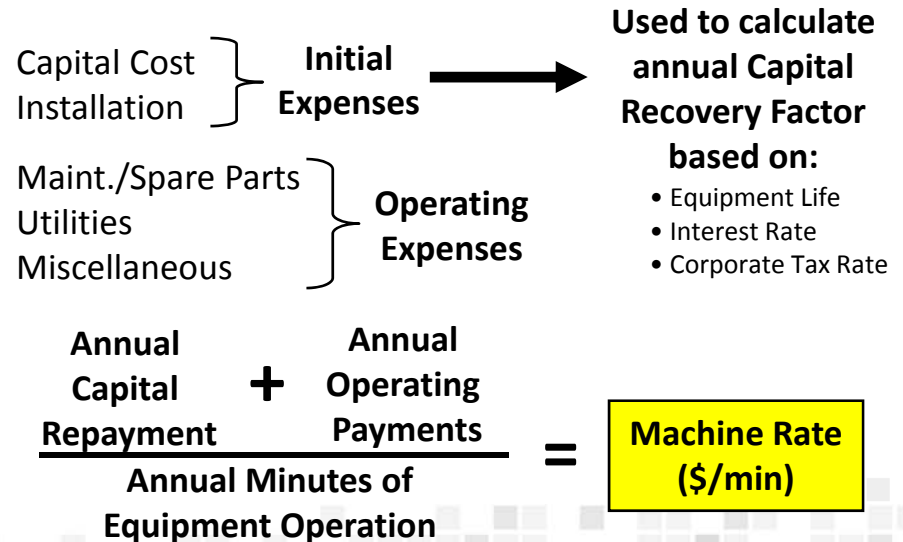

Key Technical Targets Define System

		2007 Status	2008 Status	2007 Status	2008 Status	2007 Status	2008 Status
DOE Tech. Targets that drive analysis:		Current (2007, 2008)		2010		2015	
Stack Efficiency @ Rated Power	%	55%	55%	55%	55%	55%	55%
MEA Areal Power Density @ Peak Power	mW/cm ²	583	715	1,000	1,000	1,000	1,000
Total Pt-Group Catalyst Loading	mg PGM/cm ²	0.35	0.25	0.30	0.30	0.20	0.20
Key Derived Performance Parameters:							
System Gross Electric Power (Output)	kW	90.2	90.2	86.7	86.7	87.1	87.1
Active Area	cm ²	417	339	233	233	234	234
Cell Voltage @ Peak Power	V/cell	0.677	0.676	0.677	0.676	0.677	0.676
Operating Pressure (Peak)	atm	2.3	2.3	2.0	2.0	1.5	1.5

- A few key DOE Technical Target values are used to anchor system definition
- All other system parameters flow from DTI calculations & judgment

System Comparison

	2008 Technology	2010 Technology	2015 Technology
Power Density (mW/cm ²)	715 (was 583)	1,000	1,000
Total Pt loading (mgPt/cm ²)	0.25 (was 0.35)	0.3	0.2
Operating Pressure (atm)	2.3	2	1.5
Peak Stack Temp. (°C)	70-90	99	120
Membrane Material	Nafion® on ePTFE	Advanced High-Temperature Membrane	Advanced High-Temperature Membrane
Radiator/Cooling System	Aluminum Radiator, Water/Glycol coolant, DI filter	Smaller Aluminum Radiator, Water/Glycol coolant, DI filter	Smaller Aluminum Radiator, Water/Glycol coolant, DI filter
Bipolar Plates	Stamped SS 316L with Coating	Stamped SS 316L with Coating	Stamped SS 316L with Coating
Air Compression	Twin Lobe Compressor, Twin Lobe Expander	Centrifugal Compressor, Radial Inflow Expander	Centrifugal Compressor, No Expander
Gas Diffusion Layers	Carbon Paper Macroporous Layer with Microporous layer applied on top	Carbon Paper Macroporous Layer with Microporous layer applied on top	Carbon Paper Macroporous Layer with Microporous layer applied on top
Catalyst Application	Double-sided vertical die-slot coating of membrane	Double-sided vertical die-slot coating of membrane	Double-sided vertical die-slot coating of membrane
Air Humidification	Water spray injection	Polyamide Membrane	None
H ₂ Humidification	None	None	None
Exhaust Water Recovery	SS Condenser (Liquid/Gas HX)	SS Condenser (Liquid/Gas HX)	None
MEA Containment	Injection molded LIM Hydrocarbon MEA Frame/Gasket around Hot-Pressed M&E	Injection molded LIM Hydrocarbon MEA Frame/Gasket around Hot-Pressed M&E	Injection molded LIM Hydrocarbon MEA Frame/Gasket around Hot-Pressed M&E
Coolant & End Gaskets	Laser Welding/Screen Printed Resin	Laser Welding/Screen Printed Resin	Laser Welding/Screen Printed Resin
Freeze Protection	Drain water at shutdown	Drain water at shutdown	Drain water at shutdown
H ₂ Sensors	2 for FC system 1 for passenger cabin (not in cost estimate) 1 for fuel system (not in cost estimate)	1 for FC system 1 for passenger cabin (not in cost estimate) 1 for fuel system (not in cost estimate)	None
End Plates/Compression System	Composite molded end plates with compression bands	Composite molded end plates with compression bands	Composite molded end plates with compression bands
Stack/System Conditioning	5 hours of power conditioning- from UTC's US Patent 7,078,118	4 hours of power conditioning- from UTC's US Patent 7,078,118	3 hours of power conditioning- from UTC's US Patent 7,078,118

Different Technology Schematics

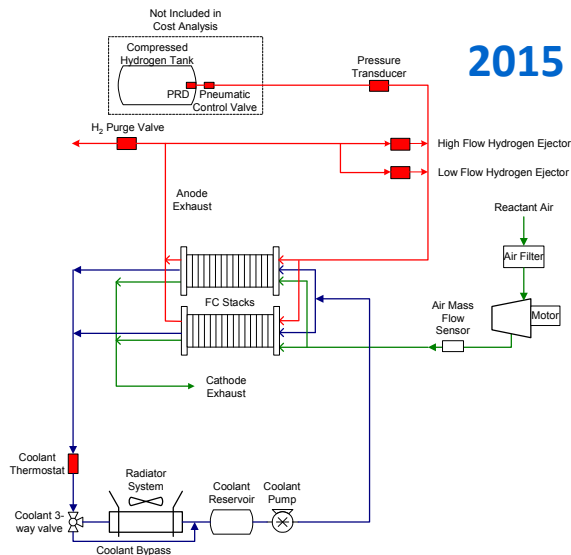
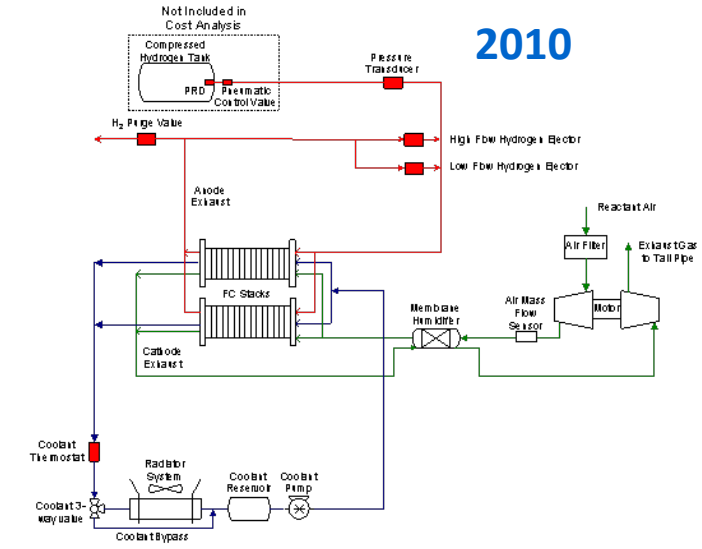
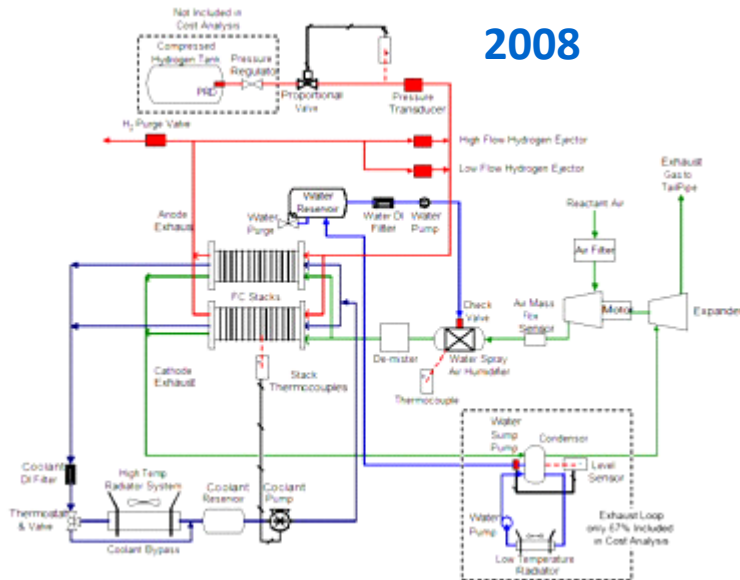

Changes from 2008 to 2010:

- Higher temperature, smaller radiator
- Use of membrane humidifier (instead of water spray)
- Lower pressure
- Centrifugal compressor/expander (instead of twin lobe compressor)

Changes from 2010 to 2015:

- Higher temperature, smaller radiator
- No humidification
- Lower pressure
- Smaller compressor
- No expander

PEM Fuel Cell Stack

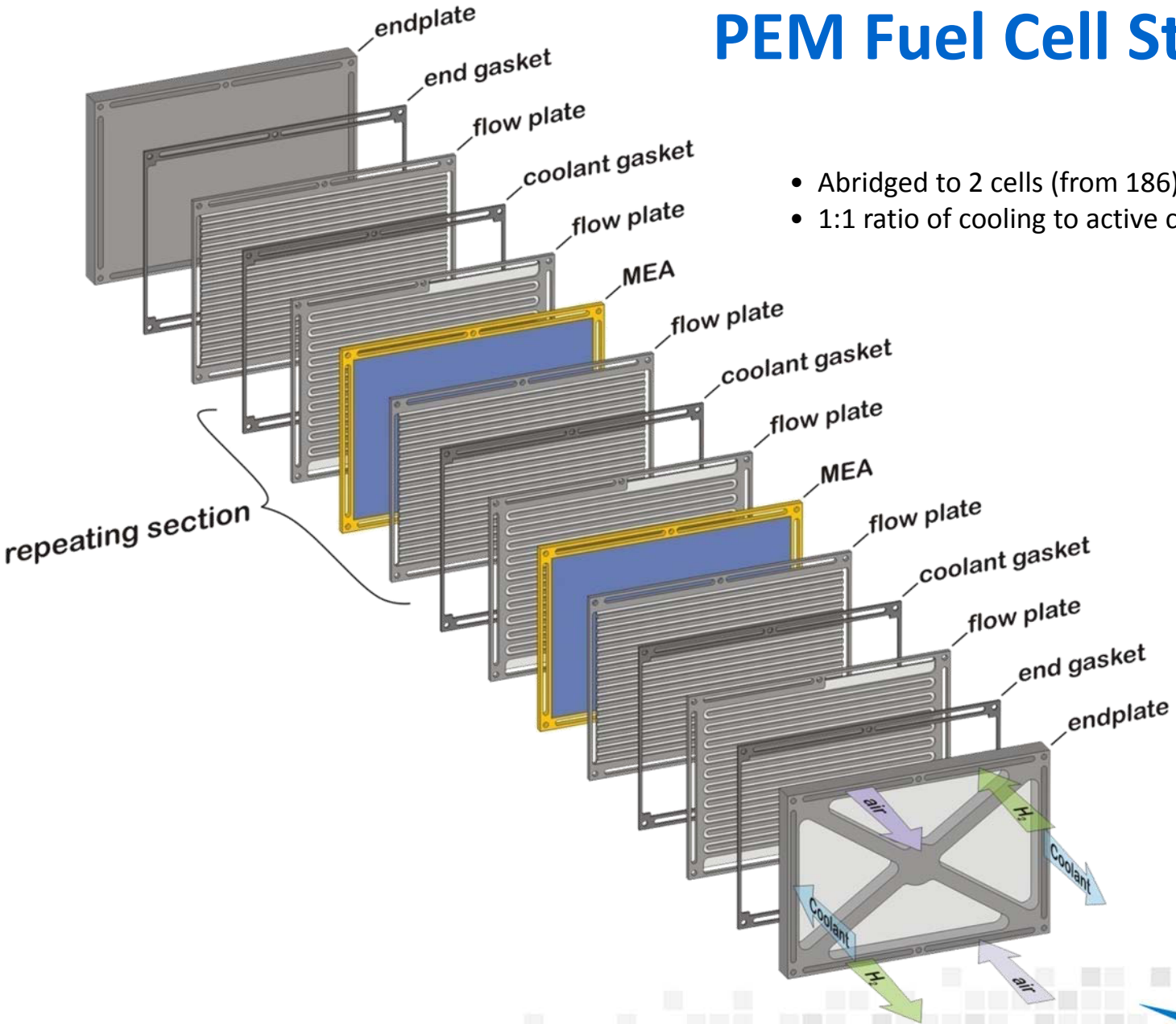

Noteworthy Changes Since 2007 Analysis

Current Technology, 500,000 Systems/Year

Item	Notes	Effect on System Cost (\$/kW _{net})
Technology Level	Changed baseline to "2008"	-
H ₂ Sensors	Updated the hydrogen sensor prices	(\$1.25)
System Controllers	Switched from 2 controllers to 1	(\$2.50)
Belly Pan	Added new DFMA [®] analysis	(\$0.21)
Power Density	Changed MEA areal power density to 715 mW/cm ²	(\$7.17)
Catalyst Loading	Changed total platinum-group catalyst loading to 0.25 mg/cm ²	(\$9.81)
Machine Lifetimes	Review and standardization of Machine Lifetimes	(\$0.05)
Wiring	Added new analysis	(\$0.55)
MEA Frame	Updated material costs, improved calculations	\$2.92
Humidifier	Improved water spray humidifier cost estimate	(\$0.33)
Bipolar Plates	Updated 316L and 304 sheet metal prices from Allegheny Ludlum	\$0.73
Materials & Machinery	Updated numerous material and machinery prices	\$1.92
Coolant & End Gaskets	Switched to laser-welded coolant & screen-printed end gaskets	(\$4.06)
Startup Battery	Removed the startup battery from the analysis	(\$0.63)
Exhaust Loop (formerly LTL)	Reduced to 67% of cost to account for duties not included in analysis	(\$0.70)
TreadStone Coating	Applied TreadStone coating on SS 316L stamped bipolar plates	\$1.77
Labor Rate	Labor rate lowered from \$60/hr to \$45/hr	(\$1.24)
Miscellaneous	Numerous small changes	\$2.65
Total System Cost (\$/kW_{net})		(\$18.51)

Stamped Stainless Steel Bipolar Plates

- Stamped using a 4-stage Progressive Die setup
- SS 316L
- Rapid plate production (up to 80/min)
- TreadStone coating process applied to finished plates

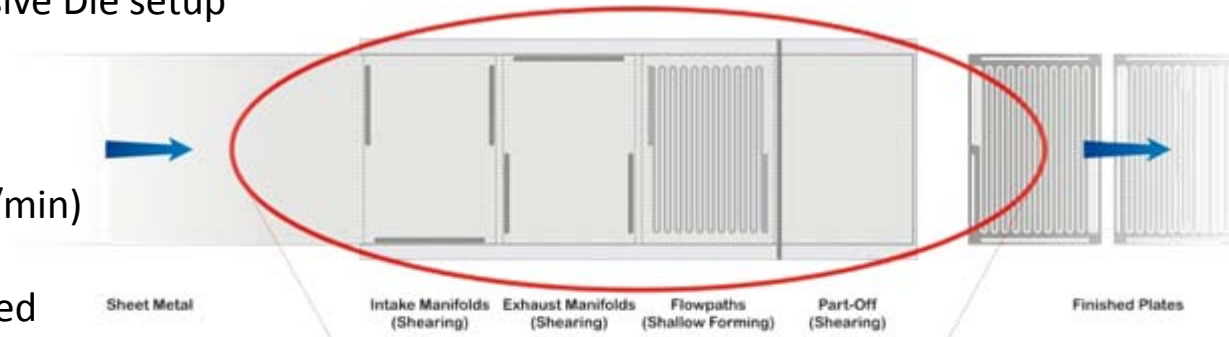

Stamped vs. other methods:

- Less brittle than composites
- Lower tooling cost than injection molding
- Lower gas permeation
- **Borderline corrosion resistance**
- **High contact resistance**

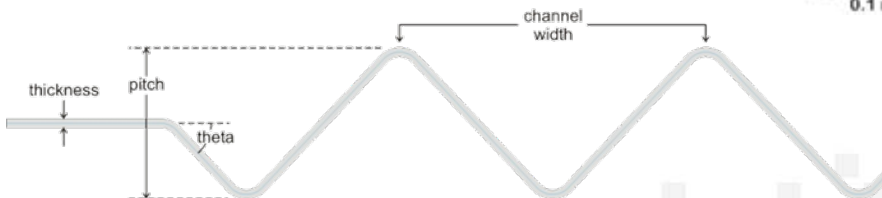
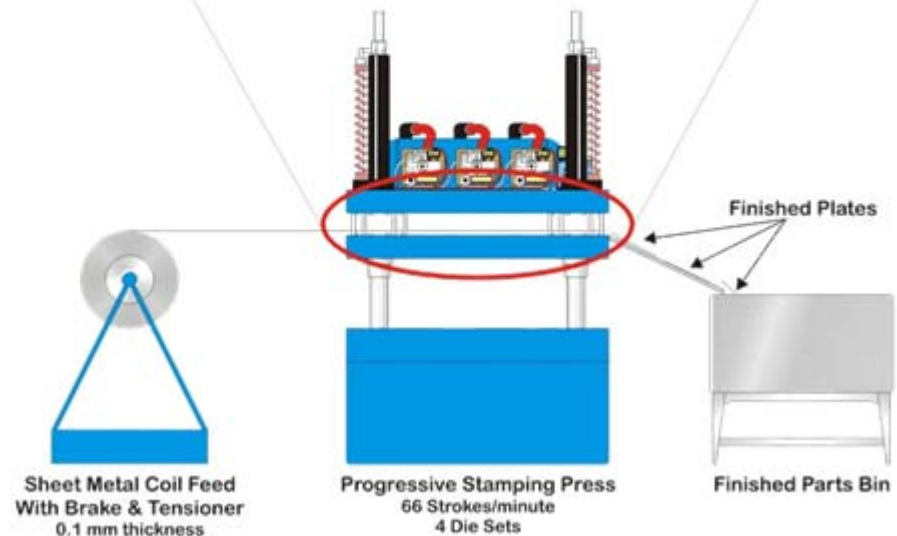

TreadStone Coatings for Stamped Bipolar Plates

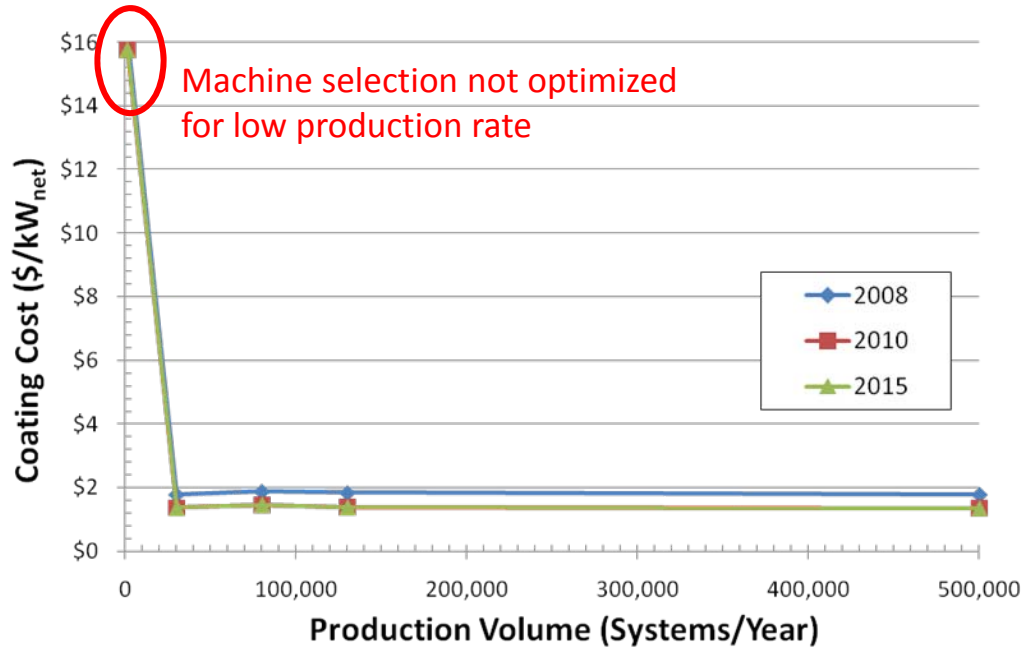

	2008	2015
316 SS Plate	\$6.34/kW _{net}	\$3.82/kW _{net}
TreadStone Coating	\$1.77/kW _{net}	\$1.34/kW _{net}
316 SS Plate (coated)	\$8.11/kW _{net}	\$5.16/kW _{net}

- Multiple coatings/treatments approaches evaluated. TreadStone LiteCell™ approach was judged to be most feasible, cost-effective, and representative of future likely approaches.
- NDA signed with TreadStone Technologies Inc., collaborated closely to model their multi-step process
- Based on US patent # 7,309,540 B2, and proprietary parameters
- Conducted in-depth evaluation based on detailed equipment manufacturer specifications
 - Machinery schematics, capital costs, machine rates, etc.
- Analyzed the impact of switching from SS 316 to the cheaper SS 304 for coated plates
 - Cost savings of SS 304 is small
 - Further savings might be achieved with cheaper plate materials such as Aluminum

Coolant Gaskets

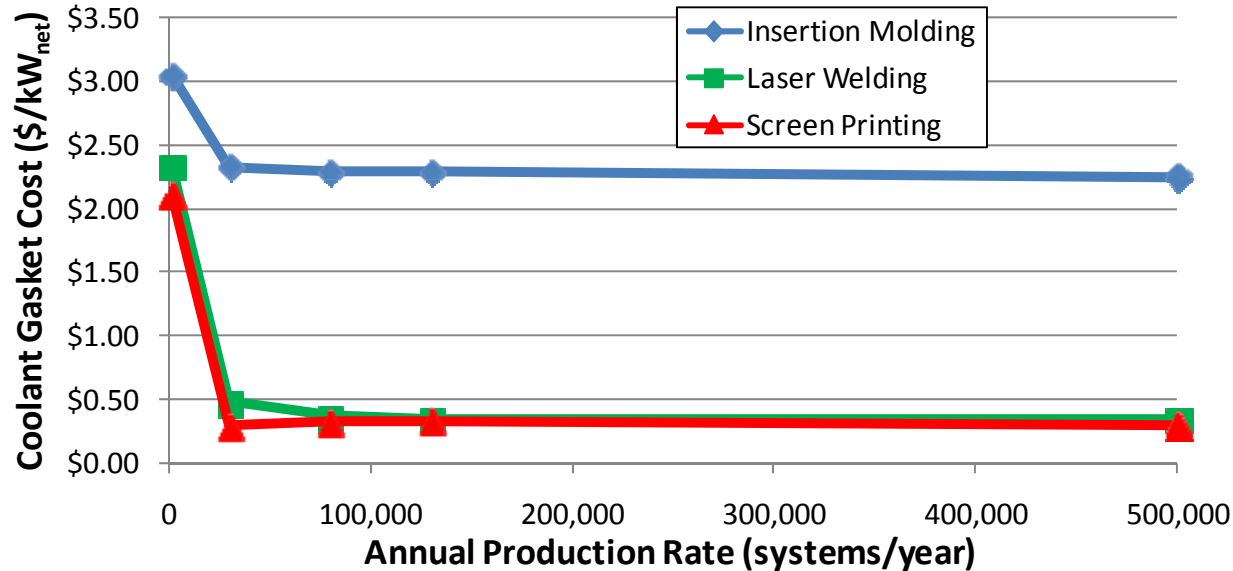

- Coolant Gasket: gasket between faces of bipolar plates that form coolant cell
- *2007 Analysis* used insertion molding for creation of coolant gaskets
- 2 new gasketing methods examined:
 - Laser Welding & Screen Printing
 - Both provide cost savings over Insertion Molding (especially with updated (higher) insertion-molded material costs)
- **Laser Welding selected**
 - Standard industry approach
 - **No material costs** (not counting consumables such as argon gas)
 - Indexed process, cycle time ranges from **2 sec** to **6 sec**, depending on machine used
 - **\$400k** process line used for 1,000 sys/year, faster **\$800k** process line used for other 4 rates
 - **\$0.31/kW_{net}** (2008 tech., 500k sys/year)

End Gaskets

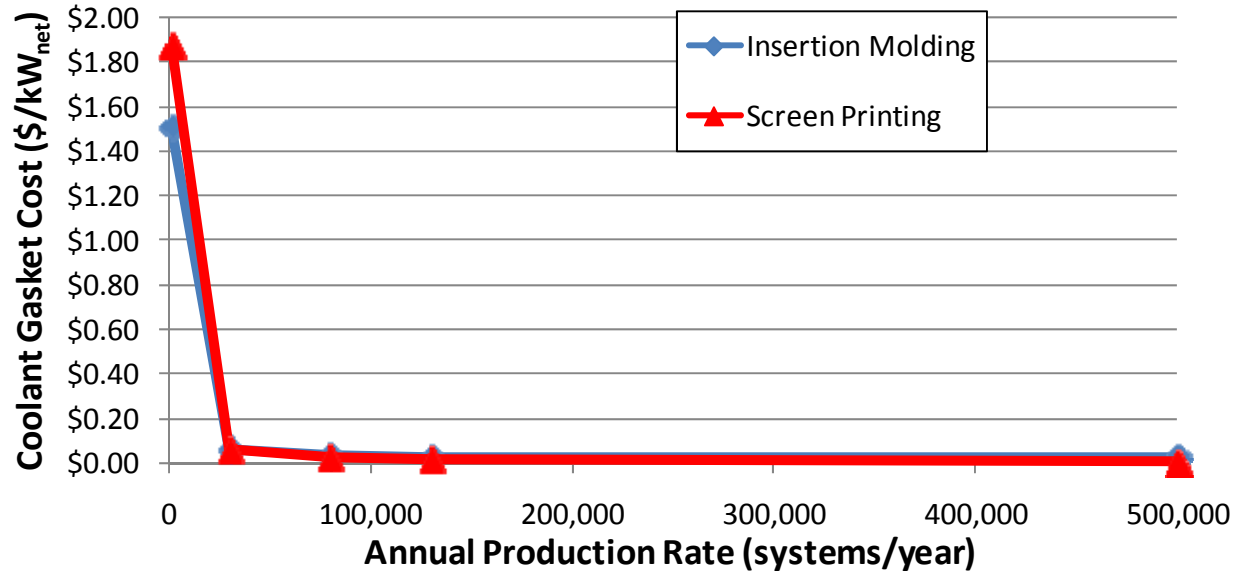

- End gaskets are similar to coolant gaskets, except:
 - They sit between the end plate & a bipolar plate and there are only 4 per system
- *2007 Analysis* used insertion molding for creation of end gaskets
- **Screen printing** method examined (welding not an option with composite end plates):
 - Provides cost savings over Insertion Molding (especially with updated (higher) insertion-molded material costs)
 - Formula-A Resin (from Dana Corp. Patent) printed onto the stainless steel bipolar plates
 - Indexed process, cycle time ranges from **9.8 sec** to **3.1 sec**, depending on machine used
 - slower **\$387k** process line used for lowest 4 rates, faster **\$638k** process line used for 500k sys/year
 - UV Curing, robotic handling
 - **\$0.01/kW_{net}** (2008 tech., 500k sys/year)

MEA Frame/Gasket

Insertion molding of gasket around MEA

Henkel Loctite Liquid Injection-Moldable (LIM) Hydrocarbon

- **\$43.37/kg** (for 500k systems/year)
- Low **1.05 g/cc** density

		Generic Silicone (2007 Analysis)	Henkel Loctite Silicone 5714	DuPont Viton® GBL-600S	DuPont Viton® GF-S	Henkel Loctite LIM Hydrocarbon
Density	g/cc	1.4	1.05	1.84	1.92	1.05
Cost	\$/kg	\$14.33	\$56.70	\$36.87	\$36.87	\$43.37
Cost	\$/L	\$20.06	\$59.54	\$67.84	\$70.79	\$45.54
Cure Time	s	150	540	420	180	60
Cure Temp	°C	127	130	177	187	130
Durability	hrs	~5,000	~5,000	~15,000	~15,000	~10,000
Inj. Mold Pressure		low	low	mid-to-high	mid-to-high	low

Red = Best in category

New Henkel Loctite material shows lots of promise

- Excellent combination of durability, low cost, and ease of manufacture

Process:

- Vacuum mixer to remove air bubbles
- **1 min** cycle time at **130°C**
- Add'l room temperature cure outside of mold
- **\$5.17/kW_{gross}** (2008 tech., 500,000 sys/year)

MEA with Integrated Seal

Ballard Patent US 7,070,876

July 4, 2006

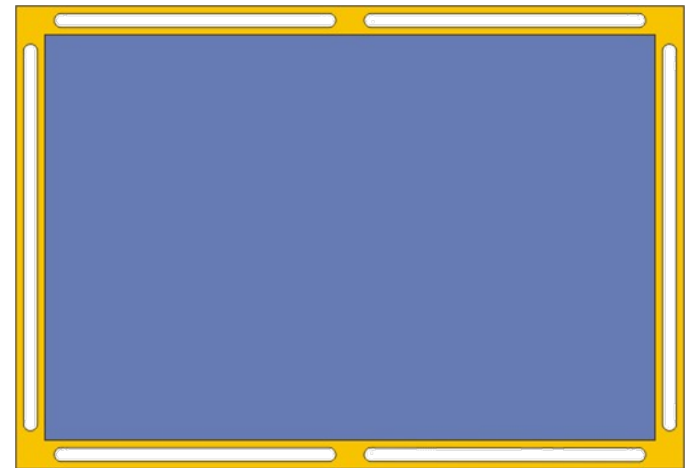
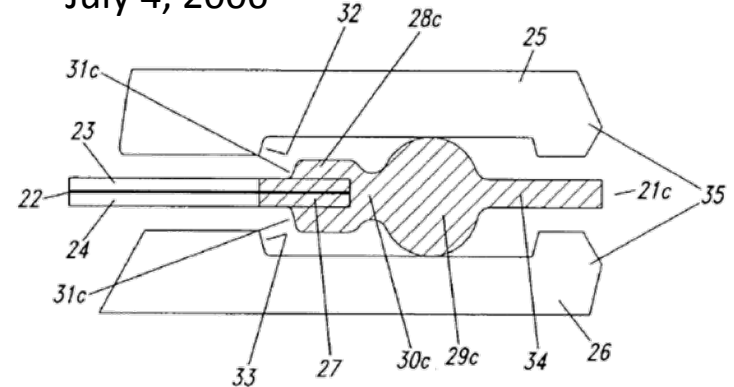

Stack Component Cost Distribution

1,000 systems (2008)

1,000 systems (2010)

1,000 systems (2015)

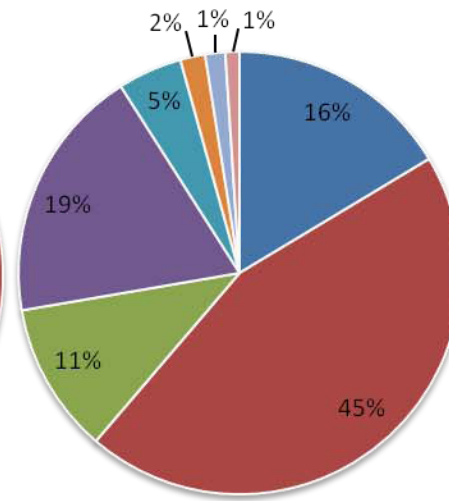
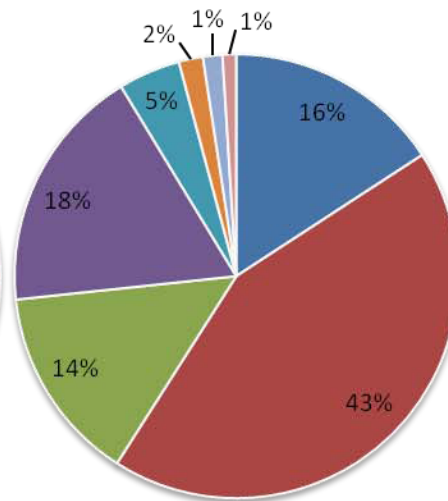
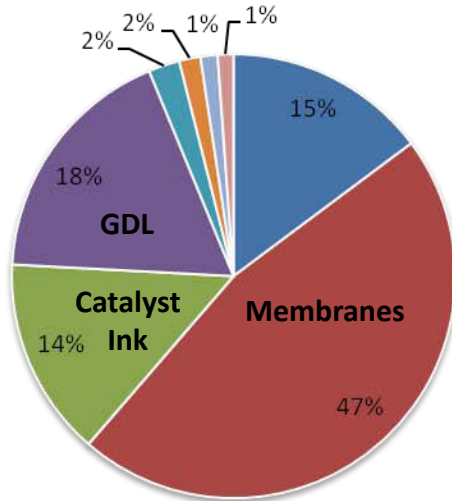

- Bipolar Plates (Stamped)
- Membranes
- Catalyst Ink & Application
- GDLs
- MEA Frame/Gaskets
- Coolant Gaskets (Laser Welding)
- End Gaskets (Screen Printing)
- End Plates

500,000 systems (2008)

500,000 systems (2010)

500,000 systems (2015)

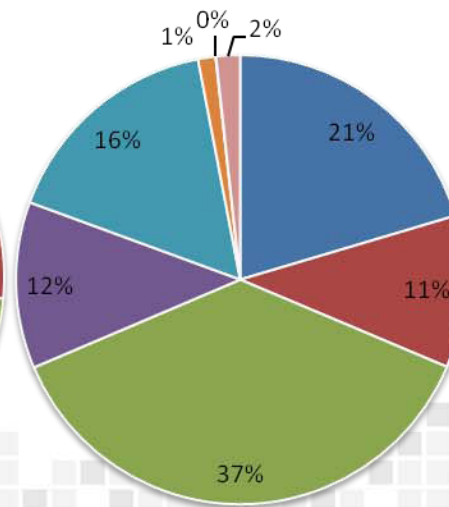
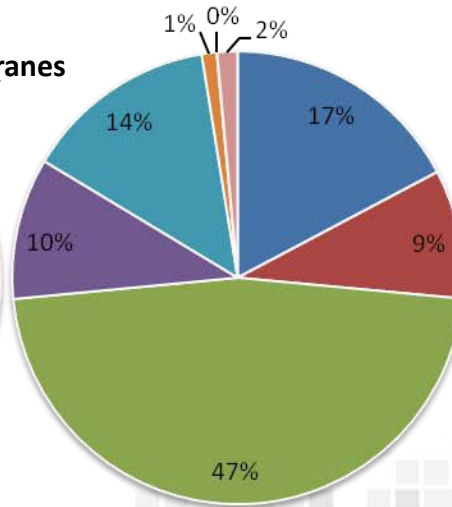
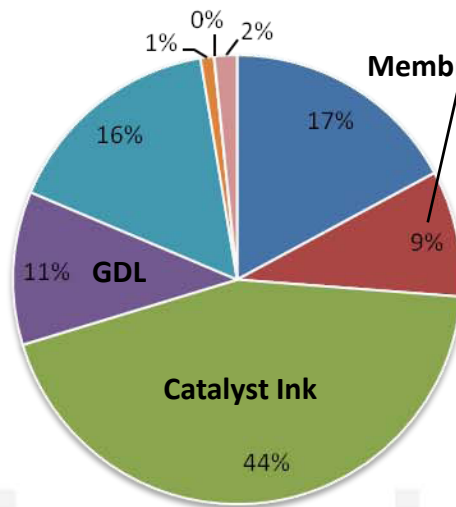

- Membrane dominates cost at low production
- Catalyst Ink dominates cost at high production
- Top 3 costs:
 - Membrane
 - Catalyst Ink
 - GDL

Platinum Cost

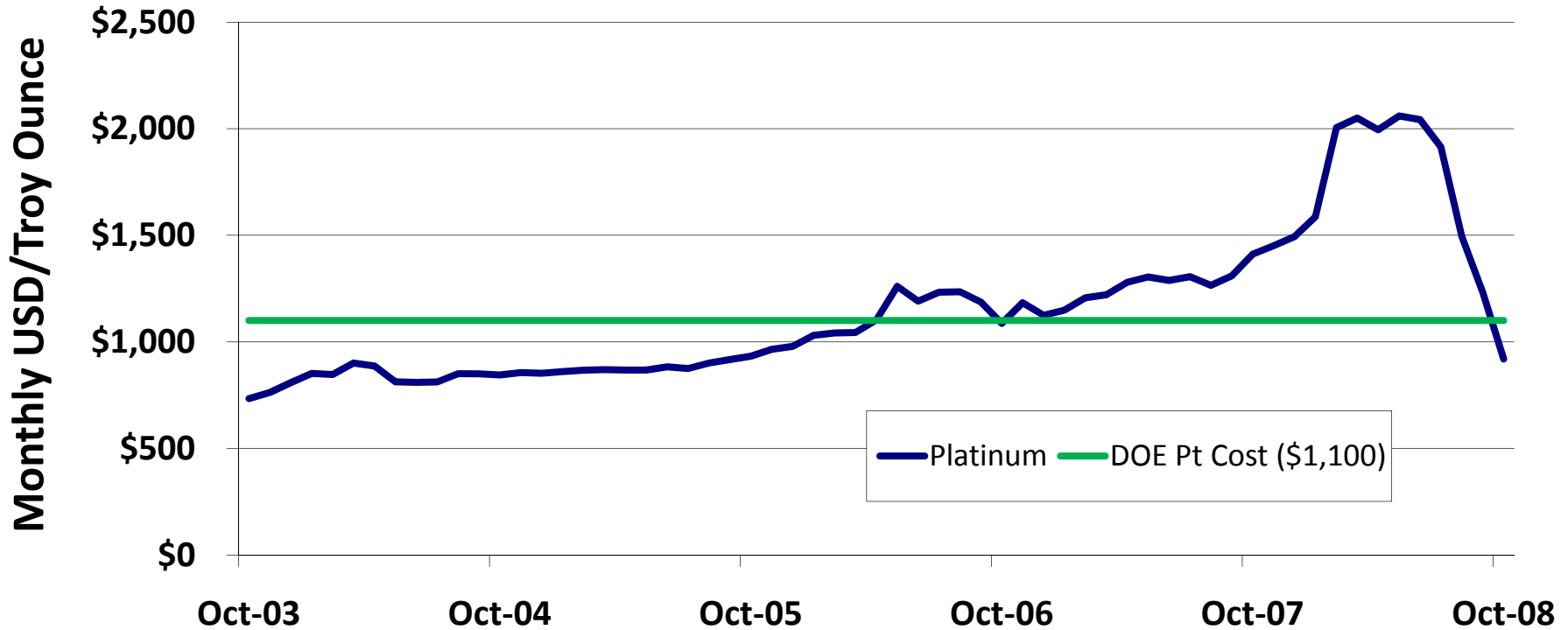

- Currently trading at **~\$1150/tr.oz.**
- Platinum cost is highly variable:
 - **3/04/08:** \$2,280/tr.oz.
 - **10/27/08:** \$782/tr.oz.
- Consistent use of \$1,100 facilitates “apples-to-apples” system costs comparison
- Especially for the current technology system, Pt is a major system cost component, so estimates are highly susceptible to Pt cost fluctuations

Hydrogen Sensors

- Makel Engineering sensors
 - Better, cheaper technology than in 2007 system

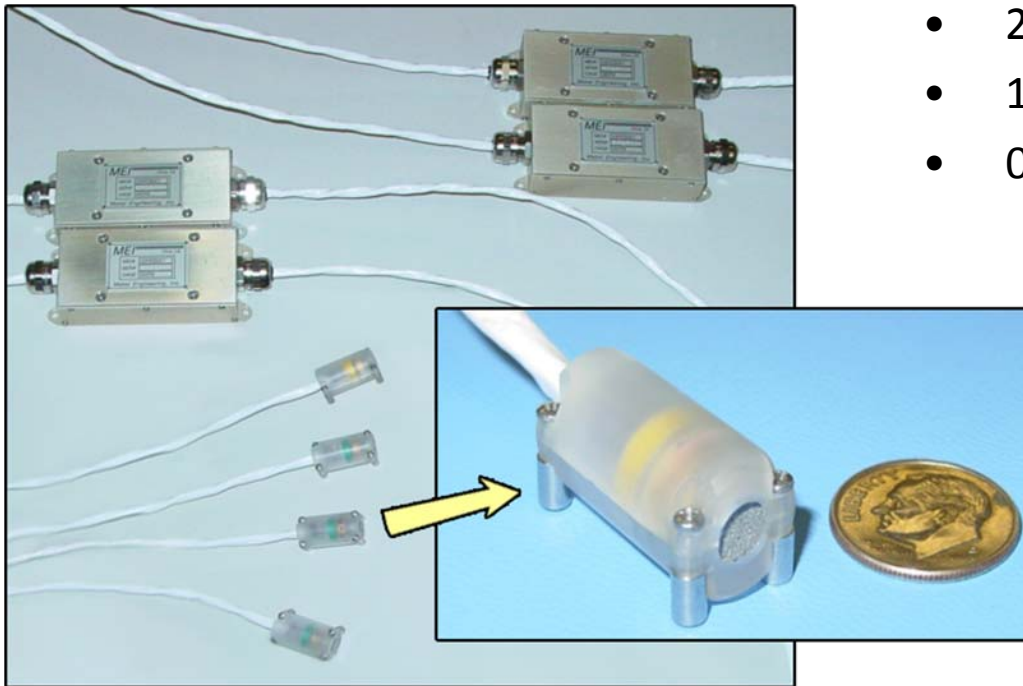

- 2 sensors/system at 2008 tech.
- 1 per system for 2010 tech.
- 0 per system for 2015 tech.

- **\$850/sensor** vs. \$2000 in '07 Analysis
 - 1k sys/year, 2008 tech.
- **\$100/sensor** vs. \$150 in '07 Analysis
 - 500k sys/year, 2008 tech.

Belly Pan

		Annual Production Rate	1,000	30,000	80,000	130,000	500,000
2008 Analysis	2008	Materials (\$/system)	\$3.88	\$3.88	\$3.88	\$3.88	\$3.88
		Manufacturing (\$/system)	\$22.47	\$1.65	\$1.31	\$0.88	\$0.35
		Tooling (\$/system)	\$39.91	\$1.33	\$0.44	\$0.27	\$0.07
		Total Cost (\$/system)	\$66.27	\$6.87	\$5.64	\$5.04	\$4.30
		Total Cost (\$/kW_{net})	\$0.83	\$0.09	\$0.07	\$0.06	\$0.05
		2010	Materials (\$/system)	\$3.88	\$3.88	\$3.88	\$3.88
	Manufacturing (\$/system)		\$22.47	\$1.65	\$1.31	\$0.88	\$0.35
	Tooling (\$/system)		\$39.91	\$1.33	\$0.44	\$0.27	\$0.07
	Total Cost (\$/system)		\$66.27	\$6.87	\$5.64	\$5.04	\$4.30
	Total Cost (\$/kW_{net})		\$0.83	\$0.09	\$0.07	\$0.06	\$0.05
	2015		Materials (\$/system)	\$3.88	\$3.88	\$3.88	\$3.88
		Manufacturing (\$/system)	\$22.47	\$1.65	\$1.31	\$0.88	\$0.35
Tooling (\$/system)		\$39.91	\$1.33	\$0.44	\$0.27	\$0.07	
Total Cost (\$/system)		\$66.27	\$6.87	\$5.64	\$5.04	\$4.30	
Total Cost (\$/kW_{net})		\$0.83	\$0.09	\$0.07	\$0.06	\$0.05	
2007 Analysis		2007	Total Cost (\$/system)	\$400.12	\$41.12	\$17.58	\$12.18
	Total Cost (\$/kW_{net})		\$5.00	\$0.51	\$0.22	\$0.15	\$0.07
	2010	Total Cost (\$/system)	\$219.04	\$29.19	\$13.09	\$9.38	\$5.02
		Total Cost (\$/kW_{net})	\$2.74	\$0.36	\$0.16	\$0.12	\$0.06
	2015	Total Cost (\$/system)	\$219.66	\$29.27	\$13.12	\$9.40	\$5.02
		Total Cost (\$/kW_{net})	\$2.75	\$0.37	\$0.16	\$0.12	\$0.06

- New bottom-up DFMA[®] analysis
- Vacuum thermoforming process
- Polypropylene, **\$1.15/kg**
- Manual Loading used at all mfg. rates except 500k/year
- **\$0.05/kW_{net}** (500k/year)

Wiring

- New bottom-up analysis
 - Detailed wiring requirements & BOM
 - Vendor quotes on wires/connectors
- Analysis only covers materials costs
(installation covered in system assembly)

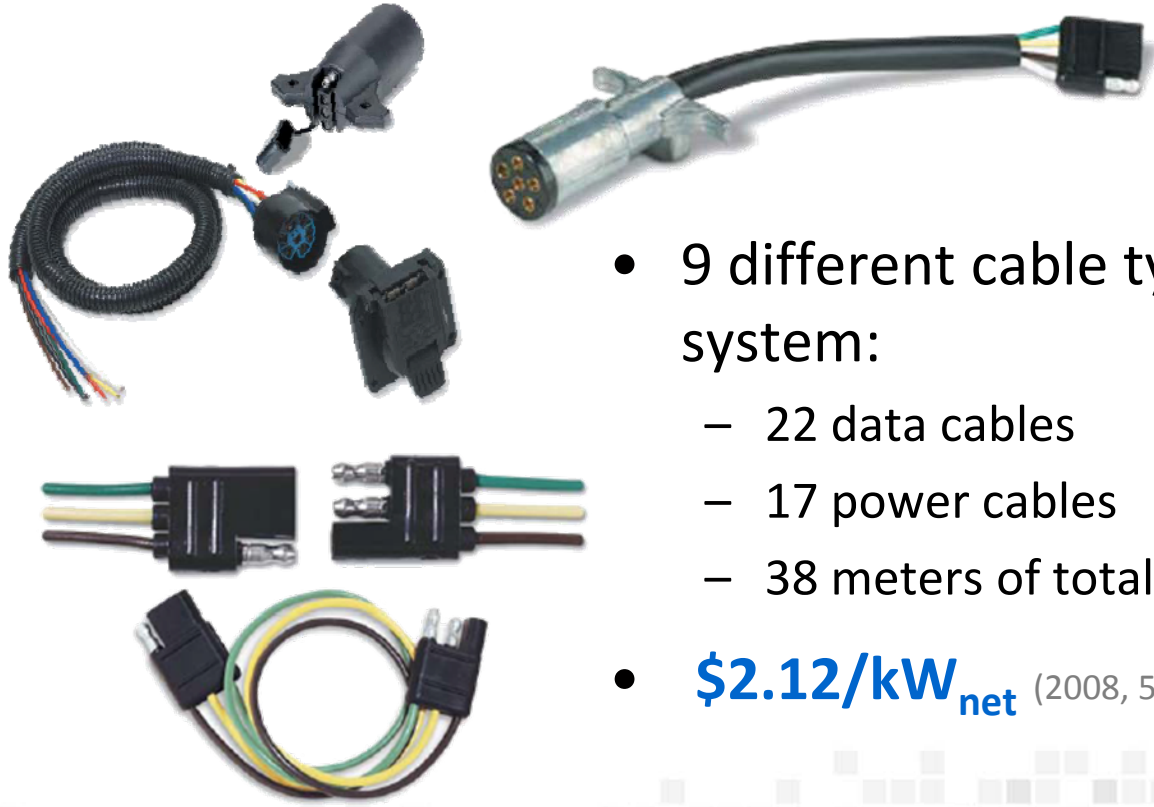

- 9 different cable types in each system:
 - 22 data cables
 - 17 power cables
 - 38 meters of total length
- **\$2.12/kW_{net}** (2008, 500k sys/year)



CMEU Cost Study with Honeywell

- CMEU = Compressor-Motor-Expander Unit
- CMEU has a large impact on the total system cost:
 - **10.3%** of system cost (2008, 500k systems/year)
 - **11.4%** of gross power (2008, 500k systems/year)
- Partnering with Honeywell to determine a detailed CMEU cost for each of two existing designs, plus the associated control electronics:
 - Turbocompressor/motor unit for ~2 atm fuel cell operation
 - Supercharger unit for ~1.5 atm fuel cell operation
- Honeywell is providing detailed cost breakdowns based largely on vendor quotes for detailed CAD drawings
- DTI is developing a new DFMA® model for CMEU
- DTI & Honeywell will analyze designs for possible cost-saving improvements
- Results will go into 2009 system analysis

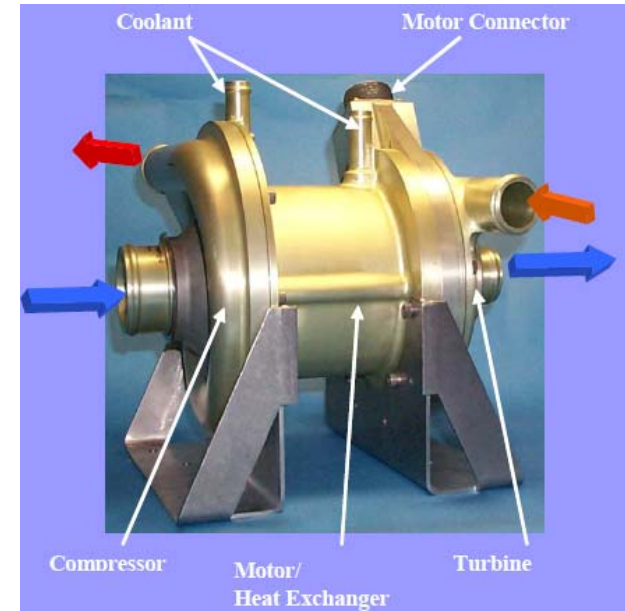

Balance of Plant

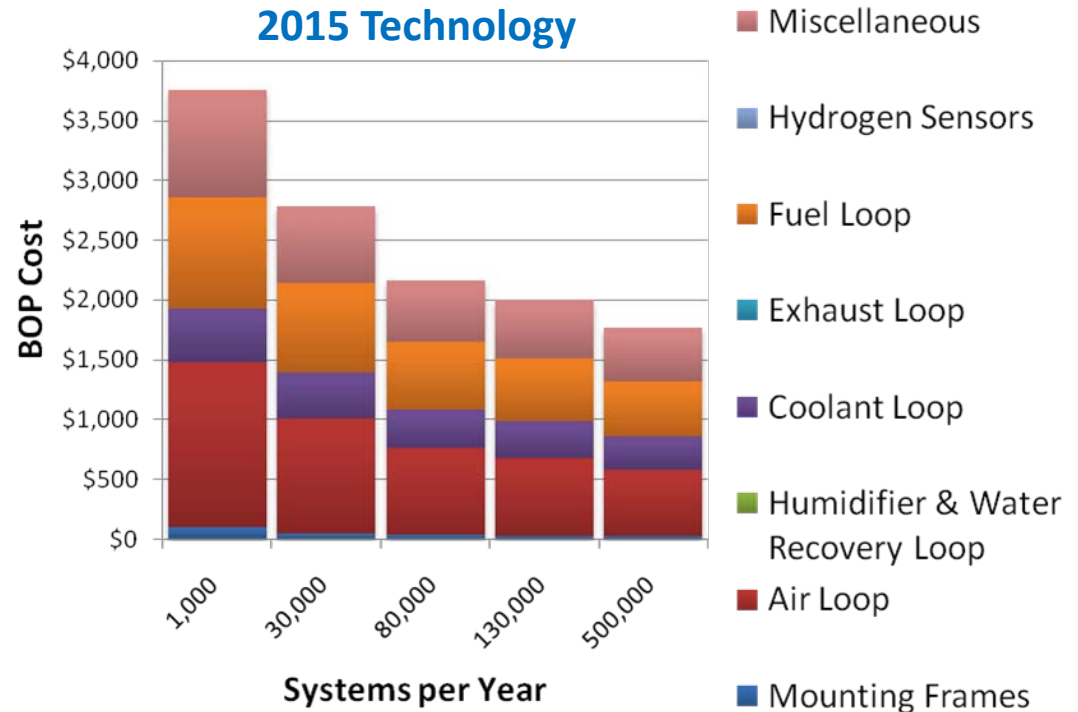
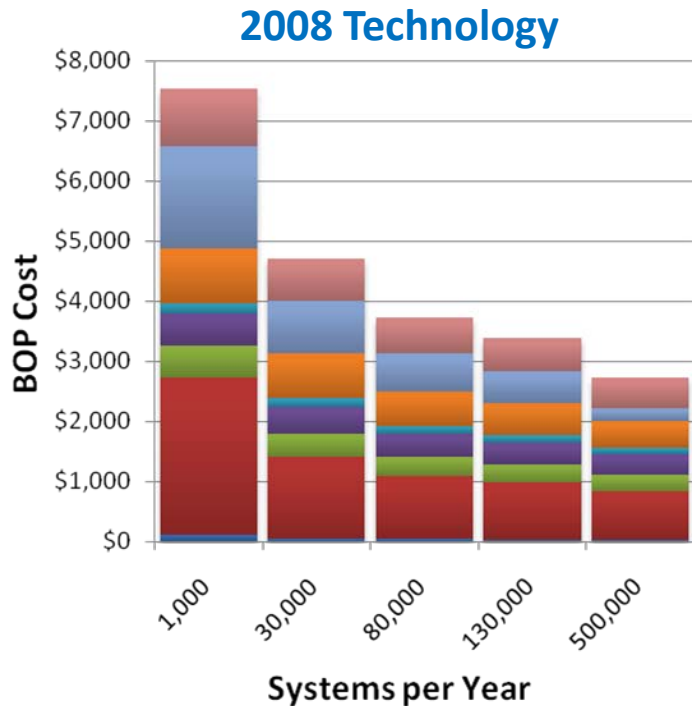

- Increases in manufacturing rate leads to largest savings.
- Air Compressors and Sensors are the two categories that have the largest \$ decline, together yielding 70% of the BOP cost decline from low production to high production.

- Technology changes yields lesser BOP savings and comes in form of reduced/eliminated components.
- Simplifications of Air, Humidifier, & Coolant Loops yield majority of technology improvement savings.

Stack & System Costs vs. Annual Production Rate

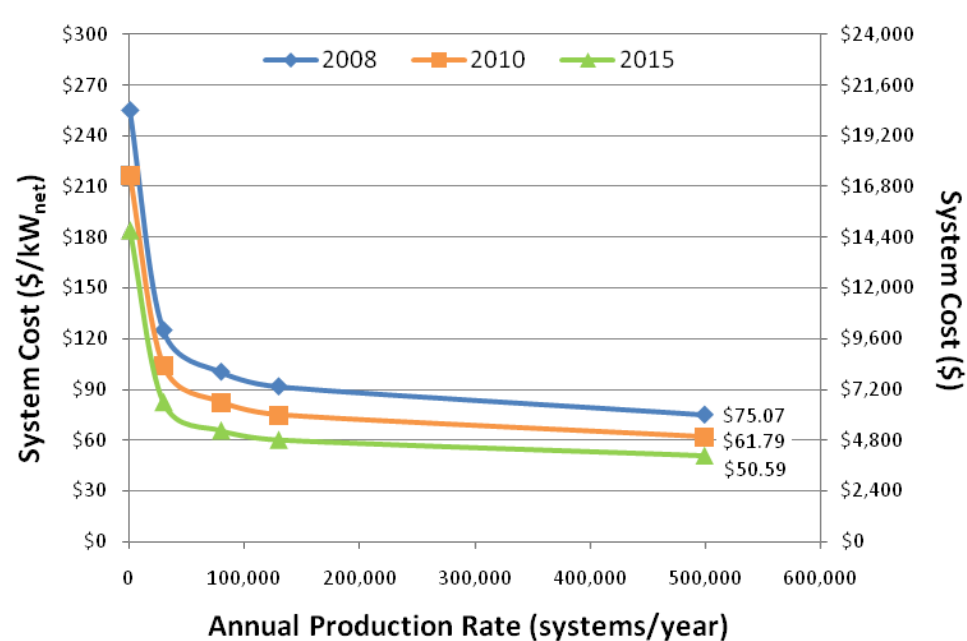
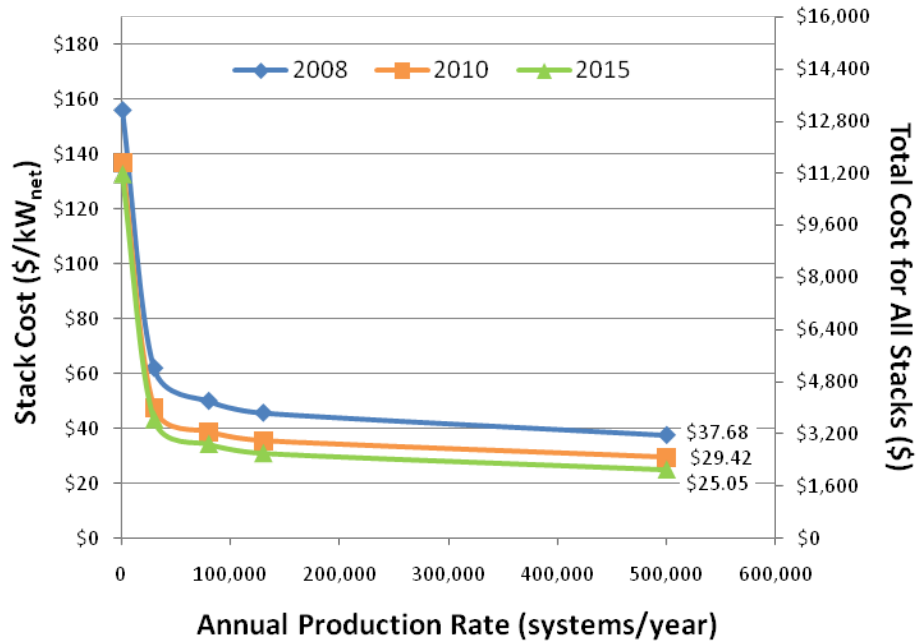

- Power Density = **715 mW/cm²**
- Catalyst Loading = **0.25 mgPt/cm²**

			2007 Status	2008 Status	2007 Status	2008 Status	2007 Status	2008 Status
			Current (2007, 2008)		2010		2015	
DOE Target:	Stack Cost	\$/kW _{e (net)}	-	-	\$25	\$25	\$15	\$15
Study Estimate:	Stack Cost	\$/kW _{e (net)}	\$50	\$38	\$27	\$29	\$23	\$25
DOE Target:	System Cost	\$/kW _{e (net)}	-	-	\$45	\$45	\$30	\$30
Study Estimate:	System Cost	\$/kW _{e (net)}	\$94	\$75	\$66	\$62	\$53	\$51

Sensitivity Analysis

System Cost (\$/kW_{net}): 2008 Technology, 500,000 systems/year

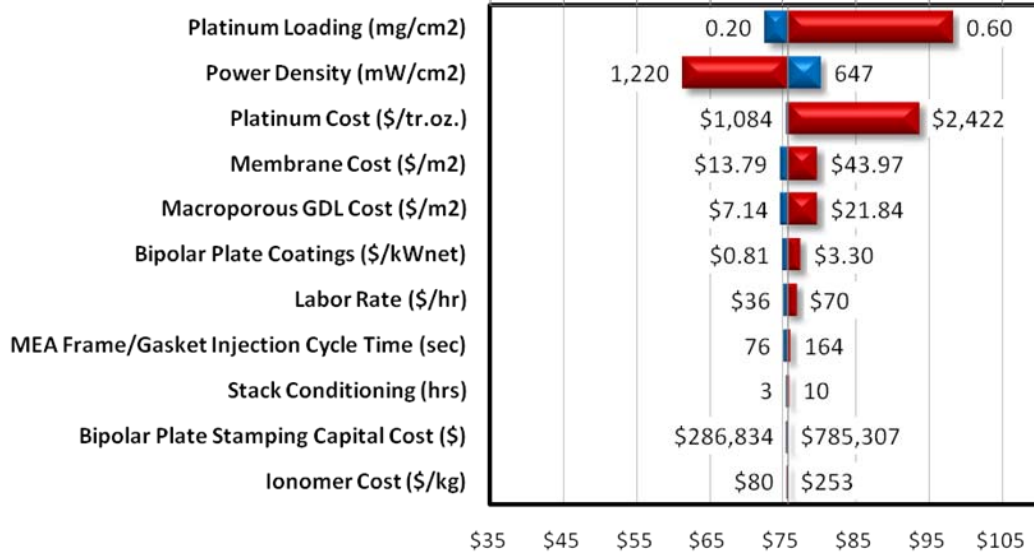

- **Power density, Platinum Loading, and Platinum cost** are by far the three largest elements of cost uncertainty

- In the 2015 system, the platinum doesn't have as much effect due to the higher assumed power density.

System Cost (\$/kW_{net}): 2015 Technology, 500,000 systems/year

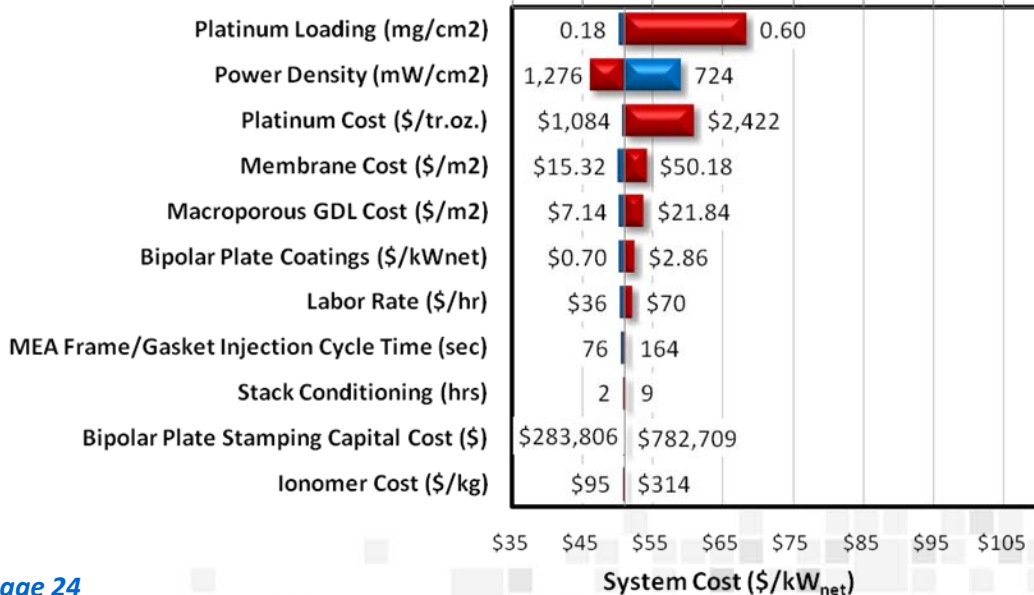

- Uncertainties in **Stack conditioning** and **Bipolar plate stamping cost** have negligible effect on the total system cost.

Progress in the Analysis

Over the last three years of analysis:

The current technology cost projection has dropped by **29%** (at 500,000 sys/year) due to a combination of technology improvement and analysis refinement

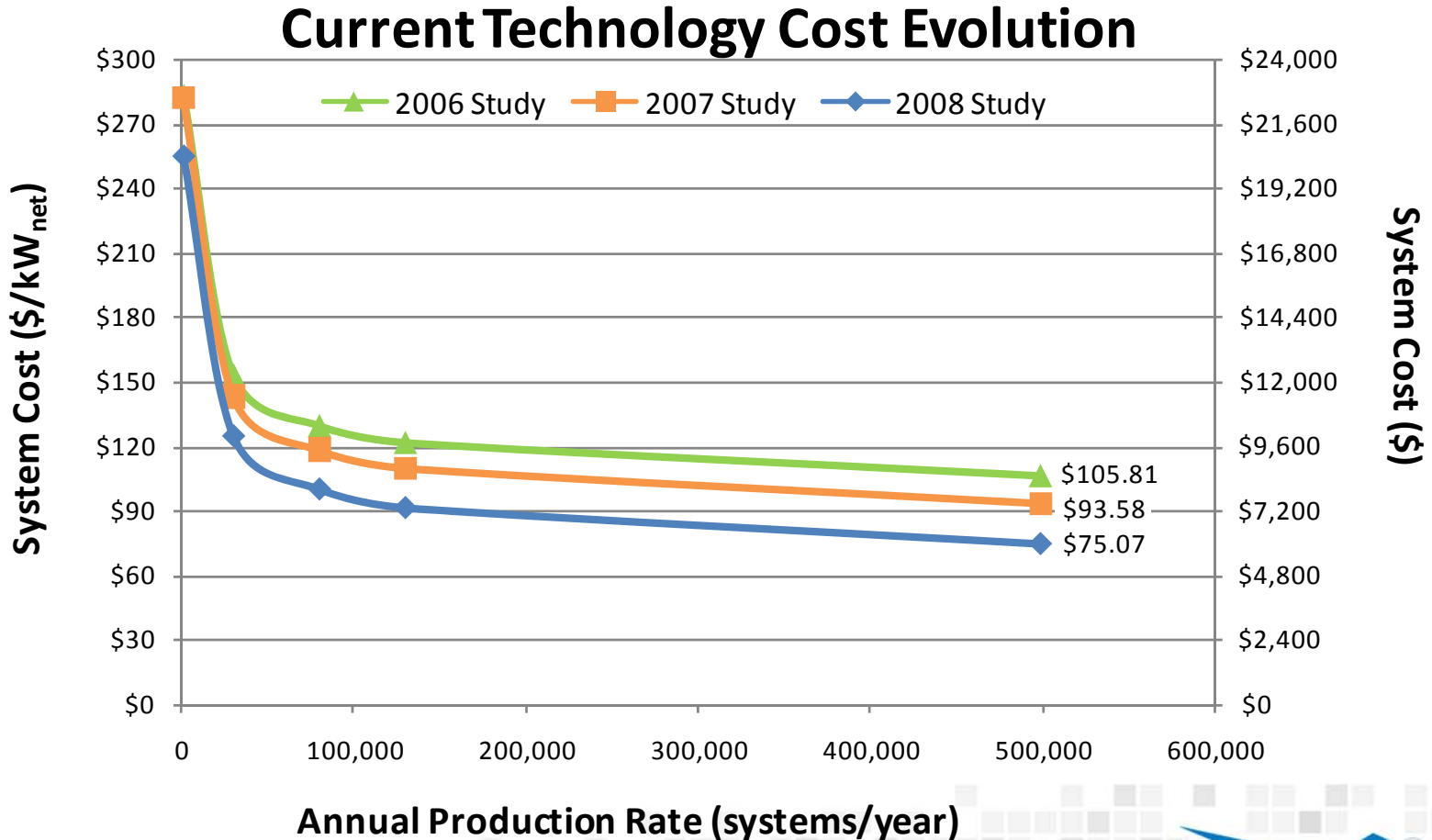

Future Work

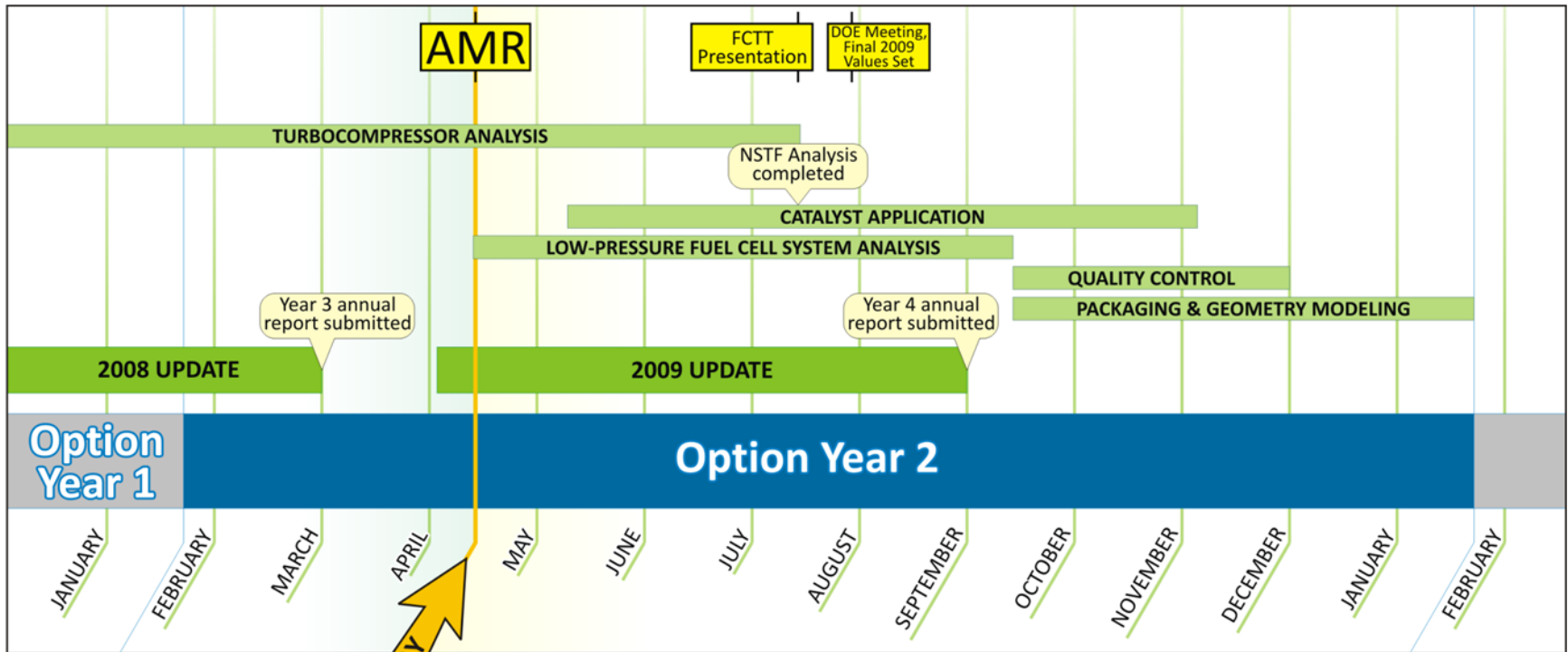

2009 Annual Update:

- New technology analysis
- Expanded sensitivity analysis
- Documentation & reporting

Additional Tasks:

- Low-Pressure Fuel Cell System Analysis
- Catalyst Application
 - Examine process options in detail (NSTF, decal, inking)
 - Build options into existing model, select best method

- Quality Control
 - Analyze impact of applying QC measures across all processes
- Packaging & Geometry Modeling
 - Refine BOP geometry
 - Ensure spatial feasibility of FC system in vehicle
- Turbocompressor Analysis
 - Continue work with Honeywell to examine existing CMEU designs
 - Develop detailed cost breakdown, identify new cost-saving pathways

End of Presentation

Thank you.

Additional Slides

The following slides are provided for further clarification

Catalyst Ink

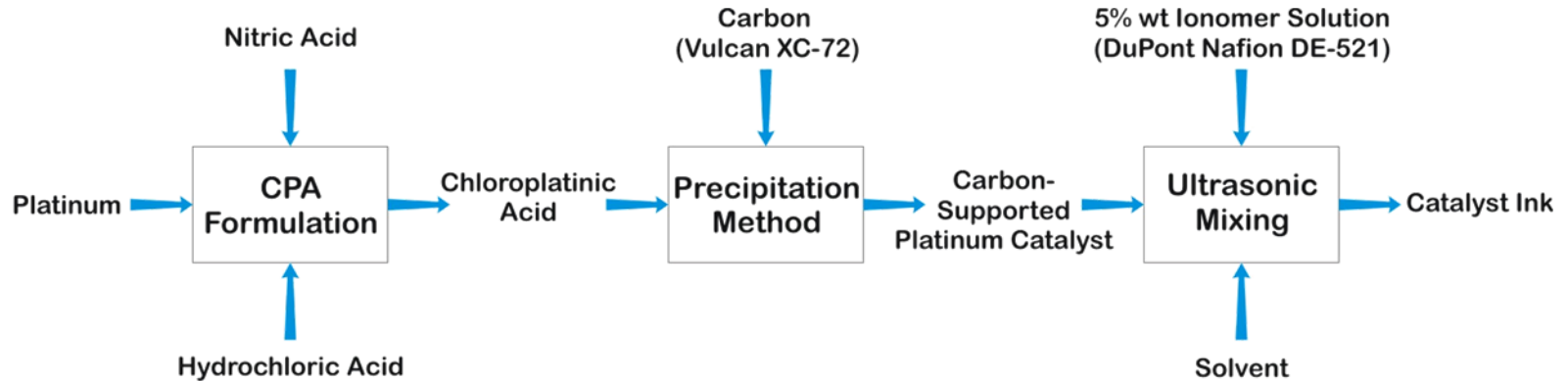

Catalyst Preparation

- Batch Pt-precipitation onto Vulcan XC-72 carbon support via a hexachloroplatinic acid (CPA) precursor (notional E-TEK-like precipitation method)

Catalyst Ink composition

- 7% (wt) Nafion® Ionomer
- 15% (wt) Carbon supported Pt (40% (wt) Pt on Vulcan XC-72)
- 78% (wt) Solvent (50/50 mixture of methanol and DI water)
- Mixed Ultrasonically
- Material costs are dominated by the platinum (\$1,100/tr. oz.)

Catalyst Application

Coatema VertiCoater

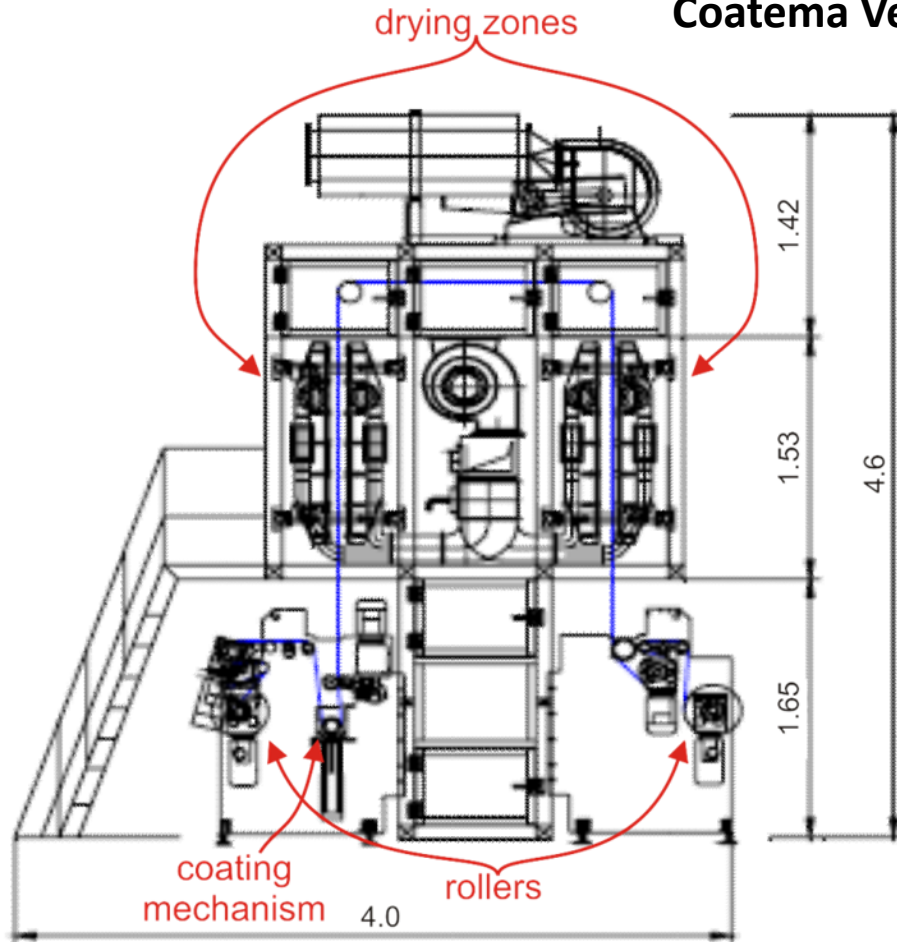

Size L/W/H: 4.0 x 1.7 x 4.6 m
Power Consumption: ~50 kW
Weight: ~4000 kg
Speed: 0.1 - 15 m/min
Roll Width: 50 - 1000 mm
Drying: Infrared 3 m - 6 m jet dryer

- Dual-sided Vertical coating process
 - Die-slot catalyst applicator
 - Modeled as Coatema VertiCoater
- Simultaneously applies catalyst slurry to both sides of the membrane
- Maximum roll width of **1 meter**
- Line speed of **10m/min**
- **\$750,000 capital cost/line** (not counting 40% for installation)

DTI's DFMA[®]-Style Costing Methodology (Cont'd)

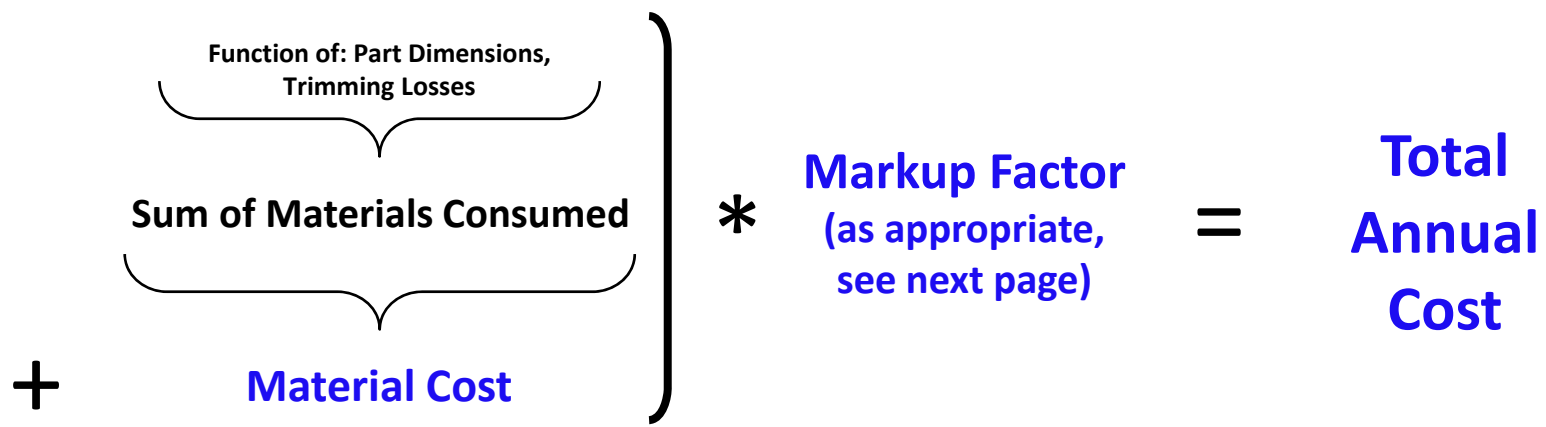
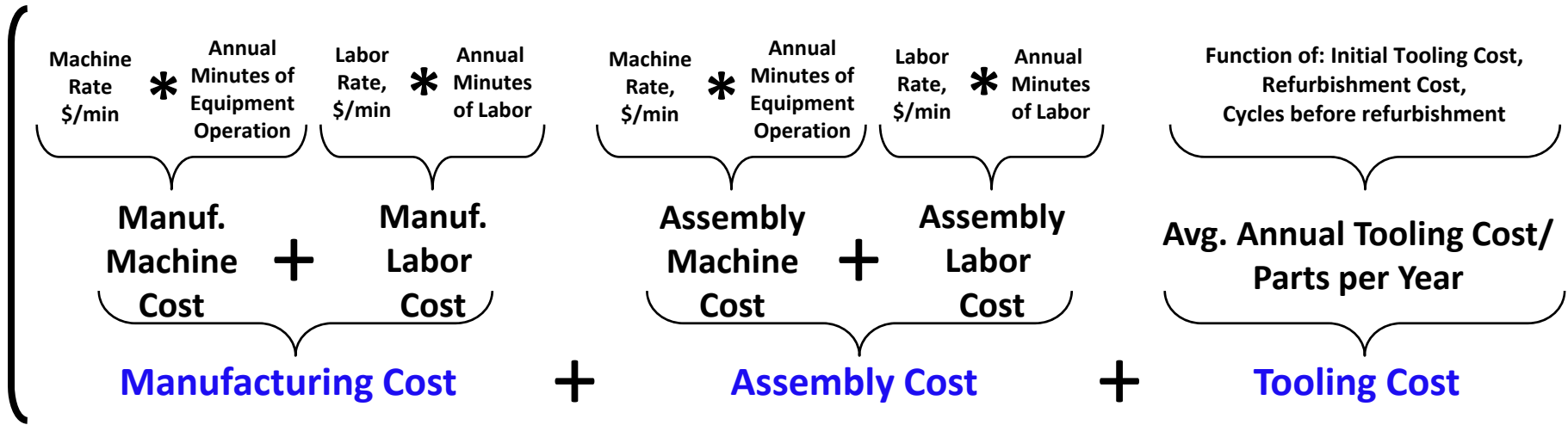

$$\text{Total Annual Cost} / \text{Units per Year} = \text{Cost per Unit}$$

Purchased Materials & Components

Fuel Cell Stack

Flow Plates (Injection Molding)

- Polypropylene
- Conductive Filler (Vulcan XC-72)

Flow Plates (Stamping)

- Stainless Steel 316L Sheet

MEA

Membranes

- ePTFE Substrate
- Ionomer

Cost of membrane determined by DFMA® analysis. Assumed to be purchased from supplier so Tier 1 markups are applied.

Catalyst Ink

- Carbon-Supported Platinum
- Chloroplatinic Acid
- Platinum
- Carbon Support (Vulcan XC-72)

CPA purchased from Tier 1 supplier. But Pt is supplied by OEM to avoid Tier 1 markup of the Pt. Analogous to precious metal purchases for catalytic converters.

Solvent

- Methanol
- DI Water
- Carbon Powder (Vulcan XC-72)

GDLs

Macroporous Layer

- Macroporous Substrate
- PTFE
- Solvent

Macroporous Substrate based on vendor quote with markup subtracted from quote to reflect OEM if made by OEM.

- Methanol
- DI Water

Microporous Layer

- Carbon Powder (Vulcan XC-72)
- PTFE
- Solvent

- Methanol
- DI Water

MEA Frame Gaskets

- Henkel Loctite LIM Hydrocarbon

End Gaskets

- Type A Resin

Endplates

- Thermoset Resin (LYTEX 9063)

Current Collectors

- Copper Sheet
- Copper Rod

Compression Bands

All materials and components listed in **red** are purchased from a tier 1 supplier, and thus include an ***implicit manufacturer markup***

Balance of Plant

Mounting Frames

[All Sub-Components]

Air Loop

Air Compressor, Expander, Motor

[All Sub-Components]

[All Other Sub-Components]

Humidifier & Water Recovery Loop

Air Humidifier Assembly

[All Sub-Components]

[All Other Sub-Components]

Coolant Loop (High Temp Loop & Low Temp Loop)

[All Sub-Components]

Fuel Loop

[All Sub-Components]

System Controller/Sensors

[All Sub-Components]

Miscellaneous BOP

Wiring

[All Sub-Components]

Belly Pan

[All Sub-Components]

[All Other Sub-Components]

Bill of Materials: Stack (2008 Technology)

Annual Production Rate	1,000	30,000	80,000	130,000	500,000
System Net Electric Power (Output)	80	80	80	80	80
System Gross Electric Power (Output)	90.23	90.23	90.23	90.23	90.23
Bipolar Plates (Stamped)	\$898.77	\$249.99	\$253.83	\$250.56	\$249.09
MEAs					
Membranes	\$2,829.02	\$499.02	\$313.29	\$246.74	\$132.43
Catalyst Ink & Application	\$880.36	\$659.52	\$653.29	\$651.79	\$642.12
GDLs	\$1,090.28	\$706.44	\$438.50	\$343.06	\$160.90
M & E Hot Pressing	\$38.63	\$9.33	\$9.18	\$9.42	\$9.16
M & E Cutting & Slitting	\$30.20	\$3.59	\$3.01	\$2.88	\$2.83
MEA Frame/Gaskets	\$137.90	\$247.03	\$241.37	\$239.85	\$233.07
Coolant Gaskets (Laser Welding)	\$94.31	\$19.51	\$15.03	\$14.00	\$14.14
End Gaskets (Screen Printing)	\$75.69	\$2.63	\$1.05	\$0.69	\$0.31
End Plates	\$69.90	\$37.97	\$34.02	\$31.74	\$23.85
Current Collectors	\$13.89	\$7.84	\$6.79	\$6.35	\$5.89
Compression Bands	\$10.00	\$8.00	\$6.00	\$5.50	\$5.00
Stack Assembly	\$39.56	\$20.82	\$17.91	\$18.31	\$17.84
Stack Conditioning	\$27.50	\$10.93	\$10.42	\$10.45	\$10.39
Total Stack Cost	\$6,236.02	\$2,482.61	\$2,003.70	\$1,831.35	\$1,507.03
Total Cost for All Stacks	\$12,472.04	\$4,965.23	\$4,007.39	\$3,662.69	\$3,014.06
Total Stack Cost (\$/kW_{net})	\$155.90	\$62.07	\$50.09	\$45.78	\$37.68
Total Stack Cost (\$/kW_{gross})	\$138.23	\$55.03	\$44.41	\$40.59	\$33.40

- 4.4 to 1 cost reduction between low and high manufacturing rates

Bill of Materials: Stack (2010 Technology)

Annual Production Rate	1,000	30,000	80,000	130,000	500,000
System Net Electric Power (Output)	80	80	80	80	80
System Gross Electric Power (Output)	86.71	86.71	86.71	86.71	86.71
Bipolar Plates (Stamped)	\$842.68	\$197.28	\$199.94	\$196.14	\$195.06
MEAs					
Membranes	\$2,304.36	\$415.97	\$257.01	\$200.55	\$104.31
Catalyst Ink & Application	\$760.44	\$547.76	\$541.92	\$539.16	\$531.73
GDLs	\$958.30	\$487.28	\$306.01	\$239.59	\$114.48
M & E Hot Pressing	\$38.01	\$7.52	\$7.67	\$7.71	\$7.55
M & E Cutting & Slitting	\$30.18	\$3.57	\$3.00	\$2.86	\$2.76
MEA Frame/Gaskets	\$241.26	\$166.11	\$162.09	\$160.96	\$156.32
Coolant Gaskets (Laser Welding)	\$93.59	\$13.30	\$12.56	\$12.38	\$12.11
End Gaskets (Screen Printing)	\$75.68	\$2.62	\$1.04	\$0.68	\$0.30
End Plates	\$53.09	\$25.63	\$23.62	\$21.55	\$16.49
Current Collectors	\$10.84	\$5.82	\$5.01	\$4.68	\$4.34
Compression Bands	\$10.00	\$8.00	\$6.00	\$5.50	\$5.00
Stack Assembly	\$39.56	\$20.82	\$17.91	\$18.31	\$17.84
Stack Conditioning	\$26.15	\$8.88	\$8.54	\$8.46	\$8.33
Total Stack Cost	\$5,484.13	\$1,910.58	\$1,552.34	\$1,418.55	\$1,176.63
Total Cost for All Stacks	\$10,968.26	\$3,821.15	\$3,104.68	\$2,837.09	\$2,353.26
Total Stack Cost (\$/kW_{net})	\$137.10	\$47.76	\$38.81	\$35.46	\$29.42
Total Stack Cost (\$/kW_{gross})	\$126.49	\$44.07	\$35.80	\$32.72	\$27.14

- 4.7 to 1 cost reduction between low and high manufacturing rates

Bill of Materials: Stack (2015 Technology)

Annual Production Rate	1,000	30,000	80,000	130,000	500,000
System Net Electric Power (Output)	80	80	80	80	80
System Gross Electric Power (Output)	87.06	87.06	87.06	87.06	87.06
Bipolar Plates (Stamped)	\$843.17	\$197.75	\$200.40	\$196.60	\$195.52
MEAs					
Membranes	\$2,310.61	\$417.98	\$258.26	\$201.53	\$104.83
Catalyst Ink & Application	\$567.75	\$368.67	\$364.24	\$361.84	\$356.89
GDLs	\$961.34	\$489.32	\$307.26	\$240.54	\$114.88
M & E Hot Pressing	\$38.01	\$7.53	\$7.67	\$7.71	\$7.55
M & E Cutting & Slitting	\$30.18	\$3.57	\$3.00	\$2.86	\$2.76
MEA Frame/Gaskets	\$242.10	\$166.81	\$162.78	\$161.64	\$156.98
Coolant Gaskets (Laser Welding)	\$93.60	\$13.30	\$12.56	\$12.39	\$12.11
End Gaskets (Screen Printing)	\$75.68	\$2.62	\$1.04	\$0.68	\$0.30
End Plates	\$53.24	\$25.73	\$23.72	\$21.64	\$16.56
Current Collectors	\$10.87	\$5.84	\$5.03	\$4.70	\$4.35
Compression Bands	\$10.00	\$8.00	\$6.00	\$5.50	\$5.00
Stack Assembly	\$39.56	\$20.82	\$17.91	\$18.31	\$17.84
Stack Conditioning	\$24.79	\$6.84	\$6.40	\$6.30	\$6.27
Total Stack Cost	\$5,300.90	\$1,734.78	\$1,376.28	\$1,242.25	\$1,001.83
Total Cost for All Stacks	\$10,601.79	\$3,469.55	\$2,752.55	\$2,484.49	\$2,003.67
Total Stack Cost (\$/kW_{net})	\$132.52	\$43.37	\$34.41	\$31.06	\$25.05
Total Stack Cost (\$/kW_{gross})	\$121.78	\$39.85	\$31.62	\$28.54	\$23.02

- 5.3 to 1 cost reduction between low and high manufacturing rates

Bill of Materials: Balance of Plant (2008 Technology)

Annual Production Rate	1,000	30,000	80,000	130,000	500,000
System Net Electric Power (Output)	80	80	80	80	80
System Gross Electric Power (Output)	90.23	90.23	90.23	90.23	90.23
Mounting Frames	\$100.00	\$43.00	\$33.00	\$30.00	\$30.00
Air Loop	\$2,616.69	\$1,364.16	\$1,063.94	\$954.11	\$803.28
Humidifier & Water Recovery Loop	\$535.13	\$379.81	\$315.54	\$300.75	\$273.77
Coolant Loop (High Temperature)	\$528.75	\$448.00	\$384.25	\$363.10	\$331.80
Exhaust Loop (Low Temperature)	\$169.18	\$147.40	\$130.32	\$123.28	\$113.90
Fuel Loop	\$927.50	\$747.00	\$566.50	\$528.40	\$457.20
System Controller/Sensors	\$300.00	\$245.00	\$230.00	\$222.00	\$200.00
Hydrogen Sensors	\$1,700.00	\$876.00	\$640.00	\$522.00	\$200.00
Miscellaneous	\$879.79	\$671.68	\$549.73	\$523.59	\$469.44
Total BOP Cost	\$7,757.03	\$4,922.05	\$3,913.28	\$3,567.24	\$2,879.39
Total BOP Cost (\$/kW_{net})	\$96.96	\$61.53	\$48.92	\$44.59	\$35.99
Total BOP Cost (\$/kW_{gross})	\$85.97	\$54.55	\$43.37	\$39.54	\$31.91

- 2.7 to 1 cost reduction between low and high manufacturing rates

Bill of Materials: Balance of Plant (2010 Technology)

Annual Production Rate	1,000	30,000	80,000	130,000	500,000
System Net Electric Power (Output)	80	80	80	80	80
System Gross Electric Power (Output)	86.71	86.71	86.71	86.71	86.71
Mounting Frames	\$100.00	\$43.00	\$33.00	\$30.00	\$30.00
Air Loop	\$1,887.03	\$1,327.82	\$1,003.72	\$891.74	\$754.33
Humidifier & Water Recovery Loop	\$900.00	\$600.00	\$425.00	\$350.00	\$250.00
Coolant Loop (High Temperature)	\$498.24	\$420.54	\$358.32	\$338.69	\$308.92
Exhaust Loop (Low Temperature)	\$0.00	\$0.00	\$0.00	\$0.00	\$0.00
Fuel Loop	\$927.50	\$747.00	\$566.50	\$528.40	\$457.20
System Controller/Sensors	\$300.00	\$245.00	\$230.00	\$222.00	\$200.00
Hydrogen Sensors	\$750.00	\$367.00	\$256.00	\$201.00	\$50.00
Miscellaneous	\$827.61	\$626.81	\$505.90	\$480.29	\$427.70
Total BOP Cost	\$6,190.38	\$4,377.17	\$3,378.45	\$3,042.12	\$2,478.14
Total BOP Cost (\$/kW_{net})	\$77.38	\$54.71	\$42.23	\$38.03	\$30.98
Total BOP Cost (\$/kW_{gross})	\$71.39	\$50.48	\$38.96	\$35.08	\$28.58

- 2.5 to 1 cost reduction between low and high manufacturing rates

Bill of Materials: Balance of Plant (2015 Technology)

Annual Production Rate	1,000	30,000	80,000	130,000	500,000
System Net Electric Power (Output)	80	80	80	80	80
System Gross Electric Power (Output)	87.06	87.06	87.06	87.06	87.06
Mounting Frames	\$100.00	\$43.00	\$33.00	\$30.00	\$30.00
Air Loop	\$1,378.48	\$969.57	\$728.45	\$651.05	\$553.20
Humidifier & Water Recovery Loop	\$0.00	\$0.00	\$0.00	\$0.00	\$0.00
Coolant Loop (High Temperature)	\$453.75	\$380.50	\$320.50	\$303.10	\$275.55
Exhaust Loop (Low Temperature)	\$0.00	\$0.00	\$0.00	\$0.00	\$0.00
Fuel Loop	\$927.50	\$747.00	\$566.50	\$528.40	\$457.20
System Controller/Sensors	\$300.00	\$245.00	\$230.00	\$222.00	\$200.00
Hydrogen Sensors	\$0.00	\$0.00	\$0.00	\$0.00	\$0.00
Miscellaneous	\$812.72	\$614.00	\$493.40	\$467.93	\$415.78
Total BOP Cost	\$3,972.45	\$2,999.07	\$2,371.84	\$2,202.48	\$1,931.73
Total BOP Cost (\$/kW_{net})	\$49.66	\$37.49	\$29.65	\$27.53	\$24.15
Total BOP Cost (\$/kW_{gross})	\$45.63	\$34.45	\$27.25	\$25.30	\$22.19

- 2 to 1 cost reduction between low and high manufacturing rates

Bill of Materials: System (2008 Technology)

Annual Production Rate	1,000	30,000	80,000	130,000	500,000
System Net Electric Power (Output)	80	80	80	80	80
System Gross Electric Power (Output)	90.23	90.23	90.23	90.23	90.23
Fuel Cell Stacks	\$12,472.04	\$4,965.23	\$4,007.39	\$3,662.69	\$3,014.06
Balance of Plant	\$7,757.03	\$4,922.05	\$3,913.28	\$3,567.24	\$2,879.39
System Assembly & Testing	\$158.84	\$114.18	\$112.24	\$112.39	\$112.01
Total System Cost	\$20,387.92	\$10,001.46	\$8,032.91	\$7,342.32	\$6,005.46
Total System Cost (\$/kW_{net})	\$254.85	\$125.02	\$100.41	\$91.78	\$75.07
Total System Cost (\$/kW_{gross})	\$225.96	\$110.85	\$89.03	\$81.38	\$66.56

- 3.4 to 1 cost reduction between low and high manufacturing rates

Bill of Materials: System (2010 Technology)

Annual Production Rate	1,000	30,000	80,000	130,000	500,000
System Net Electric Power (Output)	80	80	80	80	80
System Gross Electric Power (Output)	86.71	86.71	86.71	86.71	86.71
Fuel Cell Stacks	\$10,968.26	\$3,821.15	\$3,104.68	\$2,837.09	\$2,353.26
Balance of Plant	\$6,190.38	\$4,377.17	\$3,378.45	\$3,042.12	\$2,478.14
System Assembly & Testing	\$158.62	\$113.99	\$112.06	\$112.21	\$111.83
Total System Cost	\$17,317.25	\$8,312.32	\$6,595.19	\$5,991.42	\$4,943.23
Total System Cost (\$/kW_{net})	\$216.47	\$103.90	\$82.44	\$74.89	\$61.79
Total System Cost (\$/kW_{gross})	\$199.71	\$95.86	\$76.06	\$69.10	\$57.01

- 3.5 to 1 cost reduction between low and high manufacturing rates

Bill of Materials: System (2015 Technology)

Annual Production Rate	1,000	30,000	80,000	130,000	500,000
System Net Electric Power (Output)	80	80	80	80	80
System Gross Electric Power (Output)	87.06	87.06	87.06	87.06	87.06
Fuel Cell Stacks	\$10,601.79	\$3,469.55	\$2,752.55	\$2,484.49	\$2,003.67
Balance of Plant	\$3,972.45	\$2,999.07	\$2,371.84	\$2,202.48	\$1,931.73
System Assembly & Testing	\$158.62	\$113.99	\$112.06	\$112.21	\$111.83
Total System Cost	\$14,732.86	\$6,582.62	\$5,236.45	\$4,799.18	\$4,047.23
Total System Cost (\$/kW_{net})	\$184.16	\$82.28	\$65.46	\$59.99	\$50.59
Total System Cost (\$/kW_{gross})	\$169.24	\$75.61	\$60.15	\$55.13	\$46.49

- 3.6 to 1 cost reduction between low and high manufacturing rates