

# High Temperature Electrolysis System

Dr. Steve Herring  
Idaho National Laboratory  
May 19, 2009

Project ID #  
**PD\_14\_Herring**

# Overview

## Timeline

- Project start date:  
Jan. 2003, button cells
- Project end date:  
Engr. Demo (1 MW), 2015

## Budget

- Total project funding
  - All DOE-NE
- Funding received in FY08: \$3559k
- Funding for FY09: \$2588k

## Barriers

(MYPP p. 3.1-24)

- **G. Capital Cost** Development of larger systems is also needed to take advantage of economies of scale.
- **H. System Efficiency** New membrane, electrode and system designs are needed to improve system efficiency
- **I. Grid Electricity Emissions** Low-cost, carbon-free electricity generation is needed. Electrolysis systems that can produce both hydrogen and electricity need to be evaluated.

## Partners

- **Massachusetts Institute of Technology**
- **Ceramatec, Inc.**
- **St. Gobain Ceramics**
- **Materials & Systems Research, Inc.**
- **NASA – Glenn Research Center**
- **Argonne National Laboratory**
- **Virginia Tech, Georgia Tech (NERI projects)**
- **Project lead: Idaho National Laboratory**

# Relevance

- Objectives – Over Life of Project
  - Develop an economical method for the CO<sub>2</sub>-free production of hydrogen in centralized facilities
  - Configure the plant for the integration of heat and electricity from a nuclear reactor and for interactions with the grid to accept or supply power as wind/solar sources vary
- Objectives – June 2008 - May 2009
  - Construction and Operation of the three-module Integrated Laboratory Scale experiment for long-duration (>1000 hrs)
  - Organization and sponsorship of a Workshop on SOEC Degradation with experts from the SOFC/SOEC community
  - Characterization of degraded cells to determine silicon/chromium transport, delamination and destabilization of electrolyte
  - Tests of short stacks and button cells of other designs and from other manufacturers
  - Build capability to simultaneously run five small tests
  - Due to budget constraints, flowsheet modeling and CFD have been stopped for FY-09

# Relevance

## FY 2008 Milestones

- Demonstrate improved performance of oxygen and steam hydrogen electrodes through the deposition of electrocatalytic materials by the ALD or other infiltration processes. (ANL) 9/30/2008
- Test plan for ILS operations with three modules 5/15/2008
- Report on O<sub>2</sub> handling and cooling options based on collaboration with AECL 7/2/2008
- Three module test in the ILS at 15 kW input power. 9/15/2008
- Analysis report on corrosion testing of the second series of BOP materials 9/30/2008

## FY 2009 Milestones

- Long-term Operation of ILS [[Completed 10/20/08, 1080 hours](#)]
- Report on experimental data from the operation of the HTE ILS experiment (2/27/2009) [[Completed and uploaded to PICS 2/17/09](#)]
- Report on critical causes of stack degradation in ILS cells (5/29/2009)
- Report on long-term testing of 10-cell stacks degradation (8/14/2009)
- Complete 2500 hr 10-cell stack test (9/14/09)
- Report on insights gained from testing of alternative cell designs (9/15/2009)

# Approach

- Develop energy-efficient, high-temperature, solid-oxide electrolysis cells (SOECs) for hydrogen production from steam.
  - Optimize energy efficiency, cost and durability
    - optimize electrolyte materials (e.g., YSZ, ScSZ, sealants)
    - investigate alternate cell configurations (e.g., electrode-supported or tubular)
- Develop and test integrated SOEC stacks operating in the electrolysis mode with an aim toward scale-up to a 200 kW Pilot Plant and a 1 MW Engineering Demonstration Facility
  - Increase SOEC stack durability and sealing with regard to thermal cycles
  - Improve material durability in a hydrogen/oxygen/steam environment
  - Perform a progression of electrolysis stack testing activities at increasing scales and complexities
  - Develop computational fluid dynamics (CFD) capability for SOEC
  - Utilize advanced systems modeling codes (e.g. HYSYS, ASPEN)
  - Perform Cost and Safety Analyses

# High-Temperature Electrolysis (HTE) Research and Development Activities at INL

## Button Cell

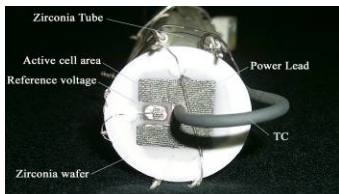

## Short Stacks

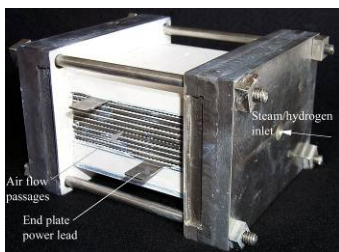

70 NL/hr

## CFD

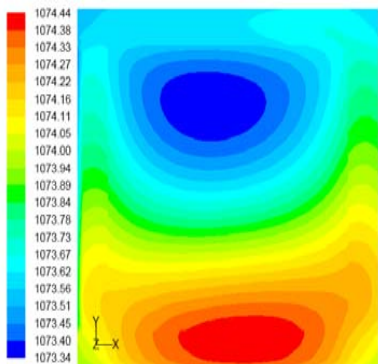

## Integrated Laboratory Scale Facility



INL has demonstrated H<sub>2</sub> production rates up to 5.6 Nm<sup>3</sup>/hr in the ILS facility

## Alternate Configuration Testing



## Flowsheet Modeling

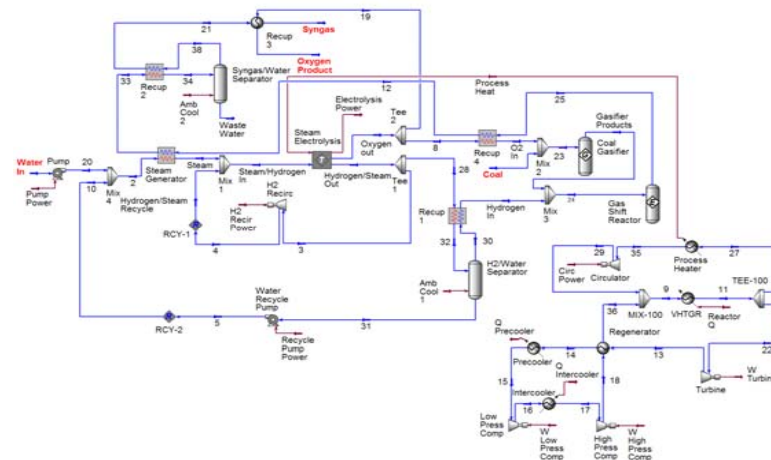



# Technical Accomplishments and Progress, 2008

- Three-module operation of the High Temperature Electrolysis Integrated Laboratory Scale experiment (level 1 due Sept 15, 2008)
  - Max. H<sub>2</sub> Production: 5.65 Normal m<sup>3</sup>/hour (0.504 kg H<sub>2</sub>/hr, 18 kW)
    - 50x higher max. production, 6x longer than competing methods
    - Major issue: long-term cell degradation
  - Operated 24-7 Sept 5 to Oct 20, 1080 hours
  - Incorporated Heat Recuperation and H<sub>2</sub> Recycle



Three Modules, 4x60 cells each

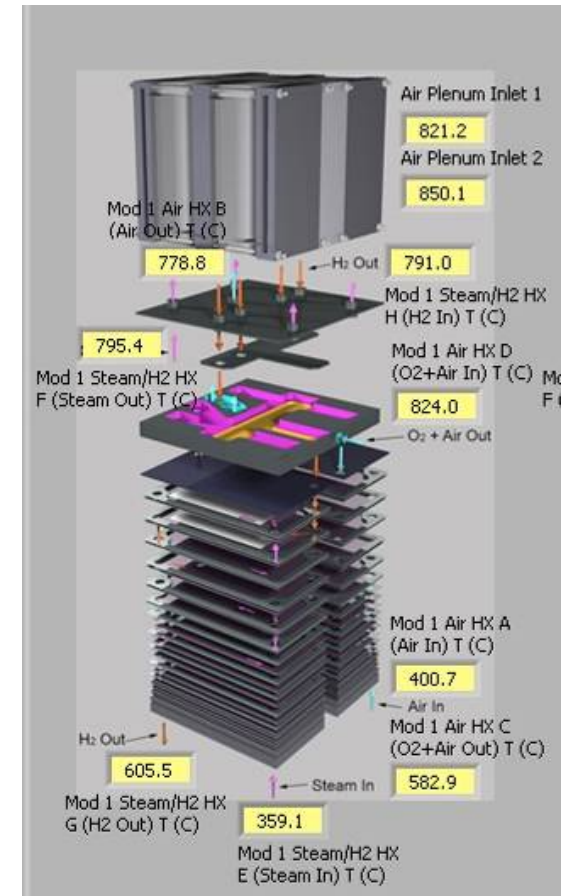

Heat Recuperator (1 of 3)

# Technical Accomplishments and Progress, 2008

## NASA-Glenn (Cable and Sofie) freeze tape casting SOEC testing

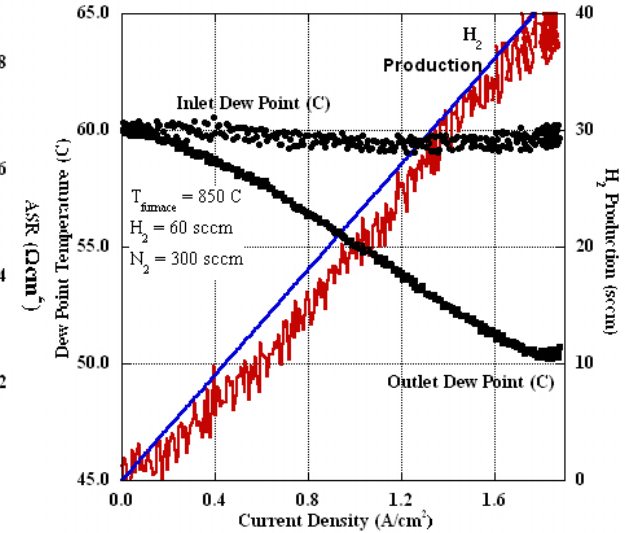
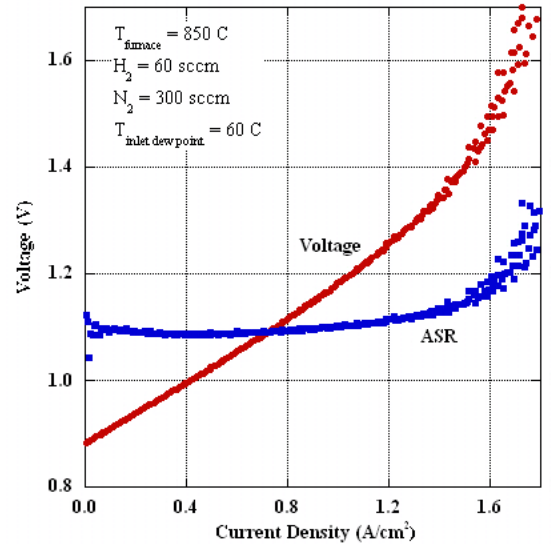
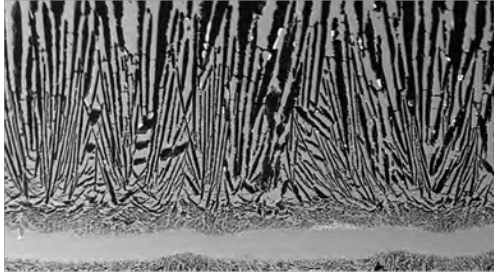

Use of FeCrAlloy for the inlet and outlet manifolds of the three-module test eliminated the corrosion seen in the half-module test. Use of 446SS in single-module test also reduced manifold corrosion.



## Testing of 20 x 20 cm Ceramatec stacks

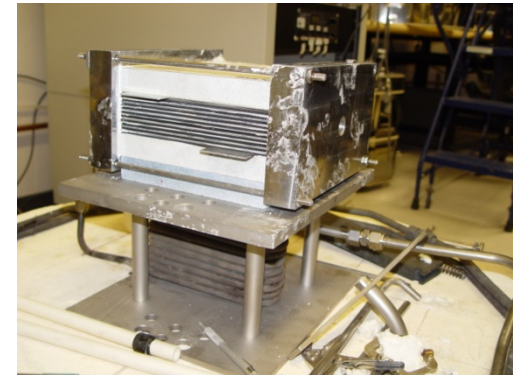



# Immediate Challenge: Long-term Cell Degradation

*Cell increases in resistance while operating at constant voltage, leading to a decrease in H<sub>2</sub> production.*

## Possible causes:

- Chromium transport to electrodes from interconnects
- Silicon transport to electrodes from sealants
- Changes in electrolyte morphology due to transport of yttria or scandia
- Delamination due to limited O<sub>2</sub> formation at the electrolyte-electrode interface

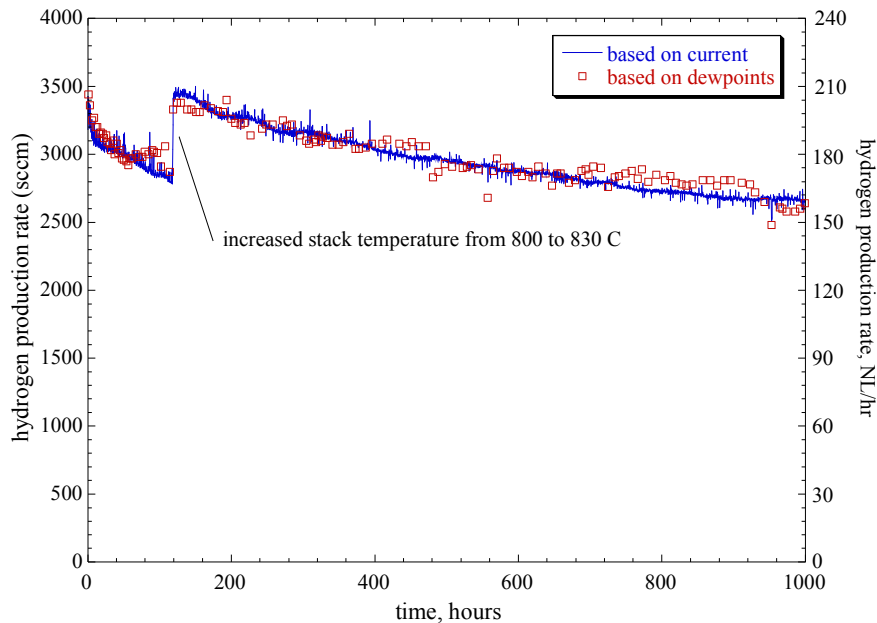

Jan-Feb 2006 25-cell test:  
rate: 21%/1000 hours

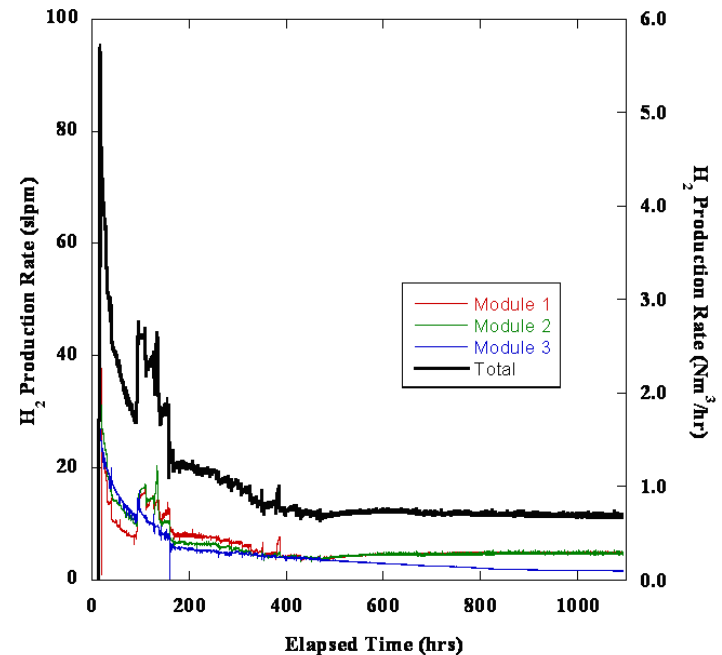

ILS Three Module Operation  
Sept-Oct 2008  
At 480 hrs the H<sub>2</sub> recycle was fixed

# Degradation studies roadmap

Testing of fully stabilized ScSz and YSZ electrolyte performance

Investigation of degradation mechanisms in SOEC Oxygen electrodes

Bond Layer Dissociation

Interdiffusion of Cr-containing species from interconnects into bond layer and anode

Cation segregation

Local variations in cation ratios at catalyst surface

Cr distribution across the bond layer and anode

Relationship between Cr and local composition

- Cation interdiffusion between cathode and electrolyte of SOFCs

- Presence of Cr-containing species in SOFC cathode

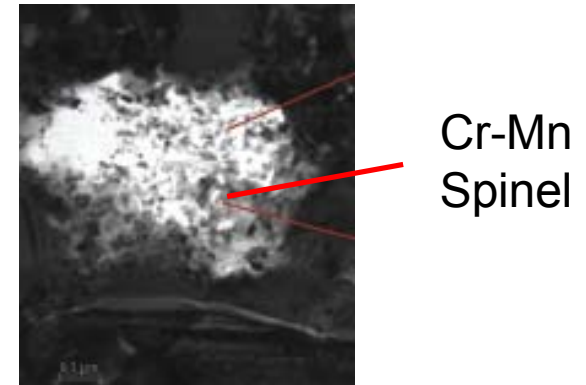
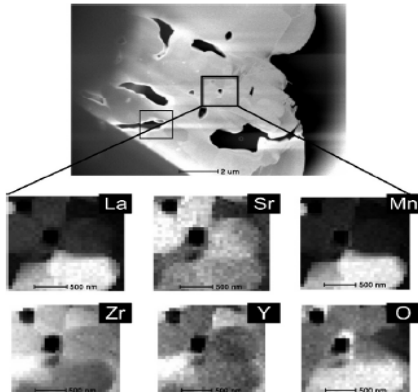

# Degradation Characterization

| Technique   | Objective   |
|---|---|
| Raman Spectroscopy  | Preliminary identification of <b>secondary phases formed</b> on the surface of the bond layer   |
| Nanoprobe Auger Electron Spectroscopy (NAES)                                      | Electrode <b>surface chemistry and microstructure</b> and its variation across the cross section at a small scale ( $\mu\text{m}$ - $\text{nm}$ ) |
| Focused Ion Beam (FIB)  | <b>Selectively choose the interface of interest</b> to prepare <b>TEM samples</b> from  |
| Energy Dispersive X-Ray Spectroscopy (EDX)/Transmission Electron Microscopy (TEM) | <b>High resolution</b> identification of the <b>chemical composition and secondary structures</b> formed  |

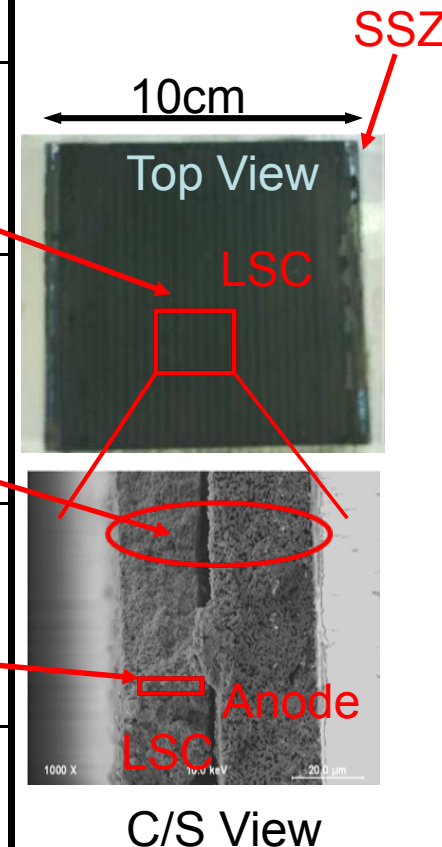

# Collaborations

- INL Sponsored International Workshop on Degradation, October 2008, with 25 experts on SOFC and SOEC degradation mechanisms. Using output of workshop to guide further development and testing
- Ceramatec, Inc., Salt Lake City: development and manufacture of electrolyte-supported cells used in the Integrated Laboratory Scale experiments in 2007 and 2008
- MIT: analysis of cells to determine causes of degradation, particularly of oxygen electrode
- Argonne National Laboratory: post-test analysis of cells
- Virginia Tech: development and analysis of sealant glasses (NERI)
- Georgia Tech: development of porosity-gradient oxygen electrodes (NERI)
- University of Arizona: summer student
- NASA-Glenn: testing of all-ceramic stack concept
- MSRI, VersaPower and St. Gobain: testing of their hydrogen-electrode-supported SOFC designs in electrolytic mode

# Future work for FY-09

*Emphasis: Improve long-term SOEC performance*

- **Finish expansion of INL testing lab to allow parallel testing of up to five experiments**
  - **allowing for accelerated studies of degradation**
- **Participate in Karlsruhe (EIFER) workshop on HTSE degradation. June '09**
- **Conduct tests on button cells and stacks during FY-09 of various designs from various vendors (MSRI, St. Gobain, VersaPower, NASA,..)**
- **Ceramatec: Transition to use of a fully stabilized scandia-zirconia electrolyte**
- **Ceramatec: Explore advanced electrode materials**
- **Examine cells using Auger and Raman spectroscopy**
  - determine elemental transport and changes in morphology**
- **Collaborate with SECA SOFC manufacturers to determine why SOFC degradation rates are ~10x lower**
- **Experimentally adjust average steam concentration within cells to determine if drier gas conditions (~SOFC conditions) result in slower degradation**
- **Experiment with coatings on the interconnect to prevent Cr transport**



# Future work for FY-10

Major assumption: HTSE is chosen to go forward for development with the NGNP

**Design of pilot plant**

**Pressurized operation - will require development work**

**Experimental and computation efforts**

**Develop heat integration with the NGNP**

**Flowsheet analysis**

**Development of heat exchangers**

**Initiate down-selection of potential SOEC vendors**

**Continue improvement of long-term SOEC performance**

**Continue study of SOEC for synthesis of liquid fuels as well as for production of hydrogen for end-use needs**

# Summary

- Constructed and operated the Integrated Laboratory Scale experiment with a full set of modules for 1080 hrs in Sept.-Oct. 2008
  - Automated, integrated platform; unattended operation
  - Heat recuperation
  - Hydrogen recycle
  - Little corrosion of manifolds (new manifold material)
- Major issue with the degradation of cells – possible causes:
  - Chromium transport to electrodes from interconnects
  - Silicon transport to electrodes from sealants
  - Changes in electrolyte morphology due to transport of yttria or scandia
  - Delamination due to limited O<sub>2</sub> formation at the electrolyte-electrode interface
- Focus in FY-09
  - Long-term short stack and button-cell testing
  - Testing of cells from additional manufacturers
  - Detailed characterization of processes in electrolytic cells
    - Nanoscale Auger and Raman scans of electrodes and electrolyte
    - Sectioning at the interfaces to determine migration