

Hydrogen and Fuel Cell Technology Education Program (HFCT)

PI: David L. Block

University of Central Florida

Co PI: Ahmad K. Sleiti

University of North Carolina Charlotte

May 10, 2011

Project ID: ED006

This presentation does not contain any proprietary, confidential, or otherwise restricted information



Overview

Timeline

- **Project start date: 08/2008**
- **Project end date: 09/2011**
- **Percent complete: 90%**

Budget

- **Total project funding**
 - DOE share: \$399K
 - Cost share: \$100K
- **Funding received in FY10-FY11**
 - None

Barriers

- **Technical barriers /Relevance**
 - A. Lack of Readily Available, Objective, and Technically Accurate Information
 - B. Mixed Messages, confusion about technology readiness
 - D. Lack of Educated Trainers and Training Opportunities
- **Technical accomplishments**
 - Develop concentration in HFCT
 - Outreach plan and recruiting
 - Industrial collaboration
 - Program sustainability

Partners

- **Florida Solar Energy Center (FSEC)**
- **University of Central Florida (UCF)**
- **University of North Carolina Charlotte (UNCC)**



Outline

- Project Relevance/Outcomes
- Key Results and Accomplishments
- UNCC Program
- Collaborations
- Future Work
- Responses to Reviewers



Relevance/Outcomes

Objectives

- **Develop and sustain Hydrogen and Fuel Cell Technology (HFCT) education concentration.**
- **Offer HFCT courses and associated labs.**
- **Develop industry and educational collaborations.**

Outcomes

- **Prepare students to work successfully as HFCT professionals.**
- **Demonstrate student knowledge, techniques, skills, and modern tools related to HFCT.**



Key Results

- All HFCT courses developed and offered
- All laboratories experiments developed and offered
- Program concentration implemented in populated engineering program at UNCC
- Industry collaborations established
- Program is part of national HFCT educational network
- Program positioned for continuation



Accomplishments

Project Milestones	% Complete	Comments	Progress Notes
Developing courses for HFCT concentration	100%	All new courses were developed, including syllabi, textbooks and schedule	The new courses were integrated in the program. HFCT courses are part of energy concentration in ME
Offering courses for HFCT concentration	100%	All courses are available for students	Existing courses offered
Labs	100%	All labs developed	Labs offered as part of the courses offered
Promoting the program and outreach plan and recruiting	95%	Ongoing activities	HFCT presented at student information sessions. Promoted through EPIC
Establish collaborations	95%	Meeting with NC industry	Meetings held. Industry members on advisory boards



HFCT Course Offering Matrix

COURSE	PREFIX	CREDIT HOURS	OFFERED	FUTURE OFFERING
Applied Energy Systems	ETM 4220	3	Spring 2009	Spring 2011
Analysis of Renewable Energy	ETGR 3000-01 and ETME 4250	3	Spring 2010	Spring 2011
Combined Hydrogen Production & Storage with Labs	ETGR 3000-02, MEGR 3090-020 and ETME 4260	3	Summer 2010	Summer 2011
Lab 1: Hydrogen and Fuel Cell Lab	Part of ETGR 3000	-	Summer 2010	Summer 2011
Lab 2: Hydrogen as a Energy Carrier	Part of ETGR 3000	-	Summer 2010	Summer 2011
Lab 3: Methanol Fuel Cells	Part of ETGR 3000	-	Summer 2010	Summer 2011
Fuel Cell Tech 1	ETGR 3000-M01 MEGR 3090-M03	3	Fall 2010	Fall 2011
Lab 1: Assembly MEA FC	Part of ETGR 3000	-	Fall 2010	Fall 2011
Lab 2: Fuel Cell Performance	Part of ETGR 3000	-	Fall 2010	Fall 2011
Lab 3: FC Performance as function of temp.	Part of ETGR 3000	-	Fall 2010	Fall 2011
Senior Design Course	MEGR 3255-001 ETGR 4100-EC1	6	Fall 2010	Fall 2011

Senior Design Projects

USES OF HYDROGEN

Hydrogen is the most abundant element on earth. The future of renewable energy lies in making this element available for energy use.

Progress Energy H₂ Bus Project

Progress Energy has teamed up with Ford to produce a V-10, E-450 bus designed specifically for internal combustion of H₂. These 12-passenger shuttle busses transport visitors around the Orlando airport and get a range of up to 150 miles and near-zero emissions.



Ford PEM Fuel Cell Vehicle

Through innovation of Progress Energy and Ford Motor Company, a fuel cell vehicle was born. This car features a 4 kg H₂ tank giving it a range of 200 miles with H₂O as the only emission.



Reverse Hydrogen Fuel Cell Group

EJ Naimaster
ej.naimaster@gmail.com

Max Biggar
rmbiggar@gmail.com

Dane Windsor
dane.windsor@gmail.com

Steve Kaspick
stevo585@hotmail.com

Technical Advisor:
Dr. Ahmad Sleiti
asleiti@mail.ucf.edu



This work is based on material supported by Progress Energy and the US Department of Energy, Office of EERE, under Award Number [DE-FG36-08GO18109].

REVERSE HYDROGEN FUEL CELL GROUP AMMONIA ELECTROLYSIS CELL (AEC) SYSTEM

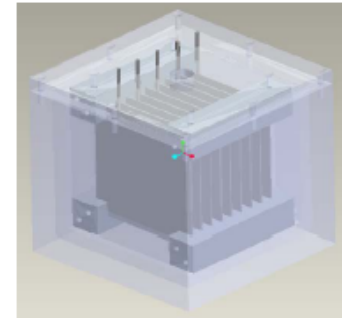
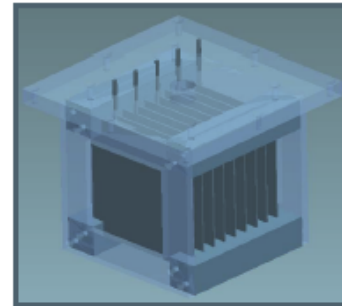

Student Reaction to HFCT Courses

- Data available through the course evaluation forms and Individual Course Assessment Process reports
- HFCT program is part of an ABET accredited program that has assessment processes and tools



University of North Carolina, Charlotte

- University
 - Located in NC largest metropolitan area
 - 26,000 students
 - 40,000 students by 2015
 - 3,000 full- and part-time employees
- Lee College of Engineering – 4,000 students
 - ME Department - 900 students, 42 Faculty
 - ET Department - 850 students, 35 Faculty



University of North Carolina, Charlotte

Lee College of Engineering at UNCC:

- A total enrollment of about 4,000 students.
- Scholarships, more than 30 student chapters, professional organizations.
- Co-Op, work-study, and internships available with industry leaders.
- Department, college and faculty labs.
- Hydrogen and fuel cell lab.



Energy Production & Infrastructure Center

- HFCT courses are available to EPIC
- More than \$400K provided by EPIC for HFCT lab and Thermophysics lab
- Funding support for 2 graduate students to work on HFCT
- Outreach through EPIC website and activities
- Duke Energy and Siemens Energy announced support of \$8.8 million, January 2011

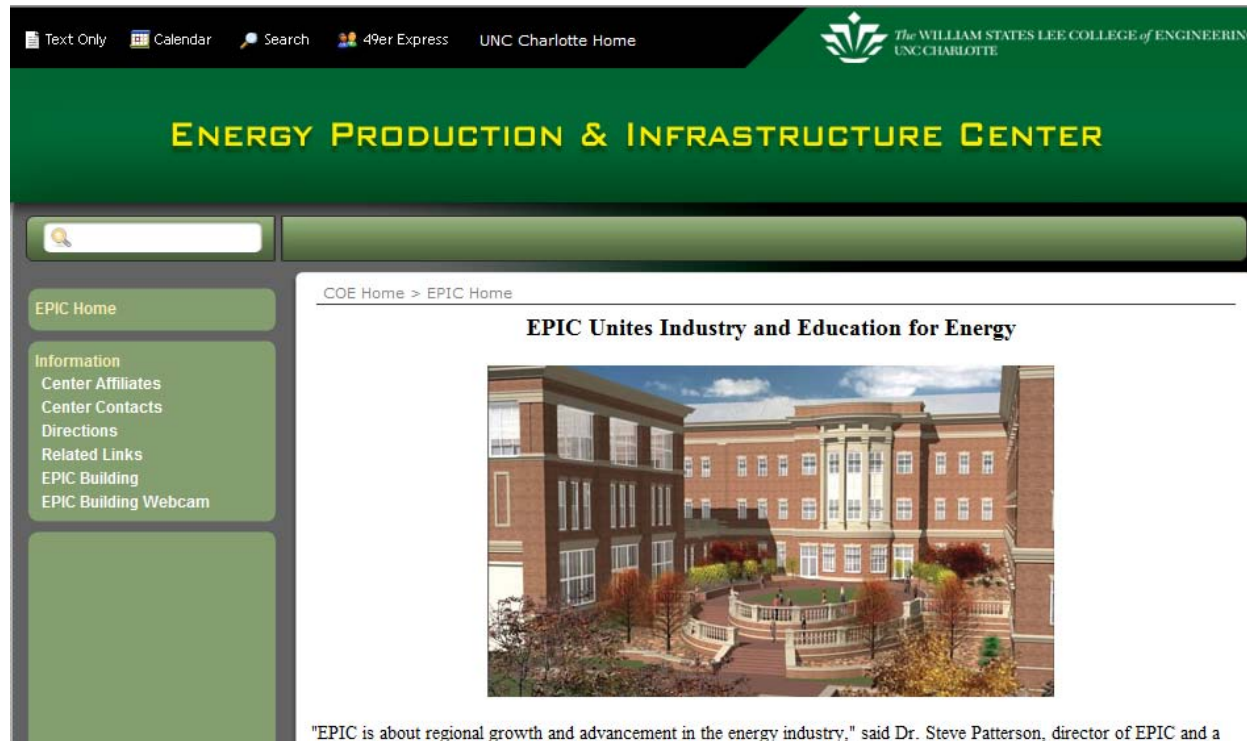

The screenshot shows the website for the Energy Production & Infrastructure Center (EPIC) at The William States Lee College of Engineering, UNC Charlotte. The page features a green header with the center's name in yellow. Below the header is a search bar and a navigation menu. The main content area displays the title "EPIC Unites Industry and Education for Energy" above a photograph of a large, multi-story brick building with a central courtyard. The building has a prominent white portico with columns. The courtyard is surrounded by trees and a low wall. The website also includes a sidebar with links to "EPIC Home", "Information", "Center Affiliates", "Center Contacts", "Directions", "Related Links", "EPIC Building", and "EPIC Building Webcam".

Text Only | Calendar | Search | 49er Express | UNC Charlotte Home

The WILLIAM STATES LEE COLLEGE of ENGINEERING
UNC CHARLOTTE

ENERGY PRODUCTION & INFRASTRUCTURE CENTER

COE Home > EPIC Home

EPIC Unites Industry and Education for Energy

"EPIC is about regional growth and advancement in the energy industry," said Dr. Steve Patterson, director of EPIC and a

University of North Carolina, Charlotte

North Carolina Motorsports and Automotive Research Center (NCMARC):

- One of the most innovative "hands-on" educational experiences
- Alternative transportation energy

Infrastructure, Design, Environment and Sustainability Center (IDEAS):

- Mission is to help frame the challenges; provide the leadership, and create solutions that will accelerate the technological and cultural shifts needed to make our built environment more sustainable.



Collaborations

- **Savannah River National Lab**
- **NC Hydrogen Economy and Advancement Team (HEAT)**
- **NC Fuel Cell Alliance**
- **The Advanced Vehicle Research Center of North Carolina**
- **North Carolina Energy Office Programs**
- **Duke Energy**
- **AREVA**
- **EPRI**
- **Shaw Group**
- **Siemens**



Future Work

- Continue offering HFCT courses and labs
- Continue recruitment of students
- Continue industry and educational collaborations
- Develop web based HFCT courses
- Extend to MS program with HFCT courses
- Develop research component



Summary

Relevance: Develop, present and continue Hydrogen and Fuel Cell Technology (HFCT) education concentration.

Approach: Develop new HFCT courses and labs, teach courses, integrate HFCT option into existing engineering programs, recruit freshmen, AS and AA students, use existing labs and resources, engage other UNCC centers in program, disseminate and publish HFCT results, conduct HFCT research.

Technical Accomplishment and Progress: HFCT courses offered successfully, student enrollment good, Hydrogen and Fuel Cell lab developed and equipped, Thermodynamics and Heat Transfer labs are used by HFCT program, senior design projects offered, established internal and external collaborations, conducted visits to community colleges and high schools, students are recruited, dissemination and publications ongoing.

Collaborations: Partnering and collaborating with other UNCC centers; EPIC, NCMARC, IDEAS. Established collaborations with SRNL, EPRI and with industries. Industry serve on advisory board.



The End

Thank you!

