

Oil-Free Centrifugal Hydrogen Compression Technology Demonstration

PI: Hooshang Heshmat, PhD
Mohawk Innovative Technology, Inc.
May 10, 2011

Project ID #
PD016

Overview

2

Timeline

- Start Sept 1, 2008
- Funding Authorized 2/28/09
- End Aug 31, 2011
- Ext. Requested to Aug 2012
- 48 % Complete

Budget

- Total Project Funding
 - \$2,992,407 DOE
 - \$1,149,253 MiTi/MHI Cost Share
- \$346,208 FY10 Funding
- \$720,000 FY11 Funding

Barriers

- Hydrogen Delivery Compressor
 - Reliability
 - System Cost
 - Efficiency of H₂ Gas Compression

Partners

- Lead: Mohawk Innovative Technology, Inc. 
 - Albany, NY
- Mitsubishi Heavy Industry 
 - Hiroshima, Japan

Project Objectives

3

- Relevance

Design a reliable and cost effective centrifugal compressor for hydrogen pipeline transport

- Flow 240,000 to 500,000 kg/day
- Pressure Rise to 300-500 psig up to 1,200-1,500 psig
- Contaminant-Free/Oil-Free Hydrogen

Category	2005 Status	Project Target	
		FY2012	FY2017
Reliability	Low	Improved	High
Energy Efficiency	98%	98%	>98%
Capital Investment (\$M) (based on 200,000 kg of H ₂ /day)	\$15	\$12	\$9
Maintenance (% of Total Capital Investment)	10%	7%	3%
Contamination	Varies by Design		None

Compressor Design Methodology

4

- Approach

✓ Compressor Design Analysis

- Mean Line Analysis, CFD, FEA

✓ Sub-Component Design

- Foil Bearings & Seals
- Coatings

✓ Design Single-Stage

- Impeller, Diffuser and Others
- Drive System & Test Loop

□ Single Stage Proof Testing

- Fabricate & Characterize Pressure & Flow

□ Scale System Design

- Predict Complete System Performance
- Update Multi-Stage, Multi-Frame Design
- Economic Analysis

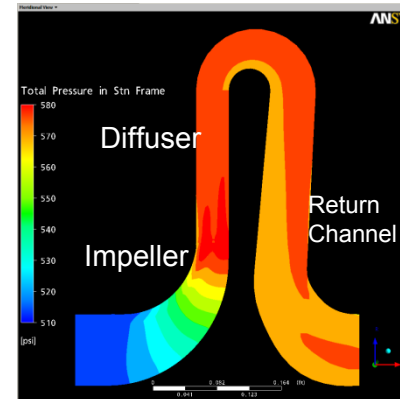
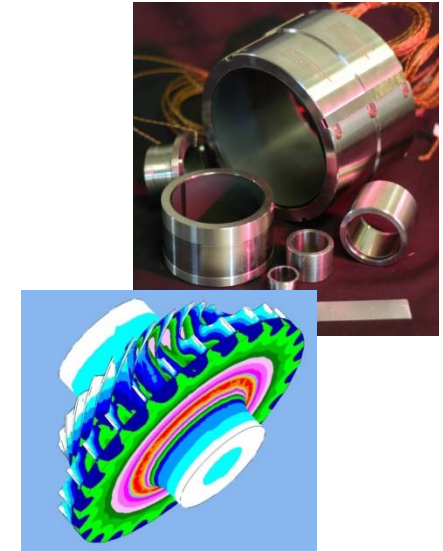
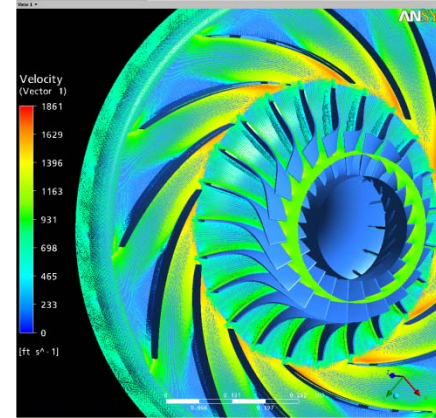

Demonstrate feasibility of very high speed hydrogen centrifugal compressor

MiTⁱ® Foil Bearings – Operational Concept

5

- Approach

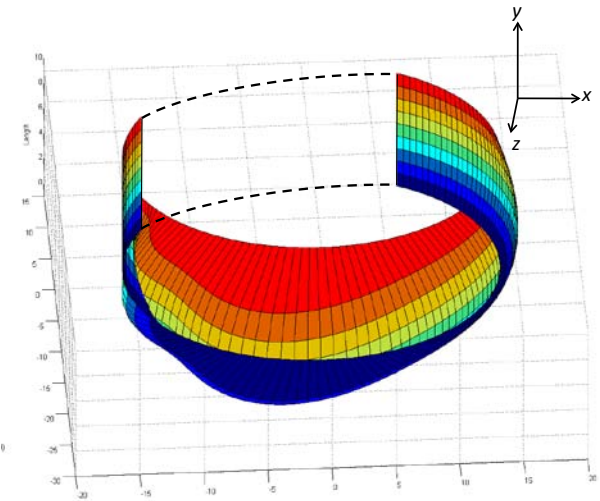
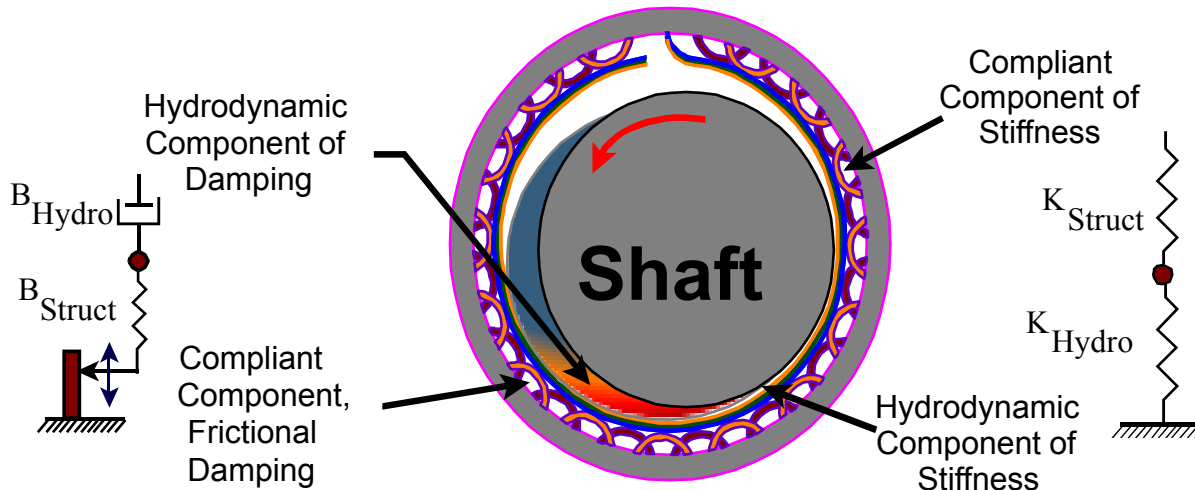
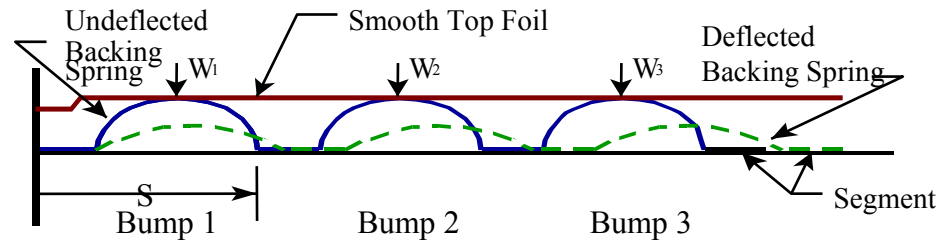
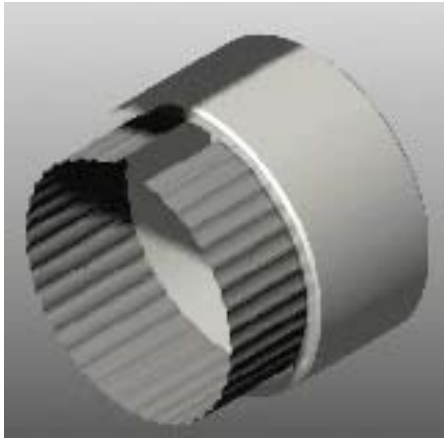

Predicted Profile

Compliant Foil Seals

6

- Approach

- Derived From MiTi's Foil Bearing Technology
- Both Face and Shaft Sealing Available
- Non-Contacting
- Capable of Accommodating Large Excursions and Extreme Environments
- Very Low Leakage Compared to State-of-the-Art Sealing Alternatives*

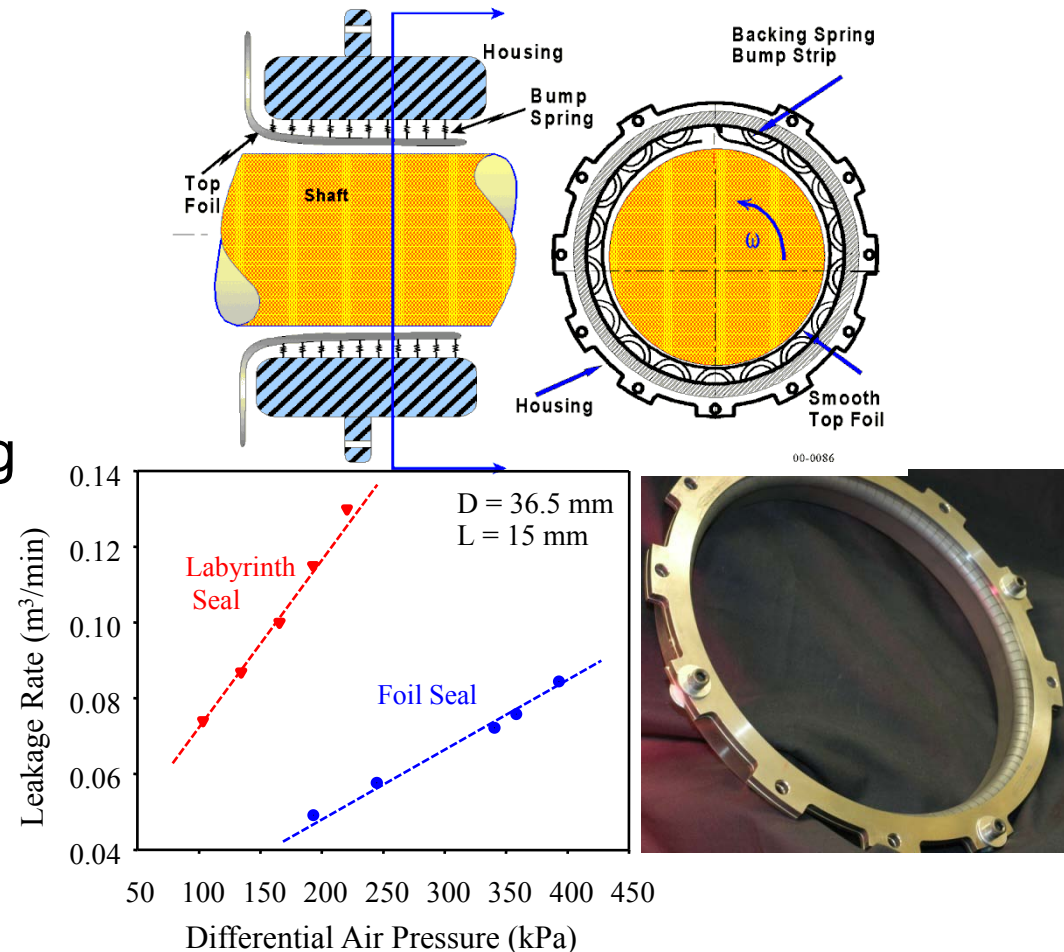

* Salehi, M. and Heshmat, H. "High Temperature Performance Evaluation of a Compliant Foil Seal," Paper No. AIAA 2000-3376, Proceedings of the 36th Joint Propulsion Conference and Exhibit, July 16-19, 2000, Huntsville, Alabama.

MiTi Korolon® Coatings

7

- Approach

Successful Operation of Foil Bearings/Seals Require Solid Lubricant Coatings
 Korolon® Coatings Have Been Specifically Designed for Foil Bearings/Seals



Flexible Ceramic Coating

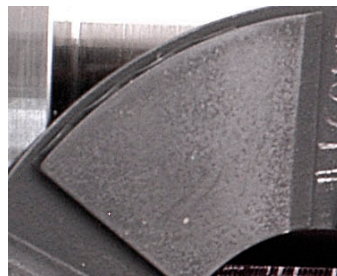

New Foil Pad

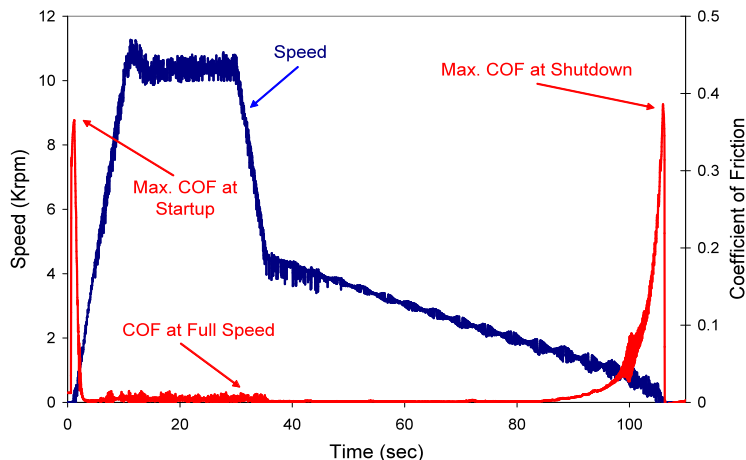

Typical Friction/Speed Results Showing Hydrodynamic Lift

	Korolon® 700	Korolon® 800 & 900	Korolon® 1350 A & B
Chemical Composition	Polymer based with solid lubricants	Tungsten Disulfide based with solid lubricants	Nickel-Chrome with solid lubricants
Service Temperature	Up to 700 °F	Up to 900 °F	200-1350°F

- Low Friction and Wear Rate
- Deposited with Spray Gun Process at Room Temp

Recent Research Has Shown That Polyamide Coatings, Such as Korolon®, are Compatible With H₂ [Int'l Hydrogen Energy Development Forum, Fukuoka, Japan 2011]

MiTi Compressor Design Analysis

8

- Technical Accomplishments & Progress

- Double-Entry Multi-Frame Compressor
 - 6 and 9 Stages (2 and 3 Frames)
- Exit Pressure > 1,200 psi
- Power: 7,800 – 12,000 HP
- Tip Speed: 1,500 – 2,000 ft/s
- Mass Flow: 240K – 500K kg/day
- Max Bearing/Seal Temp: 180-200°F
- Specific Energy: 0.48-0.59 ($\frac{\text{kW-HR}}{\text{Kg}}$)

Single Frame

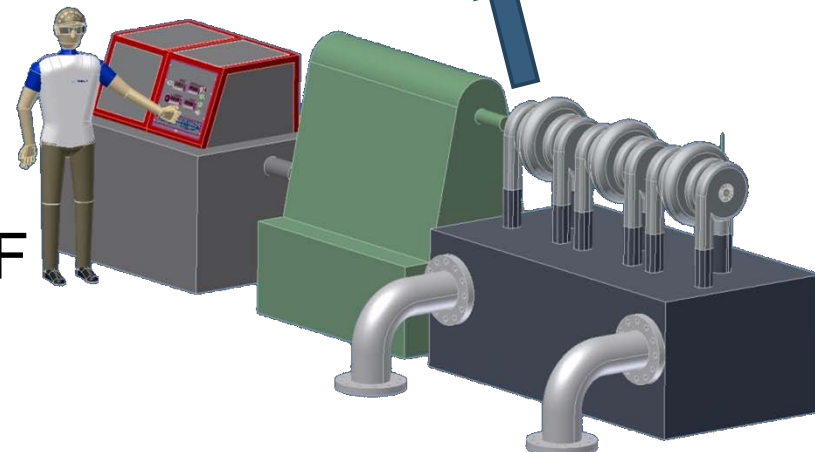
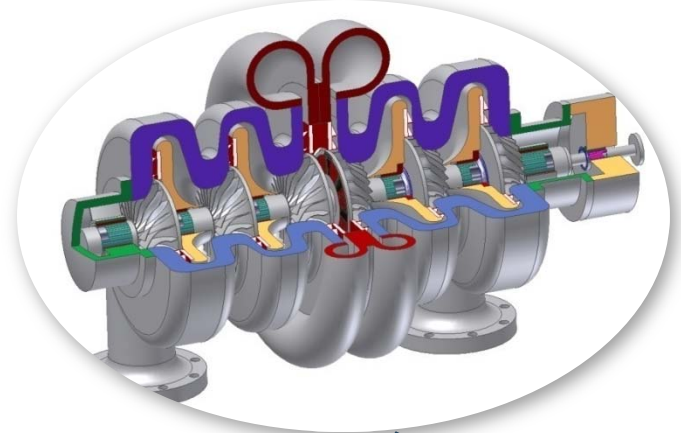

Fully Assembled, 3-Frame System

Mitsubishi Compressor Design Analysis

9

- Technical Accomplishments & Progress

- ❑ Single-Entry Multi-Frame Compressor
 - 7 and 9 Stages (2 and 3 Frames)
- ❑ Design Developed by MHI with Input from MiTi
- ❑ Bearing/Rotor Design Analysis Performed by MiTi
- ❑ Design Based on NG Pipeline Compressors
- ❑ Exit Pressure: > 1,200 psi
- ❑ Power: 8,300 - 12,000 HP
- ❑ Tip Speed: > 2,000 ft/s
- ❑ Mass Flow: 240K – 500K kg/day
- ❑ Specific Energy: 0.44-0.65 ($\frac{\text{kW-HR}}{\text{Kg}}$)

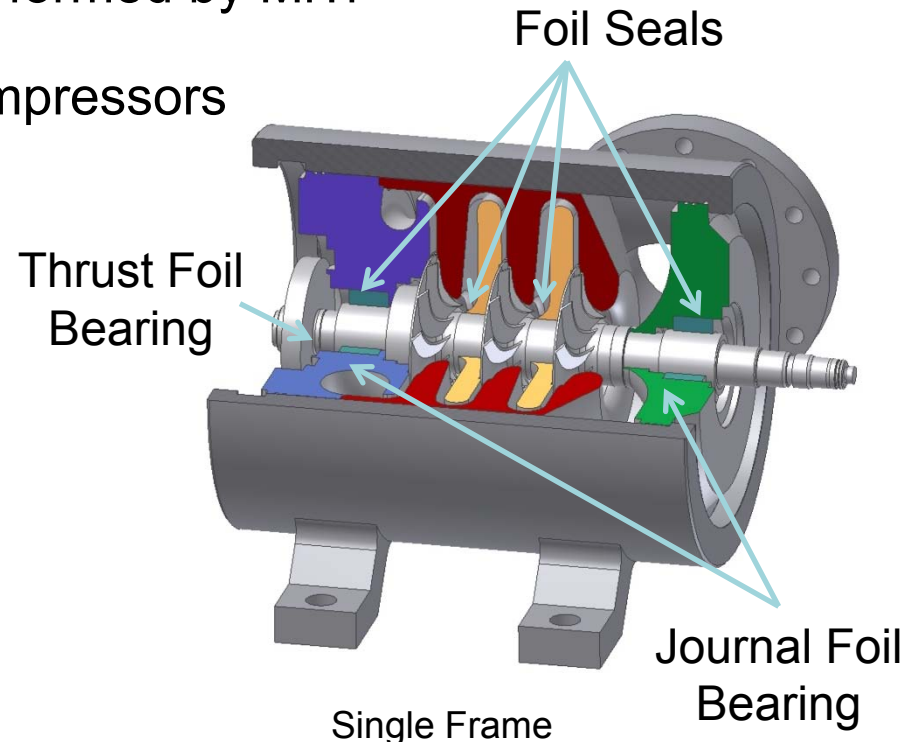

Multi-Stage Compressor Design

10

- Technical Accomplishments & Progress

- MiTi - Double-Entry
- MHI - Single-Entry
- Excellent Correlation Between the Two Designs Within the Operating Range

Design Comparison: No. Stages vs. Tip Speed for Three Different Pressure Ratios

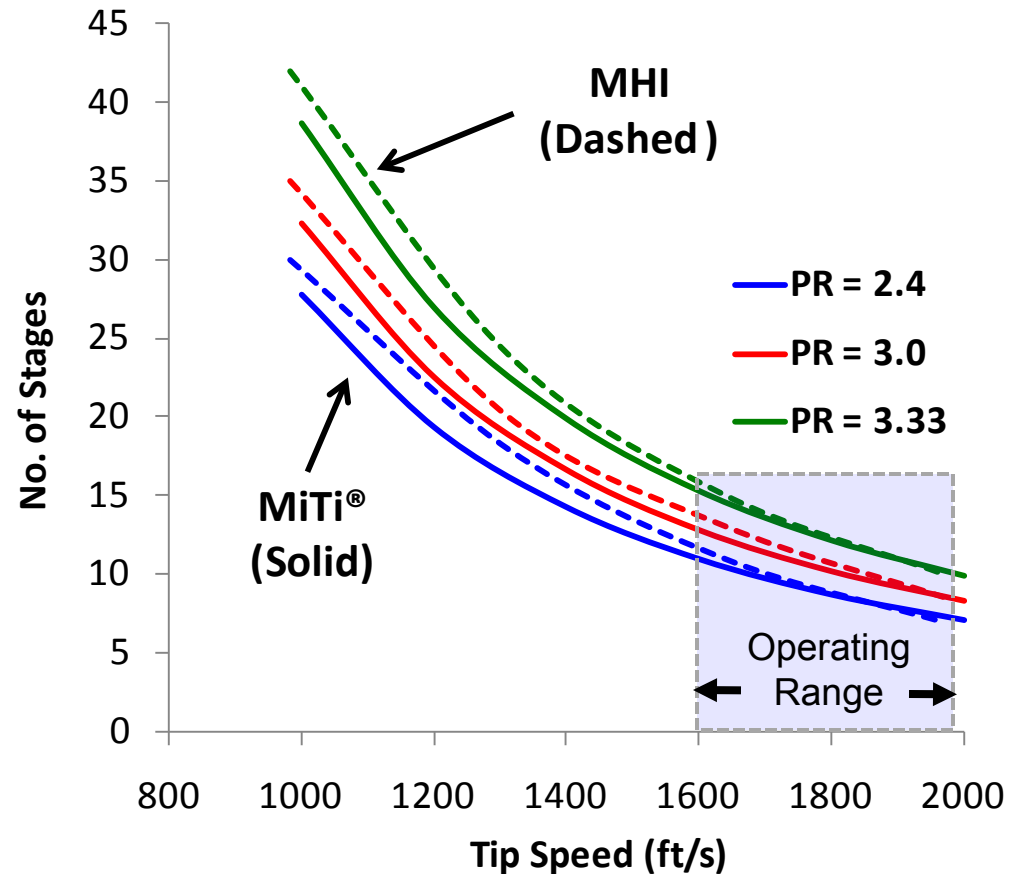

Rotor/Bearing System Dynamics

11

- *Technical Accomplishments & Progress*

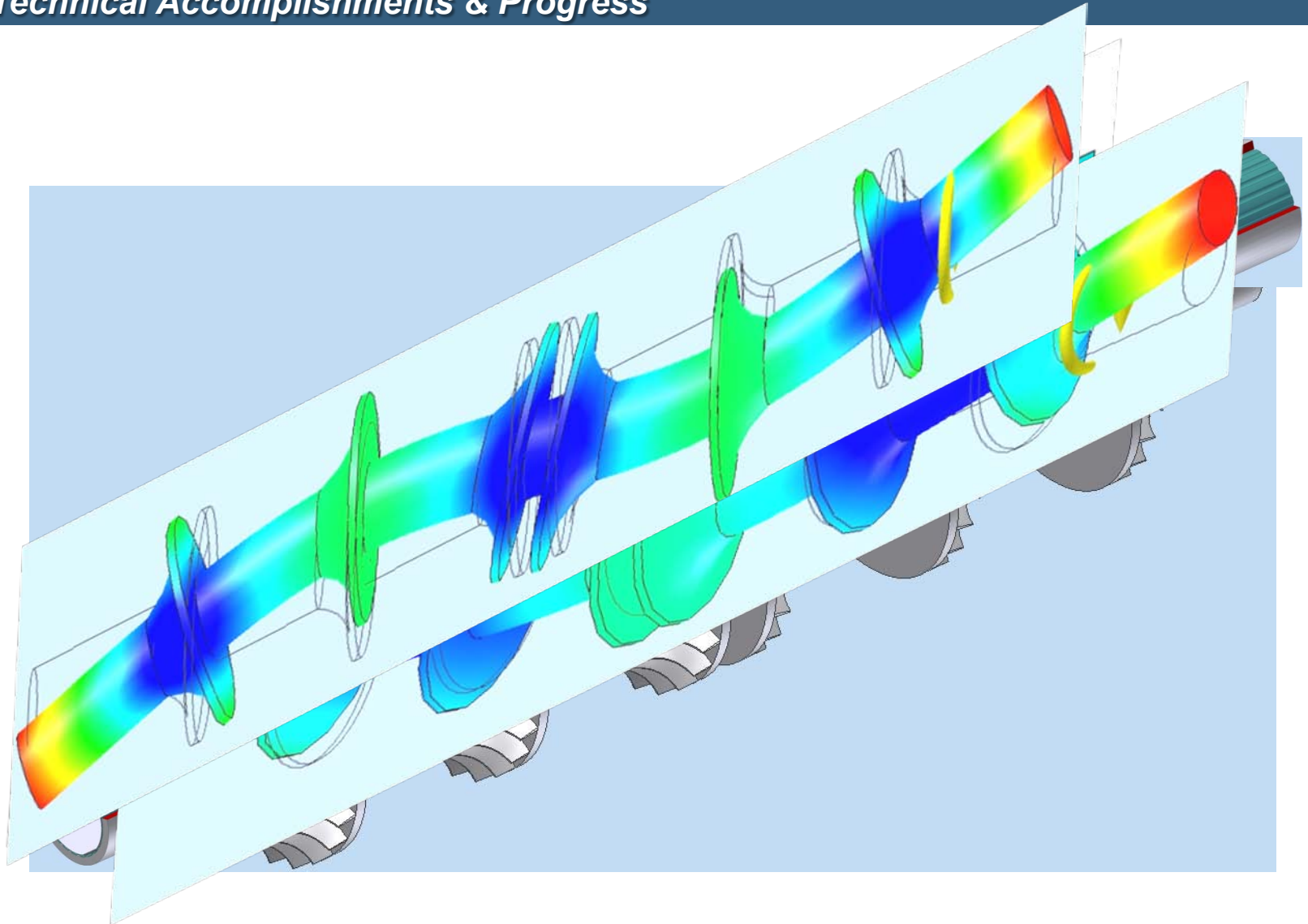

Rotordynamic Analysis

12 - Technical Accomplishments & Progress

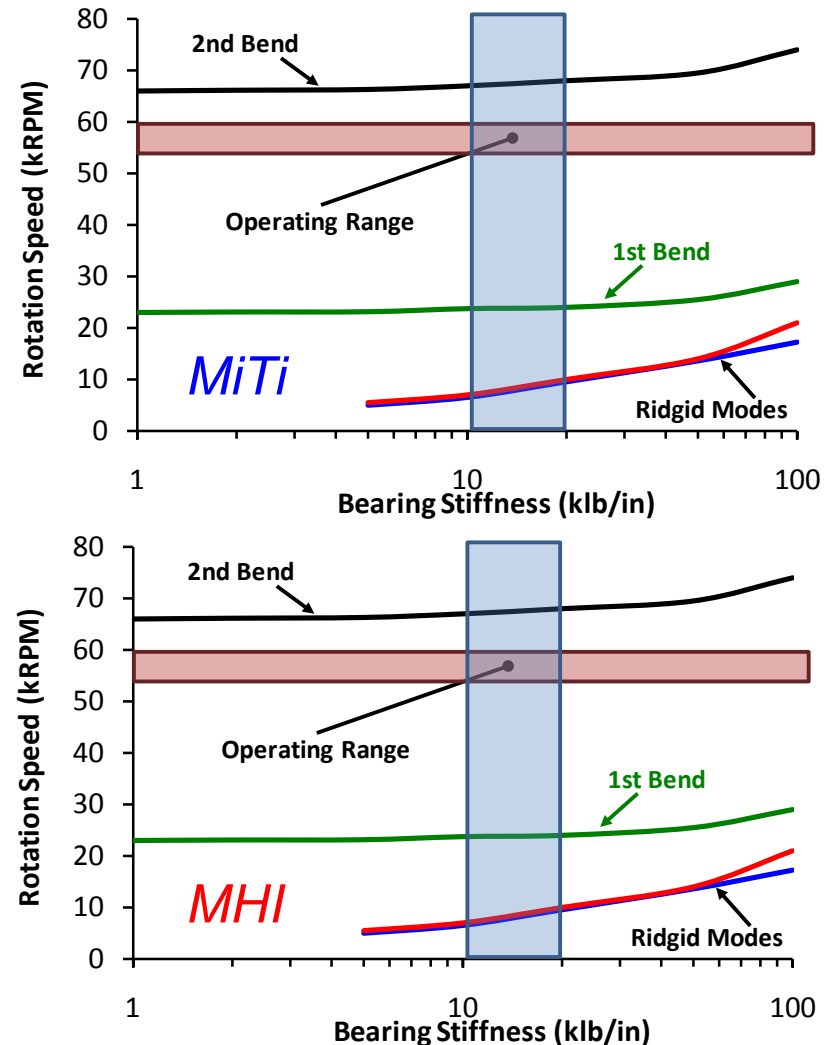

- ❑ Centrifugal Compression of H₂ is Only Feasible at Very High Speed
- ❑ The Required Operating Speed is Above the Rotor's 1st Bending Frequency
- ❑ Foil Bearings/Seal Technology (Stiffness, Damping & Load Capacity) Allows for Safe Operation Above the 1st Bend
- ❑ **The Operating Speed Range is Free of Resonant Vibration**



Multi-Frame Centrifugal Compressor Designs

13

- Technical Accomplishments & Progress

Design Strategy		
Compressor Type	Double-Entry	Single-Entry
Number of Stages	6 and 9	7 and 9
Number of Frames	2 and 3	2 and 3
Flow Capacity (Kg H₂/day)	240,000 – 500,000	
Total Pressure Ratio	2.4 - 3.33	
Total Power Input (HP)	7,800-12,000	8,300 – 12,000
Max Tip Speed (1000 ft/s)	1.6 – 1.8	1.8 - 2.0
Compressor Footprint (ft²)	145 - 160	150 - 175

Compressor Design Meets DOE Target

14

- Technical Accomplishments & Progress

Characteristics	DOE Target	MiT _i Estimates
Efficiency (%)	98%	98%
Hydrogen Capacity Target (kg/day)	200,000	240,000 – 500,000
Hydrogen Leakage	<0.5	0.2
Hydrogen Purity	99.99	99.99
Inlet Pressure (psig)	300-700	350-500
Discharge Pressure (psig)	1,000-1,200	1,226 - 1,285
Total Compressor Package (\$Million)	\$15.6	\$7.3-\$12.5*
Maintenance Cost (% total Capital Investment)	3%	<3%
Annual Maintenance Cost (\$/kW-hr)	\$0.007	<\$0.005
Package Size (sq-ft)	300-350	145 - 160
Reliability (# of Systems Required)	High - Eliminate Redundant Systems	Very High – Oil-Free Foil Bearings Eliminates Need for Redundant Systems

* Cost estimates based on data from (1) MHI for comparably sized NG compressor systems, (2) published oil and gas industry data and (3) from quotes for fabrication of major components of MiTi's compressor design.

Design of Single Stage Compressor

15

- Technical Accomplishments & Progress

Hermetically
Sealed Chamber

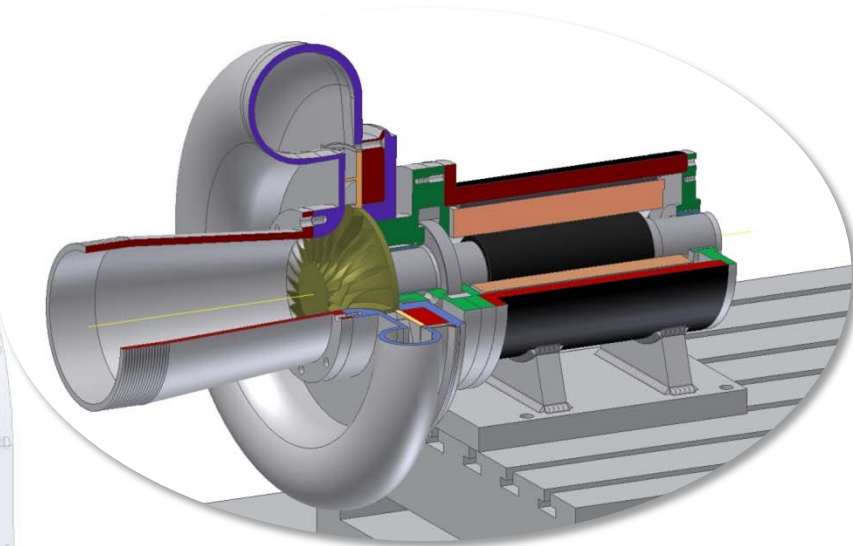
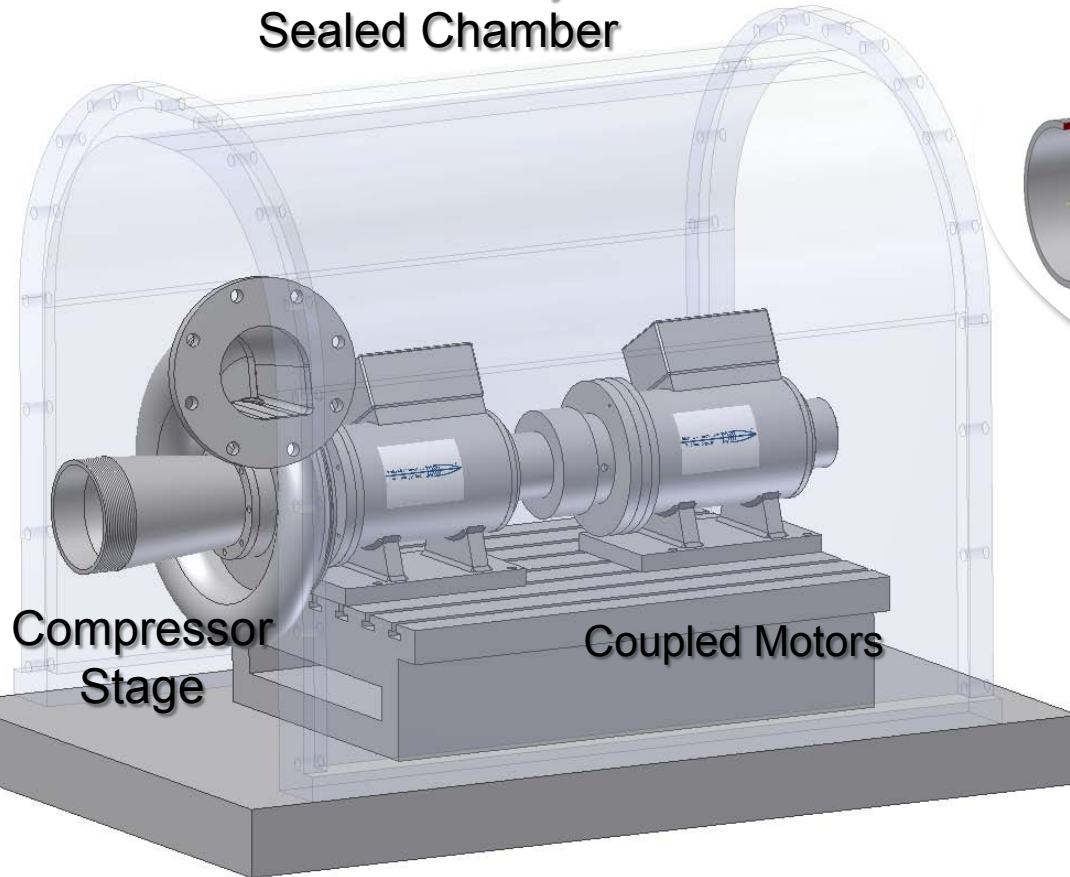

Single Stage Compressor
Test Setup with Two
Coupled, Oil-Free Motors

Closed-Loop Test Facility Design

16

- Technical Accomplishments & Progress

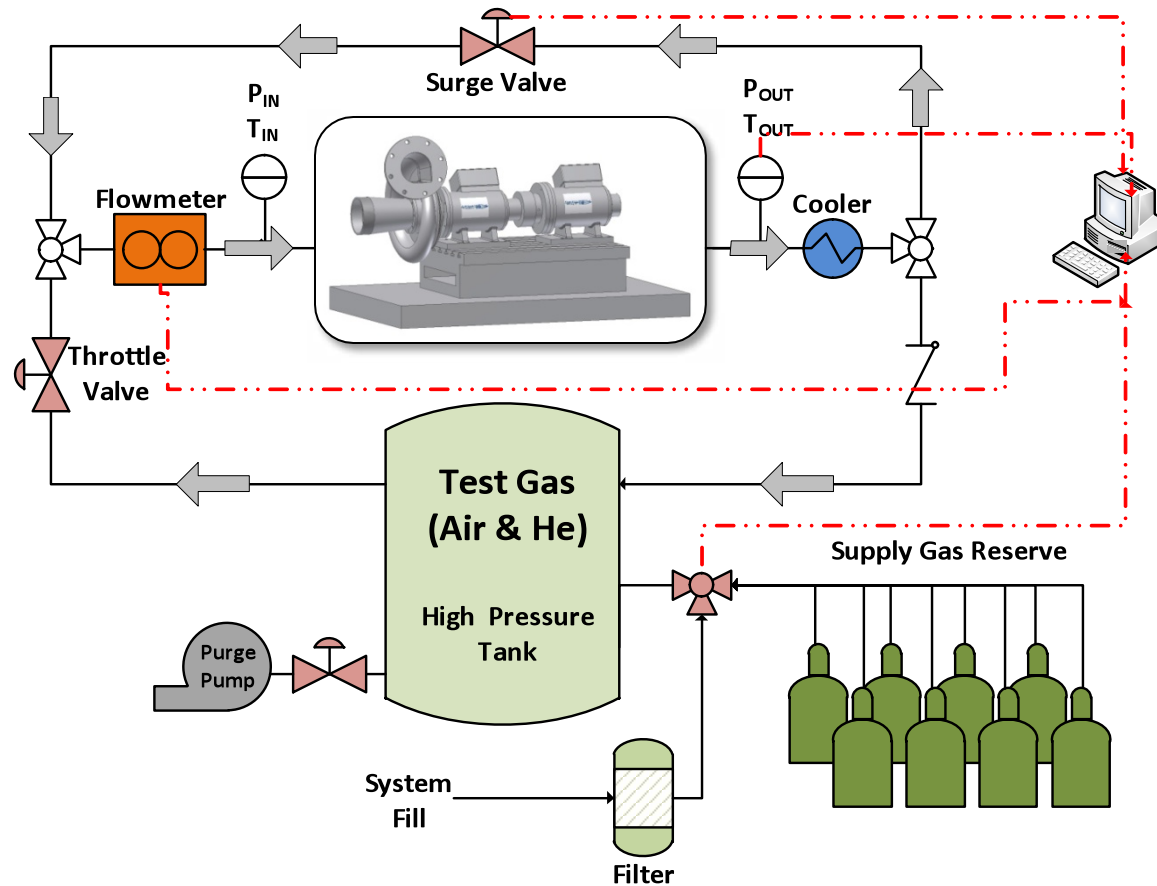

Compressor Test Facility Being Fabricated and Assembled at MiTi

Collaborations

Mitsubishi Heavy Industries

- Single-Entry Centrifugal Compressor Design
- Computational Fluid Dynamics (CFD)
- Finite Element Analysis (FEA)
- World Leader in NG Pipeline Centrifugal Compressor Systems
- Extensive Compressor Test Facilities
- In-House Turbocompressor Manufacturing

NIST Material Measurement Laboratory

- Compatibility of Foil Bearing and Foil Seal Materials in H₂ Environment



International Institute for Carbon-Neutral, Energy Research

- Consultation on Materials Selection

- ❑ Recognized Compressor Design Consultant
- ❑ CFD Consulting Group With Compressor Expertise

Proposed Future Work

18

- Proposed Future Work

- Single Stage Compressor Testing
 - All Testing to be Conducted in Accordance with Industry Standard ASME PTC-10
 - Testing to be Conducted at MiTi
 - Fabricate and Test MiTi® Single-Stage Compressor
 - Validate Compressor with Foil Bearings and Seals
 - Demonstrate Oil-Free Coupling Technology with Foil Bearings
 - Testing to be Conducted at Mitsubishi
 - Fabricate and Validate MHI Single-Stage Compressor
- Critical Comparison of the Two Designs
- Hydrogen Compatibility Evaluation of Foil Bearing and Foil Seal Materials at NIST

Summary

19

- ❑ **Relevance:** The current compression technology used for hydrogen is unreliable, resulting in the need for redundant compressors and thus higher cost. A centrifugal compressor was selected as the most reliable and efficient technology to meet the DOE 2012/2017 performance targets.
- ❑ **Approach:** Design a high-speed, multi-stage, oil-free compressor with MiTi[®] patented foil bearing/seal technology and validate performance by testing a single stage compressor.
- ❑ **Technical Accomplishments & Progress:** Design of a multi-stage single and double entry centrifugal compressor has been completed. Detailed design of a single stage is complete. Foil bearings and seals were fabricated and bench tested. The single stage compressor facility is currently under construction.
- ❑ **Collaboration:** MiTi and Mitsubishi are collaborating on the compressor design and development. NIST, Sandia and the University of Illinois are providing guidance on hydrogen compatibility of materials.
- ❑ **Proposed Future Work:** The single stage testing will be conducted to validate the compressor design. Collaboration with Mitsubishi and others continue as we progress towards the selection of a final hydrogen compressor design.

Acknowledgements

20

MiT_i is grateful for the support from the DOE Hydrogen and Fuel Cells Program and in particular, Sara Dillich, Scott Weil and Paul Bakke, for their sustained interest in our technology.

MiT_i Team

Andrew Z. Hunsberger
Said Jahanmir
Zhaohui Ren
Michael J. Tomaszewski
James F. Walton II

Mitsubishi Team

Satoshi Hata
Masayuki Kita

Other Collaborators

Rick Ricker - NIST
Petros Sofronis – U of Illinois
Brian Sumerday - Sandia

Technical Back-Up Slides

MiTi[®] Compressor Meets DOE Targets

22

Characteristics	Natural Gas Pipelines	DOE Target	MiTi Projection	
			Low Flow	High Flow
Efficiency (%)		98%	98%	98%
Hydrogen Capacity Range (kg/day)		100,000 to 1,000,000		
Hydrogen Capacity Target (kg/day)		200,000	240,000	500,000
Hydrogen Leakage		<0.5	0.2	0.2
Hydrogen Purity		99.99	99.99	99.99
Inlet Pressure (psig)	300-700	300-700	350	500
Discharge Pressure (psig)	1,000-1,200	1,000-1,200	1,285	1,226
Compressor Component Cost (\$Million)	\$9.2 ¹	\$9.0	\$4.1	\$6.1
Compressor Drive \$400/HP (\$Million)	\$6.4		\$3.2	\$6.4
Total Compressor Package (\$Million)	\$15.6		\$7.3	\$12.5
Maintenance Cost (% total Capital Investment)	9.3% ²	3%	<3%	<3%
Maintenance Cost (\$/kW-hr)	\$0.0157 ³	\$0.007	<\$0.005	<\$0.005
Package Size (sq-ft)	~1,000	300-350	145	160
Reliability (# Systems Required)		High - Eliminate Redundant Systems	Very High – Oil-Free Modular System	

¹ Oil & Gas Journal, Vol. 107.Issue_34,2010, Transportation. Special Report: Pipeline Profits Capacity Expansion Plans Grow Despite Increased Costs

² DOT/PRCI Pipeline R&D Forum December 11-12, 2003, Washington, DC;

³ Oil & Gas Pipeline Sept 14, 2009, pp77-79

Strength and Fatigue Requirements

23

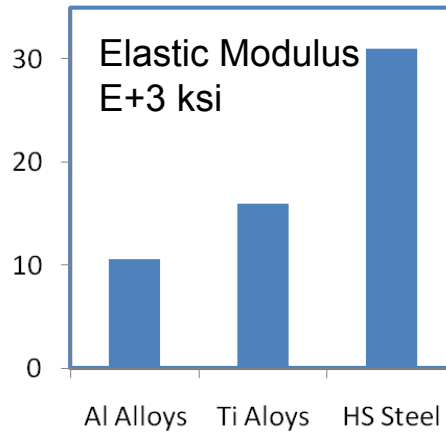
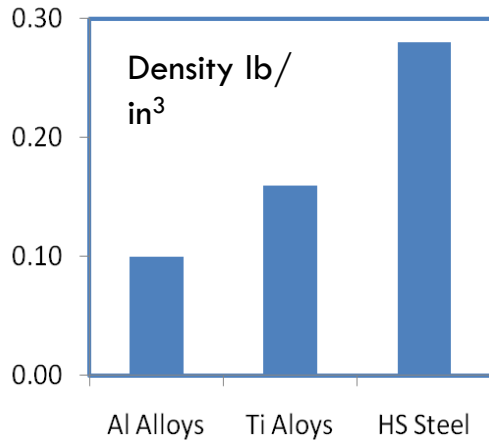

Unacceptable Fatigue
Factor of Safety for
Aluminum Alloys

Lower Potential for
Hydrogen Embrittlement for
Titanium Alloys

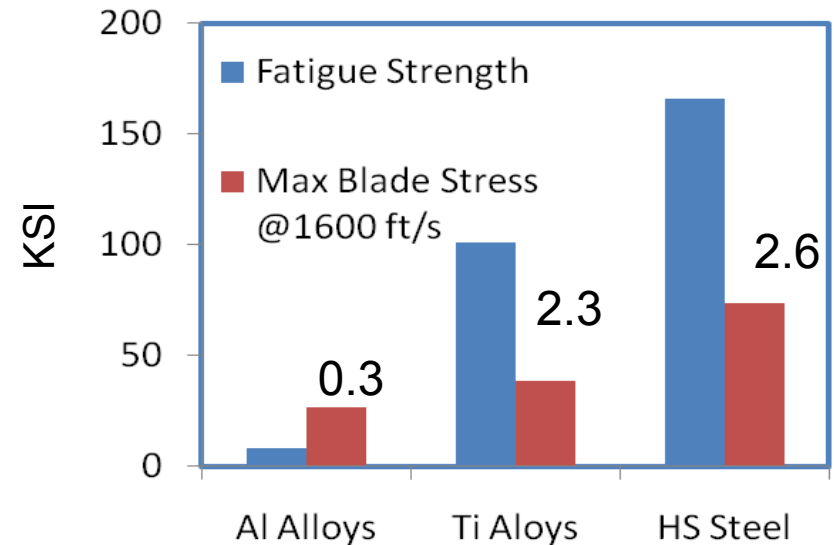
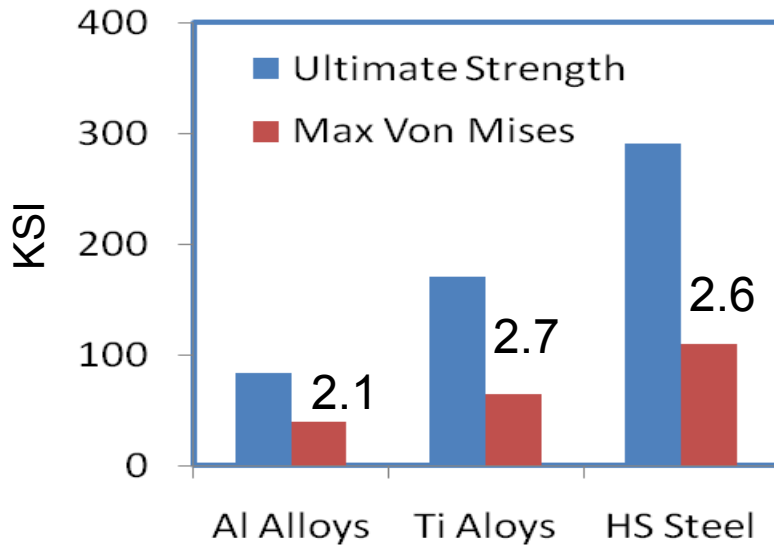

Single Stage Test – ASME PTC-10

24

- **Type 1 Test:** A test conducted with the specified gas at or very near the specified operating conditions.
- **Type 2 Test:** A Test Conducted Subject To The Permissible Deviations Listed In Table Below with Similitude Gas

Quantity	Symbol	Design Performance	PTC-10 Test Parameters
Specific Volume Ratio	v_i/v_d	1.072	1.018 – 1.126
Flow Coefficient	ϕ	0.1253	0.120 - 0.130
Machine Mach No.	Mn	0.3266	0.141 - 0.532
Machine Reynolds No.	Re _m	1.55e6	1.55e5 – 1.55e7

Test Gas Choices

25

- Hydrogen
 - Safety Issues & Facility Requirements Beyond Present Scope
- Air
 - Readily Available, But Drastic Density Variance
 - Preliminary Checkout – Below Full Speed
 - System Operation
 - Instrumentation
 - Stress/Loading
- Helium
 - Affordable Similitude Gas
 - Full Speed Aerodynamic Validation
 - Qualifies for PTC-10 Type 2 Test

Type 2 Single Stage Test: Helium

26

Quantity	Symbol	Test Rig Performance	PTC-10 Test Parameters
Specific Volume Ratio	v_i/v_d	1.052	1.018 – 1.126
Flow Coefficient	ϕ	0.1253	0.120 - 0.130
Machine Mach No.	Mn	0.3266	0.141 - 0.532
Machine Reynolds No.	Re _m	3.33e5	1.55e5 – 1.55e7

□ Type 2 Test Conditions

- Speed 39,323 rpm (70% of design)
- Inlet Pressure 100 psig
- Inlet Temperature 100°F
- Input Power 137 Hp

□ Full Speed Testing Conditions

- Speed 56,414 rpm
- Inlet Pressure 50 psig
- Inlet Temperature 100°F
- Input Power 260 Hp