



Microscale Enhancement of Heat and Mass Transfer for Hydrogen Energy Storage

Kevin Drost

Oregon State University

May 15th 2012



Hydrogen Storage Engineering
CENTER OF EXCELLENCE

ST 046

This presentation does not contain any proprietary, confidential, or otherwise restricted information



Overview

Timeline

- Feb 1st 2009 start
- June 30th, 2014 finish
- 48% Complete

Budget

- Total project funding
 - DOE - \$2,023,935
 - Contractor - \$521,685
- Funding for FY09 - \$300,00
- Funding for FY10 - \$350,000
- Funding for FY 11 - \$320,000
- Funding for FY 12 - \$400,000

Barriers

- **Barriers addressed**
 - **A)** System Weight and Volume
 - **E)** Charging and Discharging Rates
 - **H)** Balance of Plant

Partners

- **HSECoE Partners** - SNRL, PNNL, LANL, NREL, JPL, United Technologies, TRC, GM, Ford, BASF, Lincoln Composite, HSM, UQTR
- **Center Lead** - SNRL



Relevance -Objectives

- **Objective** – Use enhanced heat and mass transfer available from arrayed microchannel processing technology to ...
 - 1) Reduce the size and weight of storage system
 - 2) Improve charging and discharging rate of storage system
 - 3) Reduce size and weight and increase performance of thermal balance of plant components
- **Barriers Addressed**
 - Reduce system size and weight (Barrier A)
 - Charging and Discharging rates (Barrier E)
 - Balance of Plant (Barrier H)



Relevance – Arrayed Microchannel Processing Technology and Hydrogen Storage

- Significant reduction in size and weight when a process is limited by diffusion
 - **Reduces storage size and weight related to heat and mass transfer**
 - **Reduces size of balance of plant thermal components**
- High degree of control over process
 - **Optimizes storage for weight minimization**
- Number up rather than scale up
 - **Maintain optimum performance attained in single cell**
- Complexity can be added without increasing cost
 - **Integrate hydrogen distribution in cooling surfaces**
- Low thermal mass and high heat and mass fluxes will allow rapid start-up and response to transients
- Attractive high volume, low cost manufacturing options exist.



Approach - Programmatic

- **Phase 1: System Requirements & Novel Concepts**
 - OSU focused on simulation and experimental investigations to identify and prioritize opportunities for applying microscale heat and mass transfer enhancement techniques.
 - Working with other team members, OSU identified the highest value applications and conducted experimental investigations and modeling to collect data necessary to support the Go/No-Go decision to proceed to Phase 2.
- **Phase 2: Novel Concepts Modeling, Design, and Evaluation**
 - For each high-priority application, OSU is developing predictive models, design and evaluating components, fabricate proof-of-principle test articles, conduct proof-of-principle tests, and using the results to validate the predictive models.
 - With other team members, OSU will select one or more high-priority components for prototype demonstration.
- **Phase 3: Subsystem Prototype Construction, Testing, and Evaluation**
 - For each high-priority component, OSU will design, optimize, and fabricate the component.



Approach – Technical Approach to Phase Two Scope of Work

- For each high priority application we use microchannel technology to reduce barriers to heat and mass transfer and to facilitate integration with other storage system components (i.e. adsorption media)
- Optimize the performance of a single unit cell or module and then “Number Up” to attain desired performance
 - Develop appropriate simulation tools
 - Validated simulation tools by experimental investigations
 - Use simulation to optimize a unit cell
- Validate microlamination as a path to “numbering up” by low cost high volume manufacturing



Technical Accomplishments

- **Technical Progress Relative to 2012/2013 Milestones** - Completed feasibility studies and initiated experimental investigations on the two highest value applications:
 - Modular Adsorption Tank Insert (MATI)
 - Microchannel Combustor-Recuperator for Hydrogen Conditioning in Adsorption System
- **Technical Progress relative to Objectives:**
 - 1) Reduce the size and weight of storage and Improve charging and discharging rate of storage – **MATI**
 - Successfully Completed Feasibility Study
 - Identified Development Strategy to meet 9.2 kg and 3.4 liter weight goal with a 3 minute charge time for a 5.6 kg H₂ storage system
 - We have initiated experimental investigations and qualification of aluminum as a material of construction to support development strategy
 - 2) Reduce size and weight and increase performance of thermal balance of plant components – **Microchannel Combustor-Recuperator-for Hydrogen Conditioning**
 - Successfully completed experimental validation of Oil Heater design
 - Identified preferred application
 - Developing .5 kW_t demonstration for integration in JPL test loop

Barriers A and E - Modular Adsorption Tank Insert (MATI) Design Concept and Status

System Concept

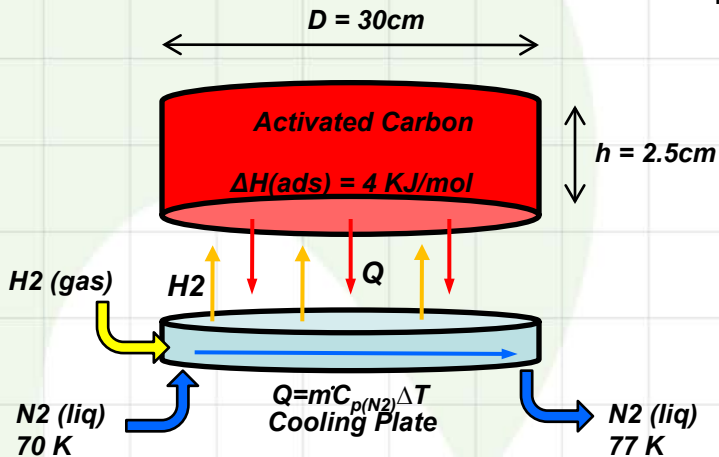

- Cross-flow HX
- Heat of adsorption removed by LN2
- Radial H_2 access to adsorption bed

Stack of plates can be enclosed to contain media

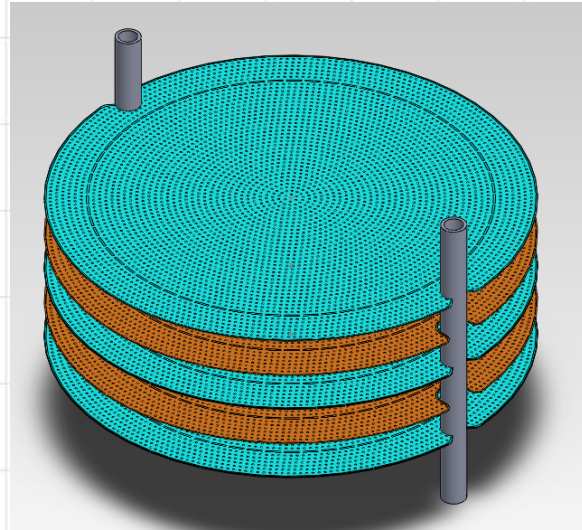

Why?

- 1) Separate cooling function from adsorption allowing a wider range of cooling strategies
- 2) Facilitates use of fuel cell waste heat for storage discharge
- 3) Optimized for use of densified packed media
 - Low void fraction (<5%)
 - Insensitive to mechanical failure of the media

System Mass by Design

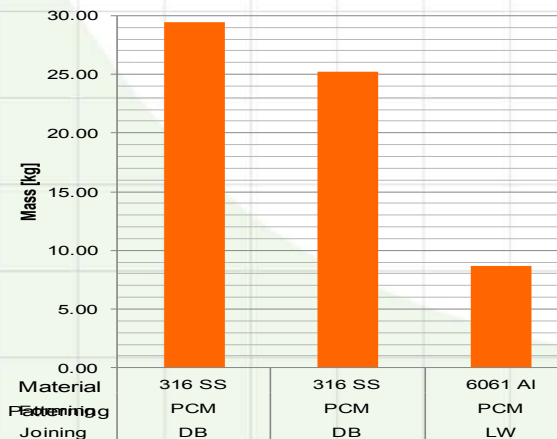

Development Plan

- Phase 1 – S.S. with combined cooling and H_2 distribution plates
- Phase 2 – S.S. with separate cooling and H_2 distribution plates
- Phase 3 – Al with separate cooling and H_2 plates and enhanced media conductivity

Status

- Completed assembly of cryogenic test apparatus
- Completed fabrication of phase 1 single and multi module test articles
- Completed design of phase 2 test articles
- Initiated qualification of aluminum as a material for microlamination
- Initiated development of densified media conduction enhancement



Barriers A and E – MATI Cost Estimate

- Process-Based Cost Modeling Results (Cost-of-Goods-Sold (COGS))
- Exploring cost reduction opportunities with Ford Motor Company

MATI COGS

Production Volume = 500,000 Devices/Yr

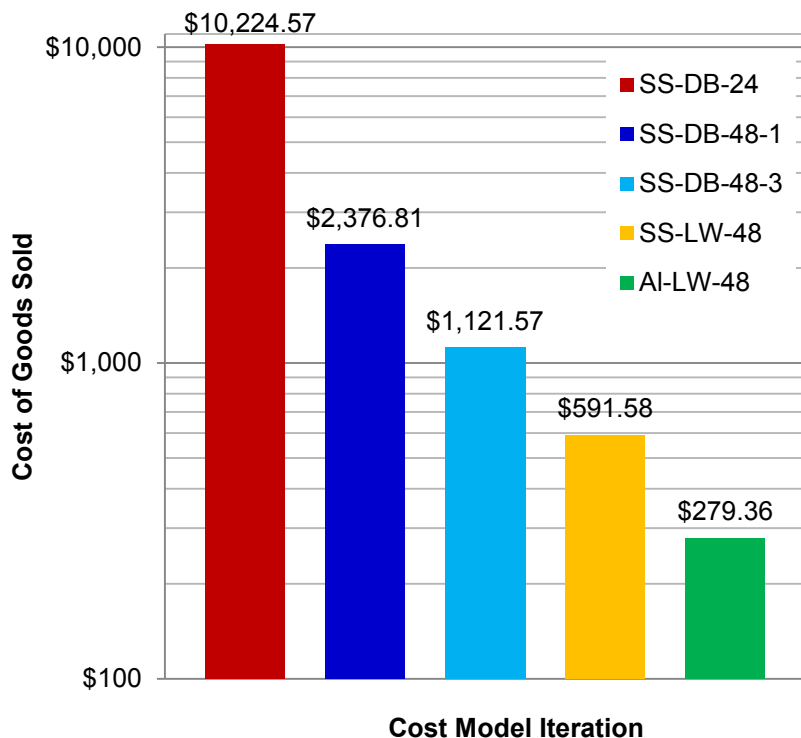

MATI COGS

AI-LW-48

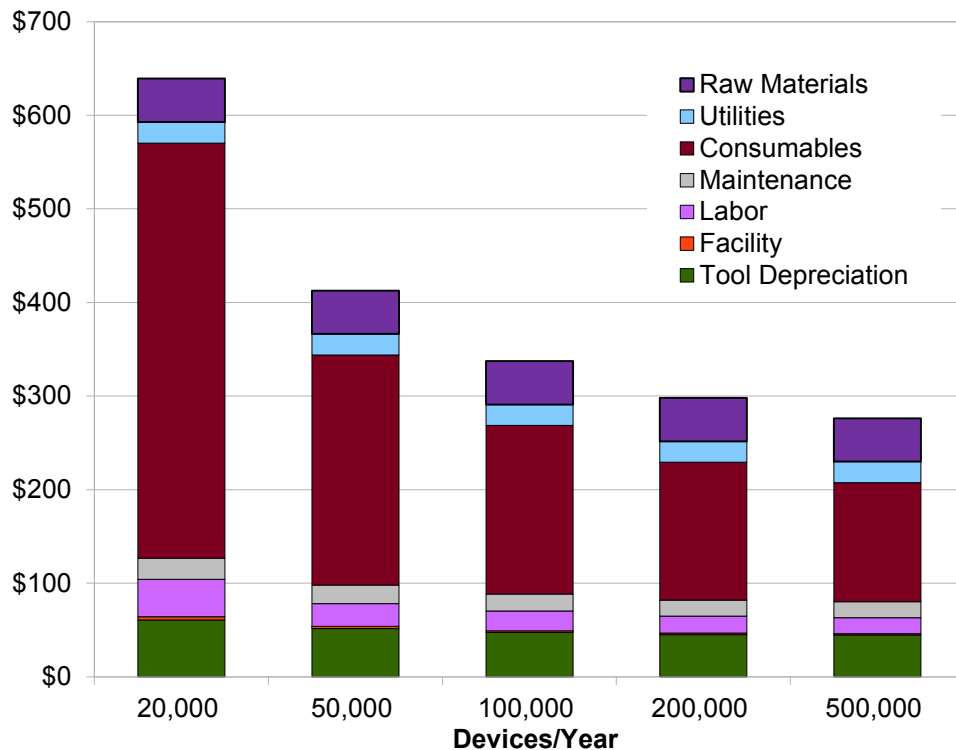



Barriers A and E - Impact of bed conduction on MATI plate spacing with separate hydrogen distribution plate

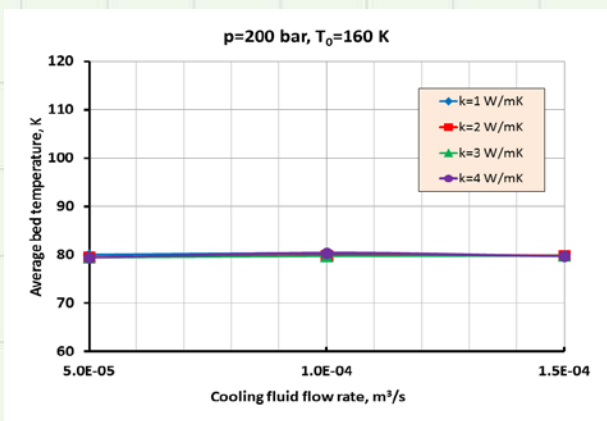

2 cm spacing
180 sec fill time

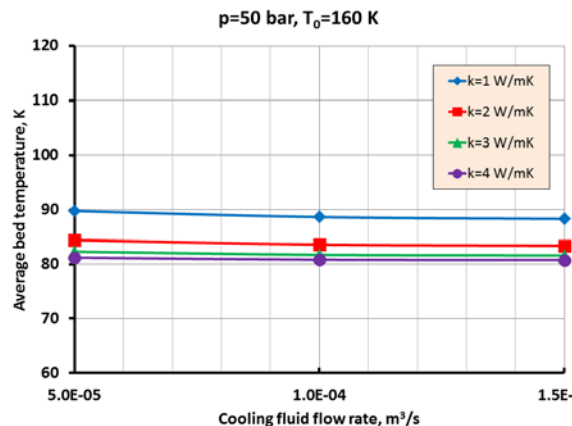

4 cm spacing
180 sec fill time

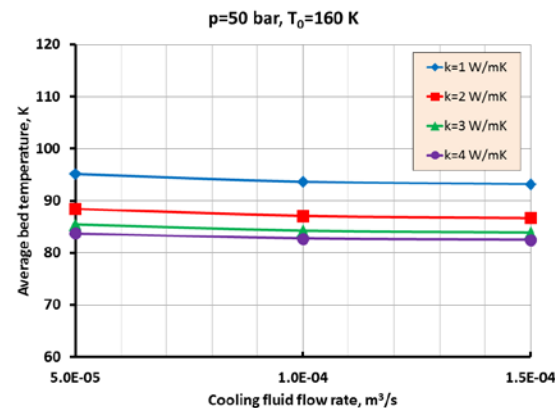

5 cm spacing
180 sec fill time

Conclusions

- We can attain a 2 cm spacing without any conduction enhancement
- To attain a 5 cm spacing the effective conductivity of the “hockey puck” needs to be between 2 and 3 W/mK



Barriers A and E - How do will we get a MATI “hockey puck” conductivity of 2 to 3 W/mK?

- Micro engineer the hockey puck
 - Use aluminum to enhance conductivity
 - Embed thin aluminum fins in the hockey puck
 - Use the enhanced conductivity from aluminum fins to reduce or eliminate the need to add 5 to 10% by weight of Expanded Natural Graphite (ENG) which is the current approach to conductivity enhancement
- A Simulation study is underway to select optimum fin characteristics and ENG loading
 - 24 fins (125 microns wide, 1 cm height with 1.25 cm fin spacing) and 10% ENG will yield a bed conductivity of 3 W/mK for MOF-5 with a density of .3 g/cm³
- Unresolved Issues
 - Impact of material densification on fins
 - Impact of fins on durability of hockey puck
- Work with Ford (HSECoE supplier of MOF-5) to demonstrate a micro engineered hockey puck

Barriers A and E – MATI Separate Effects Heat Transfer Testing

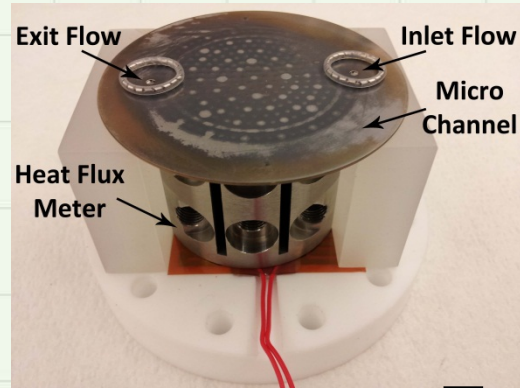

Partially assembled view of the test section

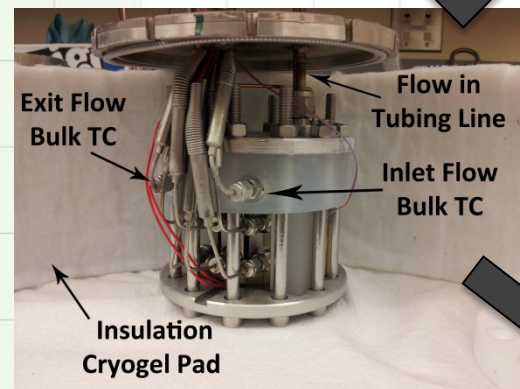

Assembled view of the test section

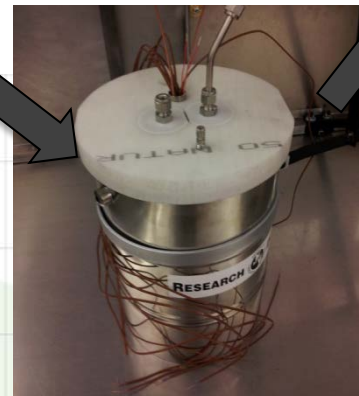

Test section dewar

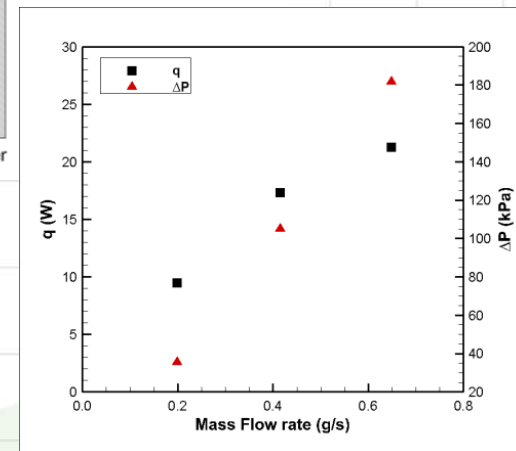
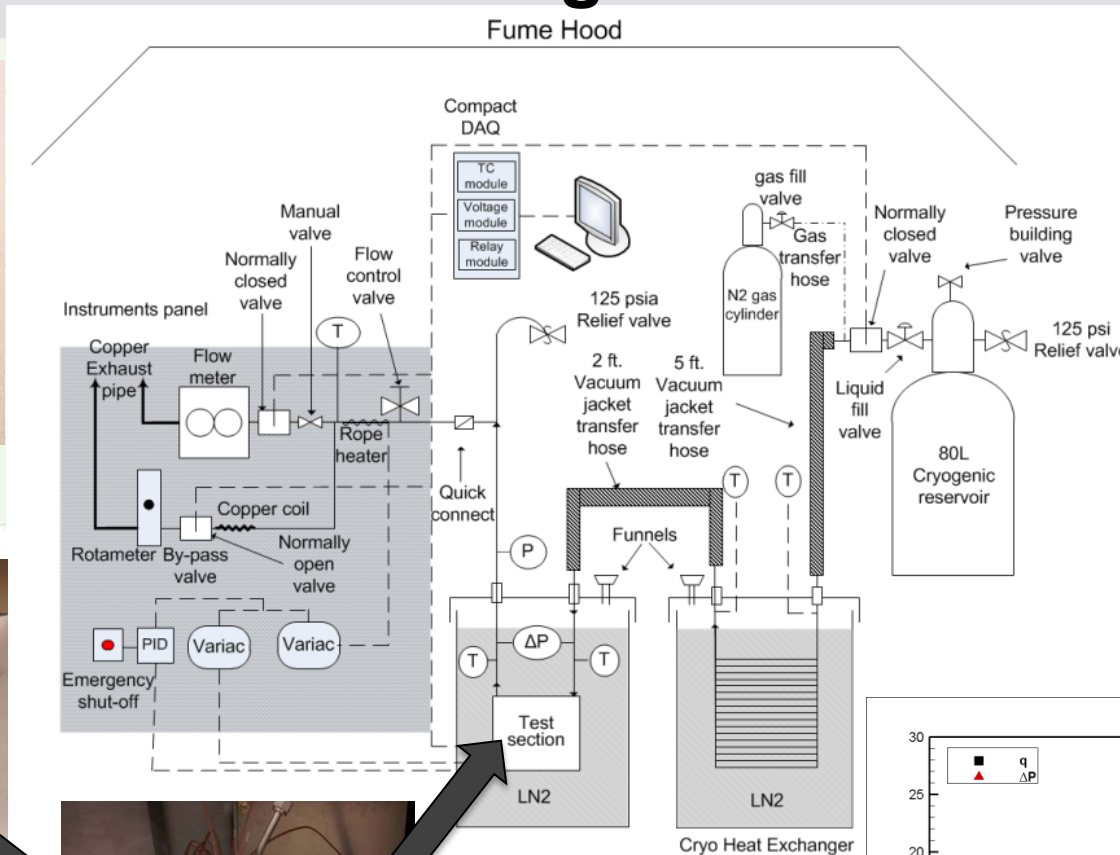

Preliminary heat transfer test with N₂ gas

Barriers A and E – MATI Integrated Adsorbent Test Bed

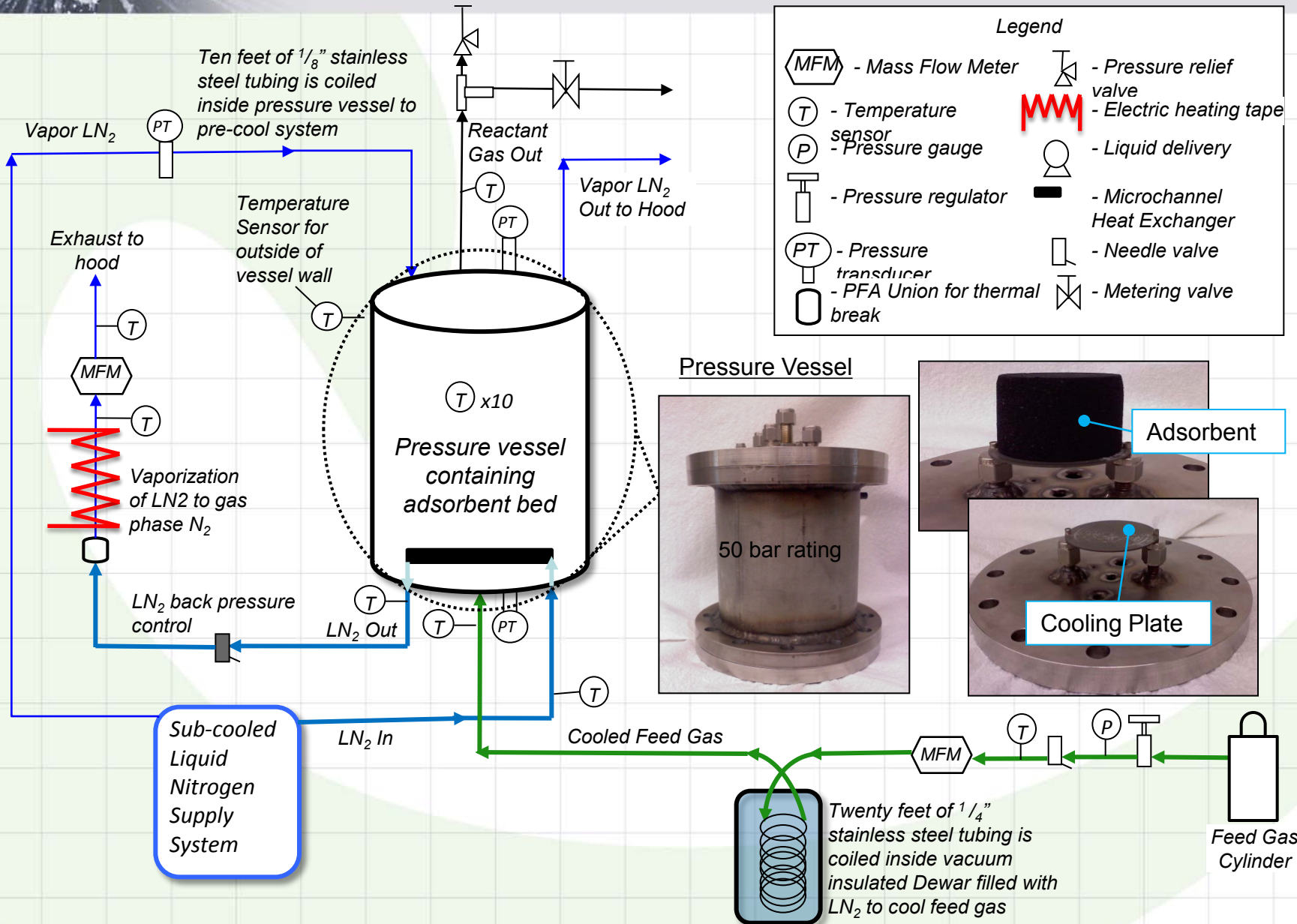

Legend

- (MFM) - Mass Flow Meter
- (T) - Temperature sensor
- (P) - Pressure gauge
- [Regulator Symbol] - Pressure regulator
- (PT) - Pressure transducer
- [PFA Union Symbol] - PFA Union for thermal break
- [Valve Symbol] - Pressure relief valve
- [Heating Tape Symbol] - Electric heating tape
- [Liquid Delivery Symbol] - Liquid delivery
- [Heat Exchanger Symbol] - Microchannel Heat Exchanger
- [Needle Valve Symbol] - Needle valve
- [Metering Valve Symbol] - Metering valve

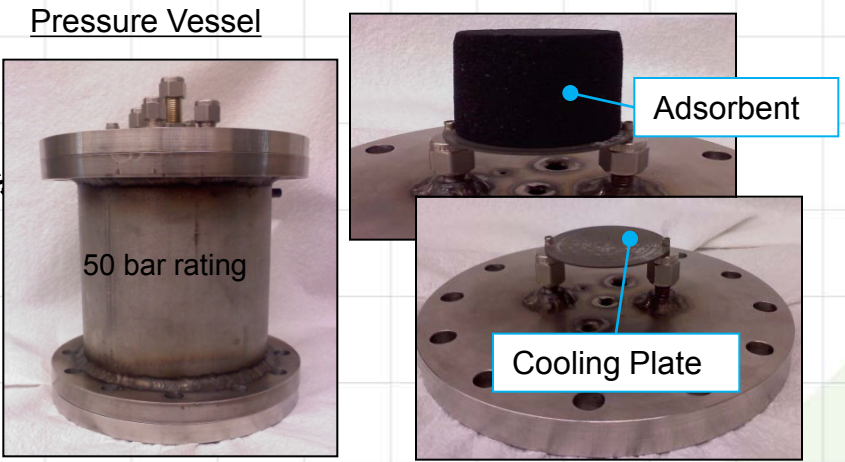



Barriers A and E – MATI Integrated Adsorption Bed Testing – Preliminary Data

Room Temperature Filling Experiments

- *Minimal temperature rise inside vessel during compression (vessel entrance).*
- *Developed temperature profile within activated carbon bed.*
- *Approximately 120 second active filling time.*

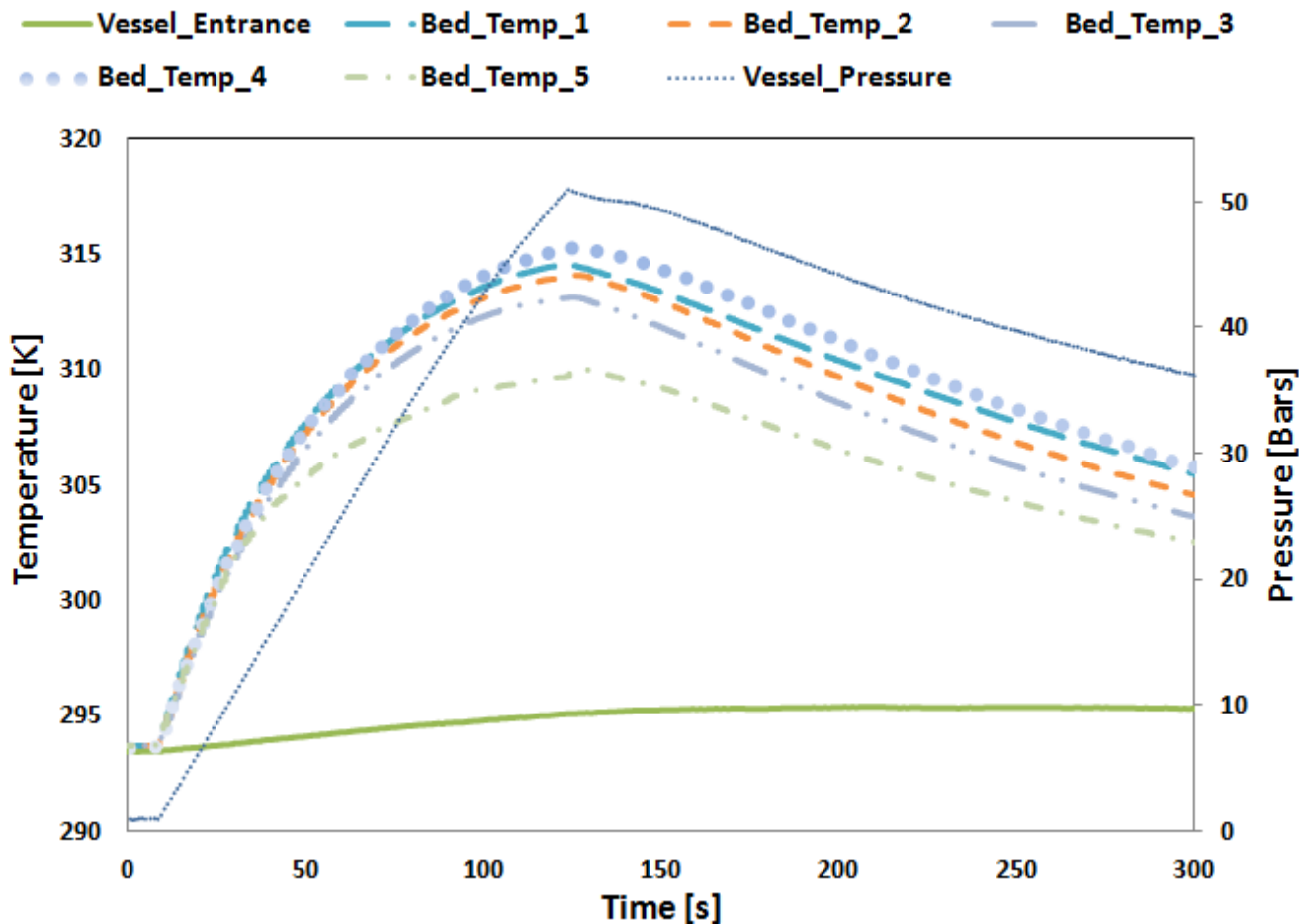



Barriers A and E – Aluminum Laser Welding Studies

- Laser welding SS 316 (500 μm thickness)

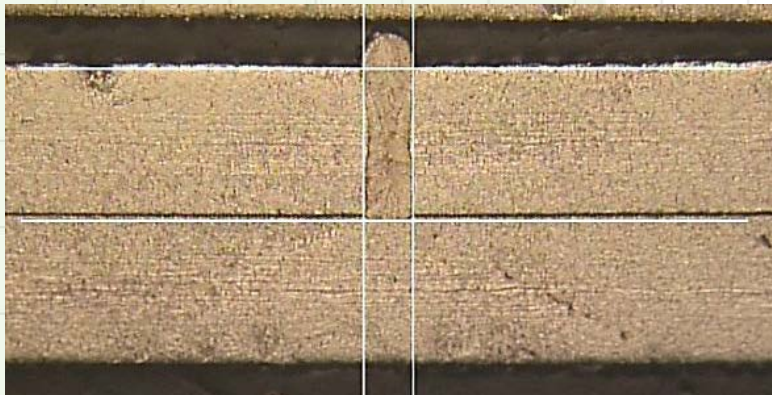

- Laser welding Al 6061 (500 μm thickness)

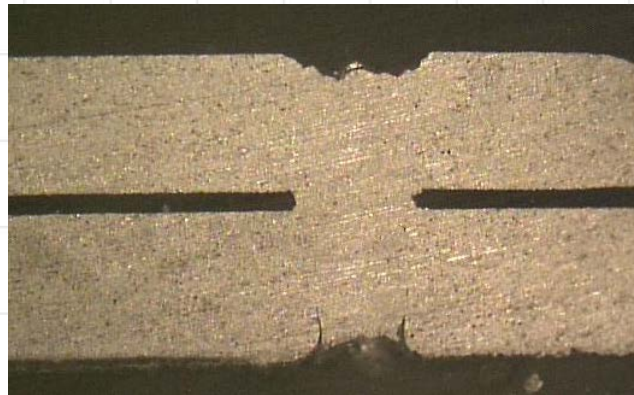

Weld depth vs Weld speed
Power = 1000 W

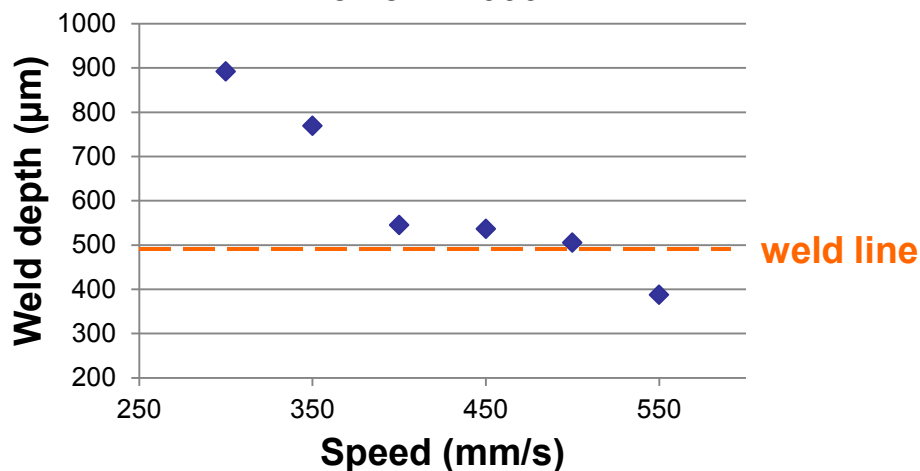

- Experimental Plan
 - Identify and eliminate defect modes (e.g. gap between laminae above)
 - Quantitatively evaluate welds using lap shear testing
- To date, have overcome major issues with Al welding
 - Oxidation leading to gas porosity
 - using argon shield gas
 - Solidification cracking
 - using optimum levels of power and speed to reduce cracking



Barriers A and E – MATI Multi-module Separate Effects Test Article Design

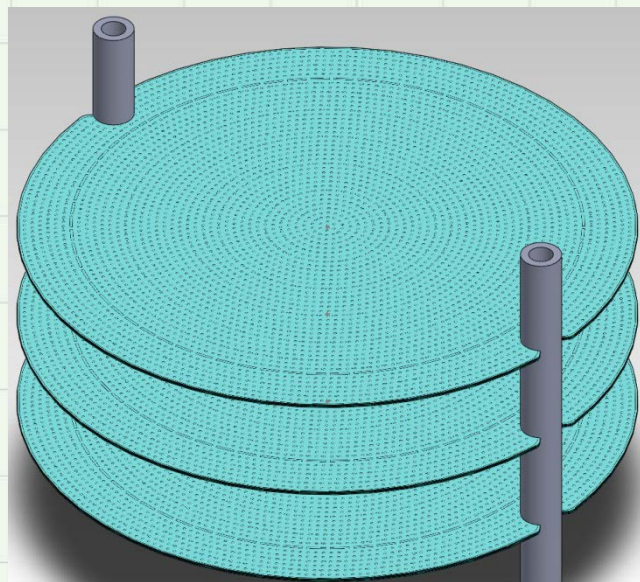

30 cm MATI Concept

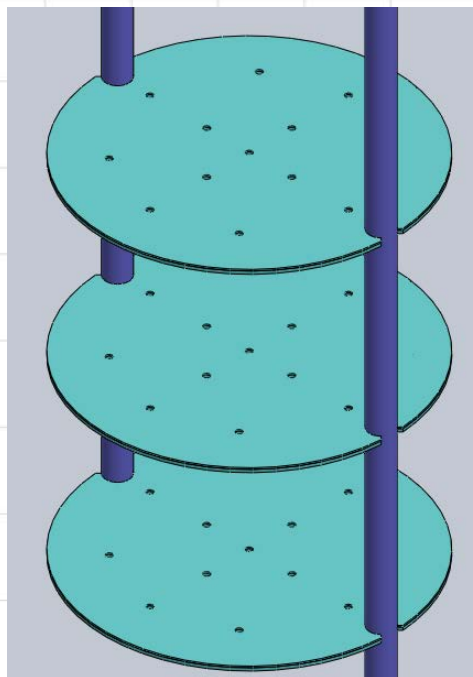

5 cm MATI Test Article
Concept

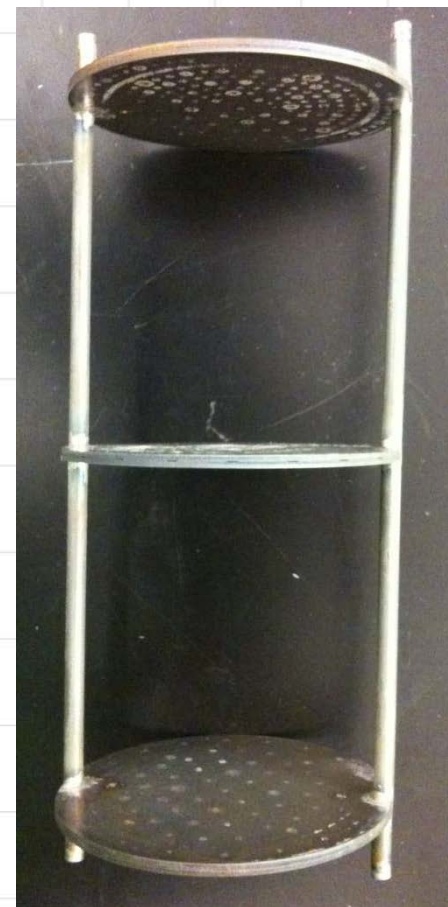

5 cm MATI Test Article
Prototype



Barriers A and E – MATI Smart Goals and Conclusions

Smart Goals:

- Report on ability to develop and demonstrate a Modular Adsorption Tank Insert designed for a system storing 5.6 kg of H₂ and consisting of 60% densified media and capable of allowing less than 3 min. refueling time and H₂ release rate of 1.6 g/s H₂/sec with a mass less than 5.7 kg and a volume less than 2.5 liters.
- Report on ability to develop and demonstrate a Modular Adsorption Tank Insert designed for a system storing 5.6 kg of H₂ and consisting of 100% densified media and capable of allowing less than 3 min. refueling time and H₂ release rate of 1.6 g H₂/sec with a mass less than 9.4 kg and a volume less than 4.2 liters.

Conclusions

- If successful, our research plan will demonstrate a tank insert capable of meeting our project smart goals
- All of our test apparatus are either assembled or in shake down testing
- Initial testing will be on powered activated carbon and we will proceed to testing “hockey pucks”.



Barrier H - Microchannel Combustor-Recuperator-Oil-HX Concept

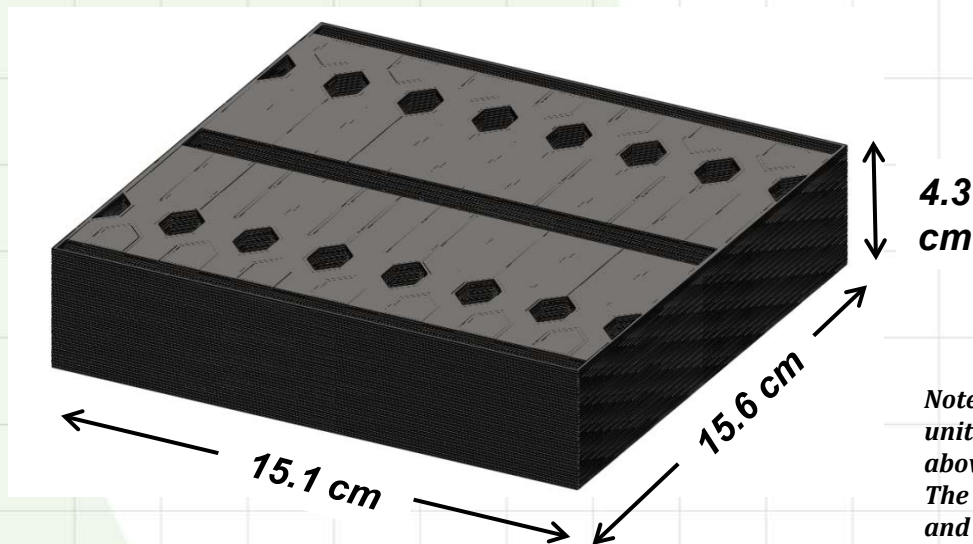

	12 kW OSU	30 kW OSU	30 kW Sandia
Width (cm)	15.1	22.2	32.0
Length (cm)	15.6	21.1	38.1
Height (cm)	4.3	7.9	29.7
Volume (L)	1.0	3.7	36.2
316 SS Weight (kg)	3.8	11.7	Unknown
3003-O Al Weight ² (kg)	1.3	4.0	Unknown

4.3 cm

15.1 cm

15.6 cm

12 kW Microchannel Combustor-Recuperator-Oil-HX
With an estimated cost of \$120 to \$200 at a production rate of 500,000 units per year

Notes: 1. Estimates are based on detailed numerical simulations of a unit cell. The estimates include components shown in the schematic above. Not included inlet and exit ducting, insulation, pump and blower. The Sandia design¹ included the inlet and exit ducting. However, the size and weight estimates should not change dramatically with inclusion of inlet and exit ducting.

2. The Aluminum combustor size is a potential estimate and represents a low-risk extension of the SS combustor. Further work is needed in testing and fabrication side to ensure its performance and manufacturability.

1) T.A. Johnson, M.P. Kanouff, "Performance Characterization of a Hydrogen Catalytic Heater," SAND2010-2474, Sandia National Laboratories, Livermore, CA, 2010.

Barrier H - Microchannel Combustor-Recuperator-Oil-HX Test Article

Exploded View of Combustor test article

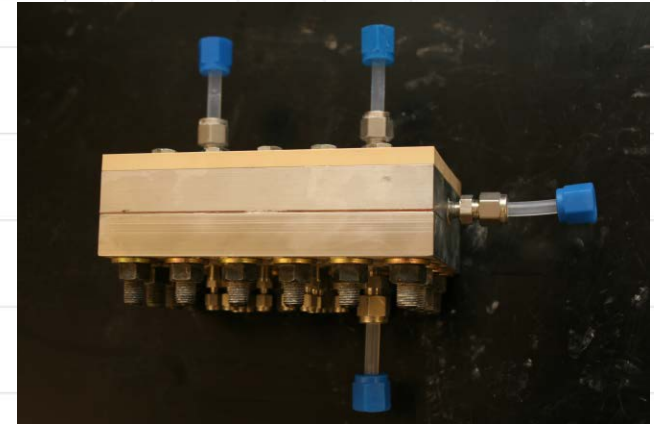
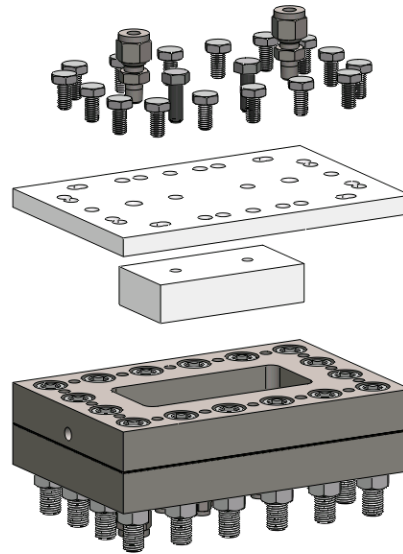
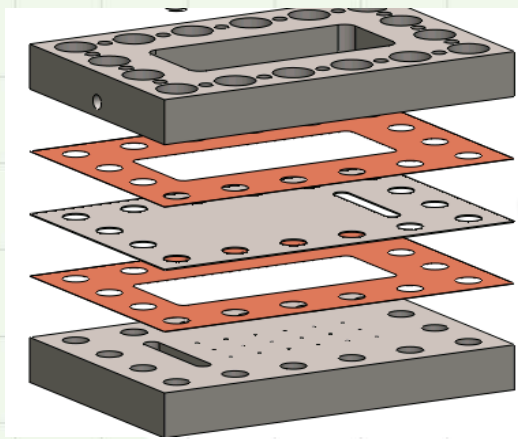

Assembled Test Section

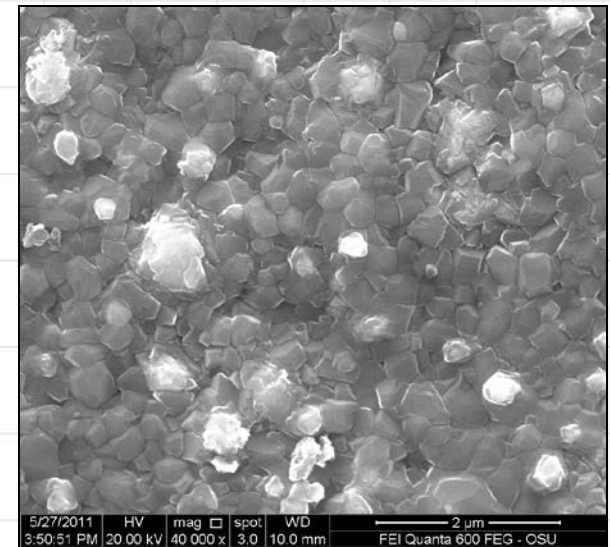

SEM of Wet Deposited Catalyst

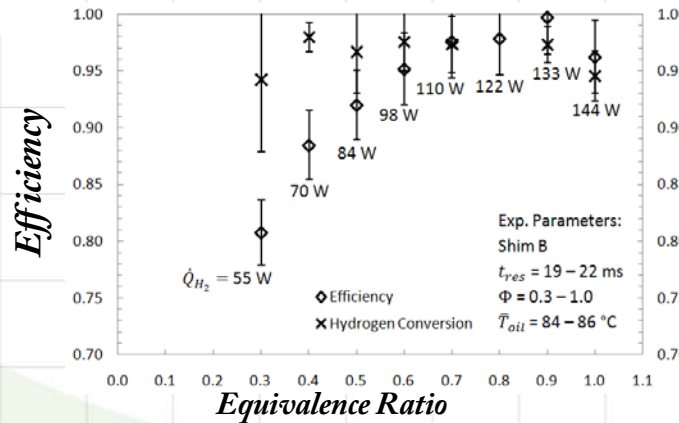

Sample Data

Key Finding –
 Experimental results validated simulation model and size and weight estimates. See Haley, D. B., and Narayanan, V., 2011

Barrier H - Microchannel Combustor-Recuperator-Hydrogen-HX Adsorption System Options

Option 1.	<i>PRV pre-conditioning (HX)</i>
Option 2.	<i>H₂ conditioning for fuel cell (CHX)</i>
Option 3.	<i>H₂ conditioning for "cold-start" (CHX)</i>
Option 4.	<i>In-tank heating system (CHX)</i>

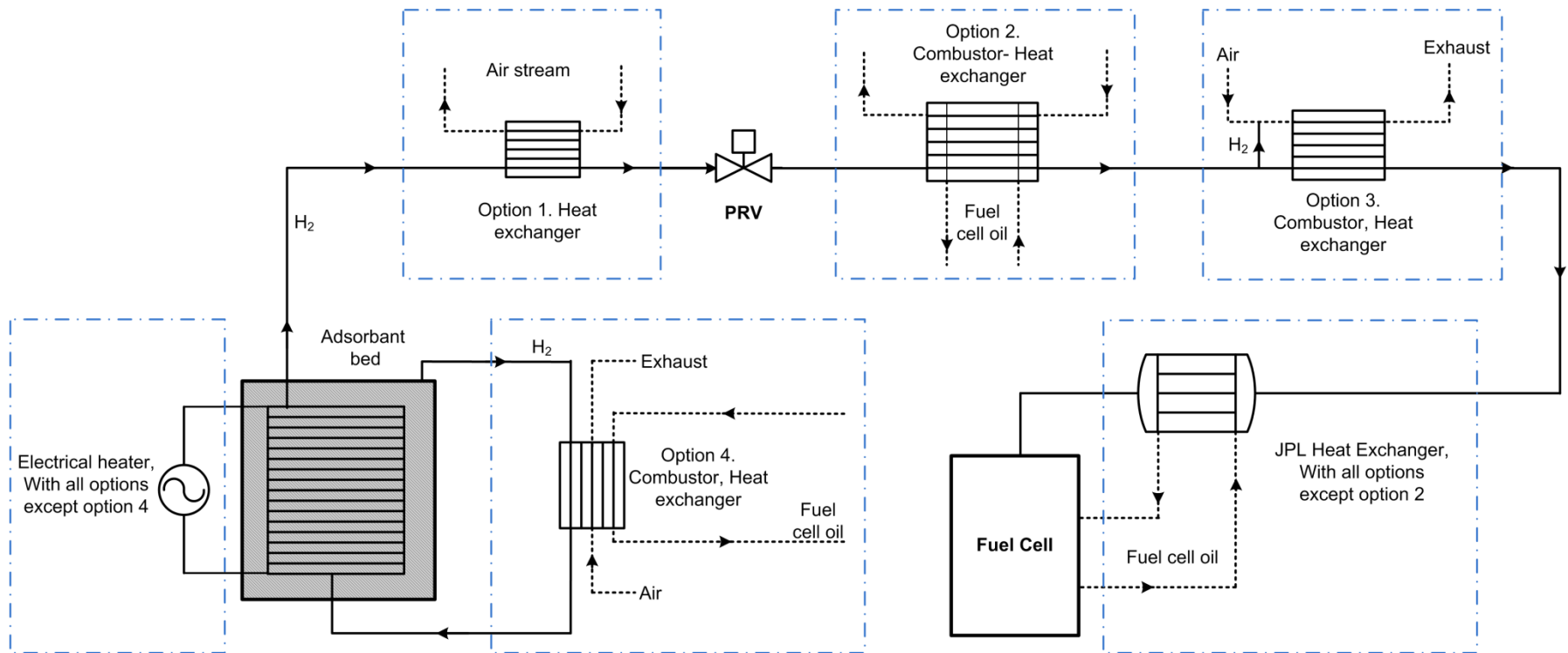



Barrier H - Microchannel Combustor-Recuperator-Hydrogen-HX Unit Cell Design

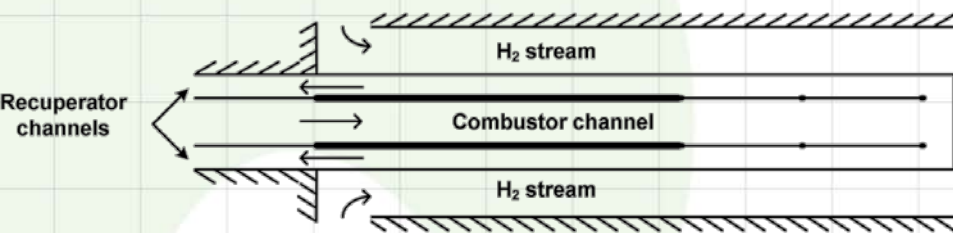

The unit cell design integrates the combustor and heat exchange unit operations. The recuperator channel isolates the combustor from the cold hydrogen stream and provides high catalytic conversion. The combustor and H₂ stream channel heights are 300 μm each and recuperator channel height is 150 μm. Channel width and length are 1 mm and 15 mm, respectively.

Including four headers and insulation (Pyrogel XT), the total volume was estimated to be 9 cm × 8 cm × 9.1 cm. Total weight of the device with insulation was estimated at 0.88 kg with the total volume of 0.65 liters.

Design Considerations

Location	Secondary system attached to or downstream from a traditional heat exchanger
Purpose	Heat the H ₂ stream to the acceptable fuel cell temperature range when ambient temperature is below -30 °C and/or the fuel cell coolant is at ambient temperature
Pressure range	Inlet pressure of 5 to 20 bar; outlet pressure greater than or equal to 5 bar
Temperature range	Inlet temperature of ~200 K
Target Heating	Increase temperature to a minimum of -40 °C
Fluid flow rate	Maximum 2 g/s



Proposed FY 2012 Future Work

- Reduce Size and Weight of Storage System and Improve Charge and Discharge Rates – **Modular Adsorption Tank Insert Development**
 - Complete experimental validation of tank insert simulations and unit cell performance
 - Demonstrate ability to enhance conductivity of the “hockey puck”.
 - Optimize tank insert design to minimize weight, volume and cost
 - Complete design of Phase 3 technology demonstration
- Reduce size and weight and increase performance of thermal balance of plant components - **Microchannel Combustor-Recuperator-Oil Heat Exchanger**
 - Demonstrate unit cell for hydrogen conditioning application
 - Complete demonstration of a .5 kW_t combustor
 - Supply combustor to JPL for integration in hydrogen conditioning demonstration.



Collaboration

- Oregon State University is a member (a prime contractor) of the Hydrogen Storage Engineering Center of Excellence (HSECoE) with five federal laboratories, one university and four companies
- Development of the Modular Adsorption Tank Insert is a collaboration with Savannah River National Laboratory (SNRL), Ford Motor Company and Universite' du Quebec a Trois-Rivieres.
- Development of enhanced “Hockey Puck” conductivity. Is a collaboration with Ford Motor Company
- Development of the Microchannel Combustor-Recuperator-Hydrogen-HX is a collaboration with JPL and Savannah River National Laboratory



Project Summary

- **Relevance:** Microchannel technology can reduce size, weight and charging time of hydrogen storage.
- **Approach:** For MATI and Microchannel Combustor-Recuperator-Oil-HX
 - Use MECS techniques to enhance the performance of heat and mass transfer devices.
 - Optimize a single unit cell
 - Use microlamination to “Number Up” .
- **Technical Accomplishments:**
 - Initiated testing at cryogenic conditions for both separate effects (heat transfer coefficient and pressure drop) and integrated testing.
 - Developed a technology development plan for the MATI that will achieve performance, size and weight goals.
 - Initiated demonstration of enhance conductivity in “Hockey Puck”
 - Initiated testing to qualify aluminum as a material of construction
 - Completed component design and initiated testing of Microchannel Combustor-Recuperator-Oil-HX unit cell. Results suggest a large reduction in size and weight with a reasonable production cost. This technology is now being applied to hydrogen conditioning in the adsorption system.
- **Collaboration:** Member of HSECoE team.
- **Proposed Future Research:**
 - MATI - Complete 1) experimental validation of models, 2) demonstration of hockey puck conduction enhancement 3) qualification of aluminum as a material of fabrication and 4) optimized design.
 - Microchannel Combustor – Complete demonstration of a .5kW_t combustor for hydrogen conditioning



Supplemental Slides

HSECoE Center Organization

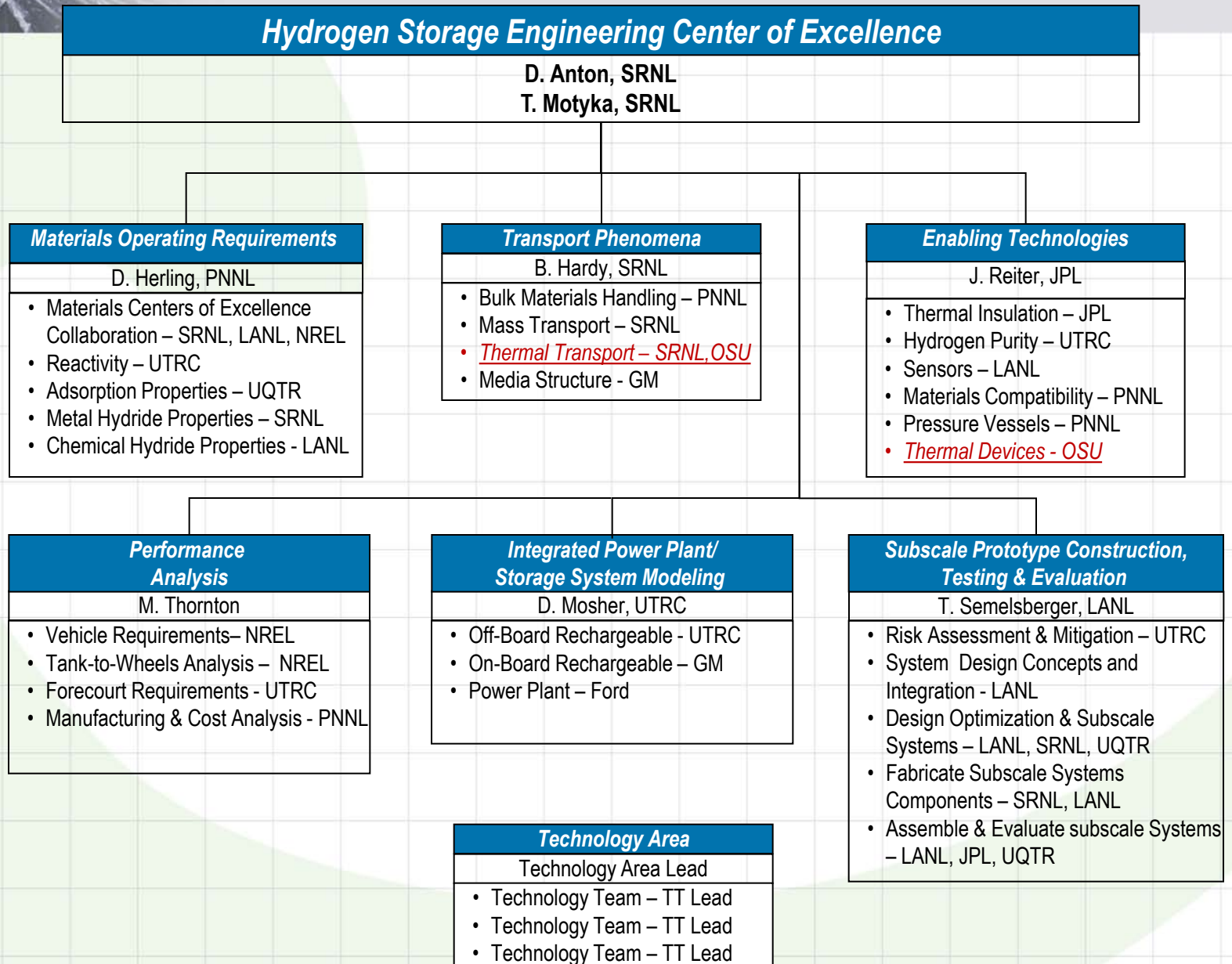



MATI System Improvement

Equivalent Geometries for 2 Adsorbent Modules

Start of Ph2

6 Months

18 Months

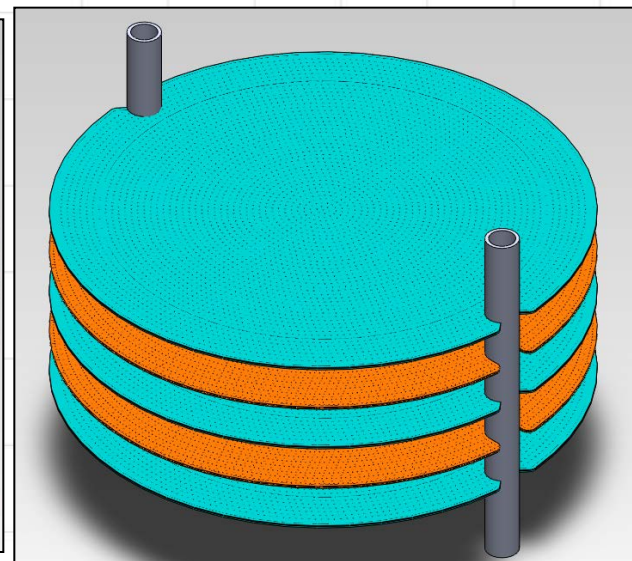
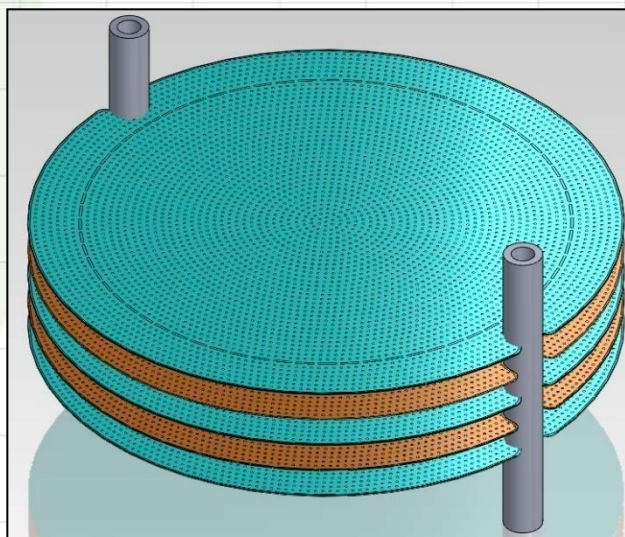
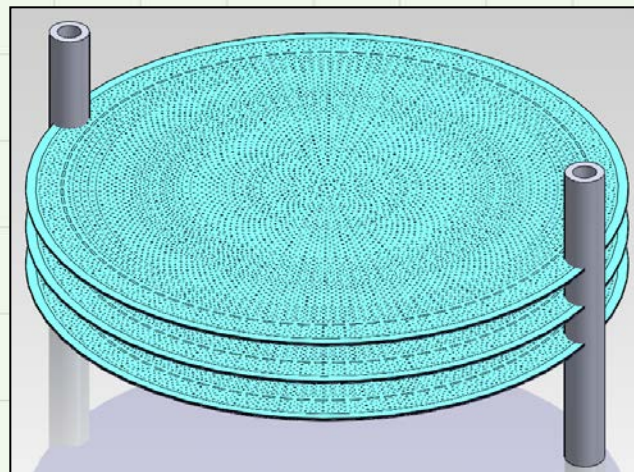

Material: **316 SS**

Module Height: **2 cm**

Key Features:

- **Fully Densified Media**
- **Integrated H₂ and LN₂ Plate**

Shim Processing:

- **Photochemical Machining**
- **Diffusion Bonding**

Material: **316 SS**

Module Height: **3.6 cm**

Key Features:

- **Fully Densified Media**
- **Separated H₂ and LN₂ Plates**

Shim Processing:

- **Photochemical Machining**
- **Diffusion Bonding**

Material: **6061 Al**

Module Height: **5.9 cm**

Key Features:

- **Fully Densified Media**
- **Separated H₂ and LN₂ Plates**
- **Enhanced Bed Conductivity**

Shim Processing:

- **Photochemical Machining**
- **Laser Welding**



MATI System Improvement vs SMART Goals for Fully Densified Media

MATI Displacement Volume

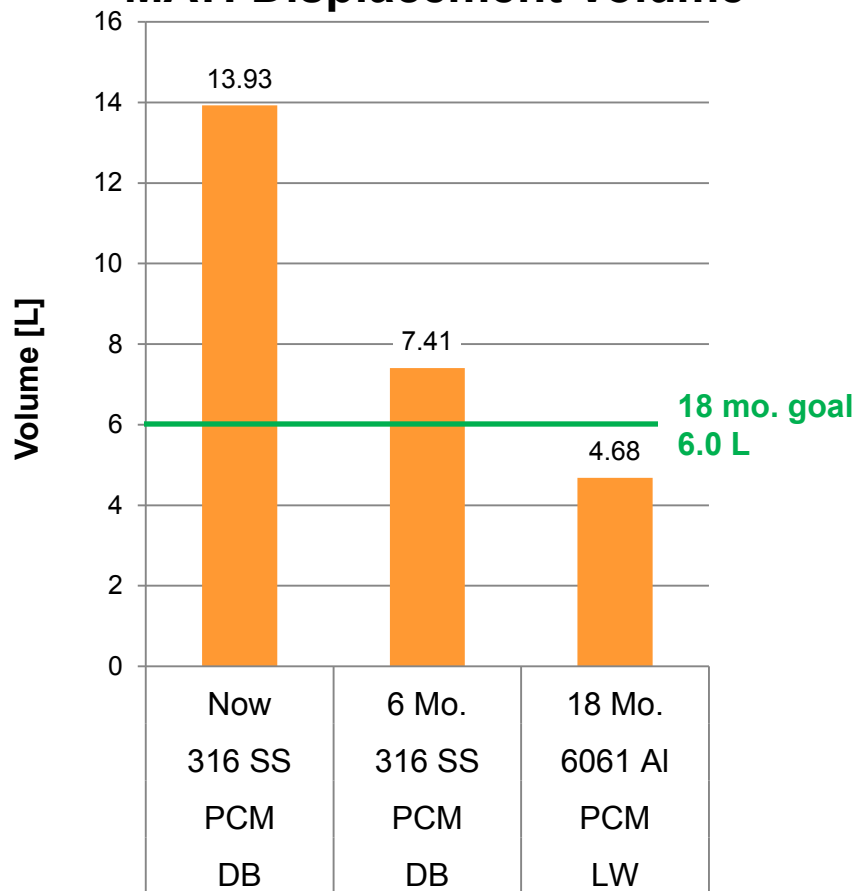

MATI Mass

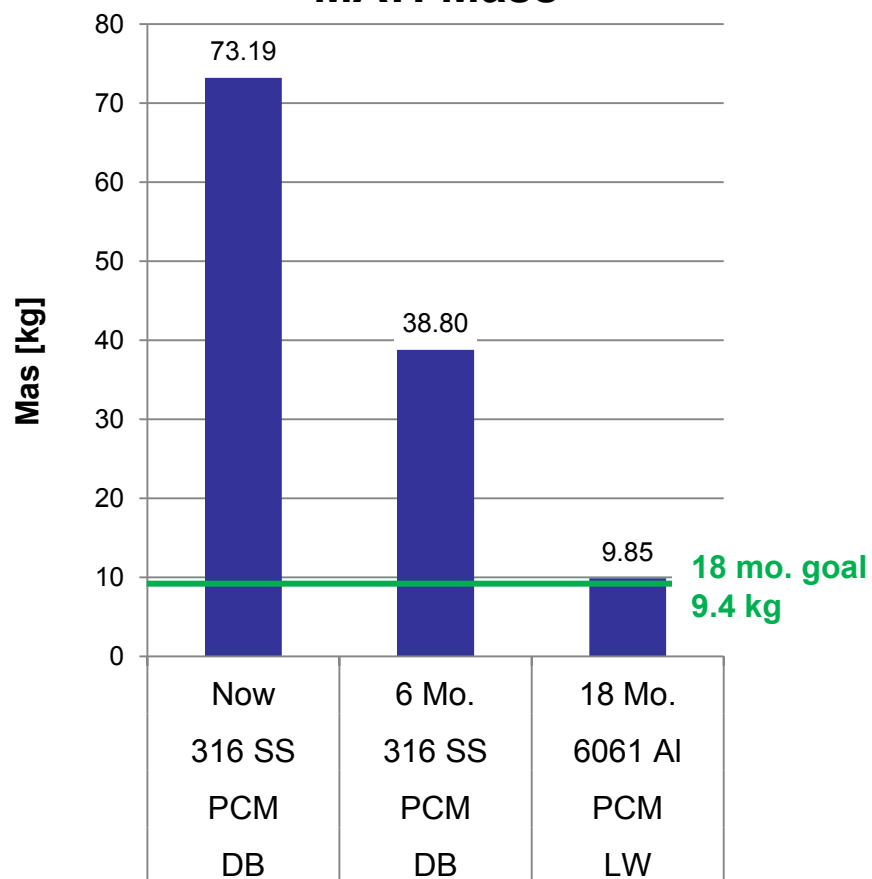



Supplemental Slides - Barrier H - Numbering up of Unit Cells to form a Full Scale Device

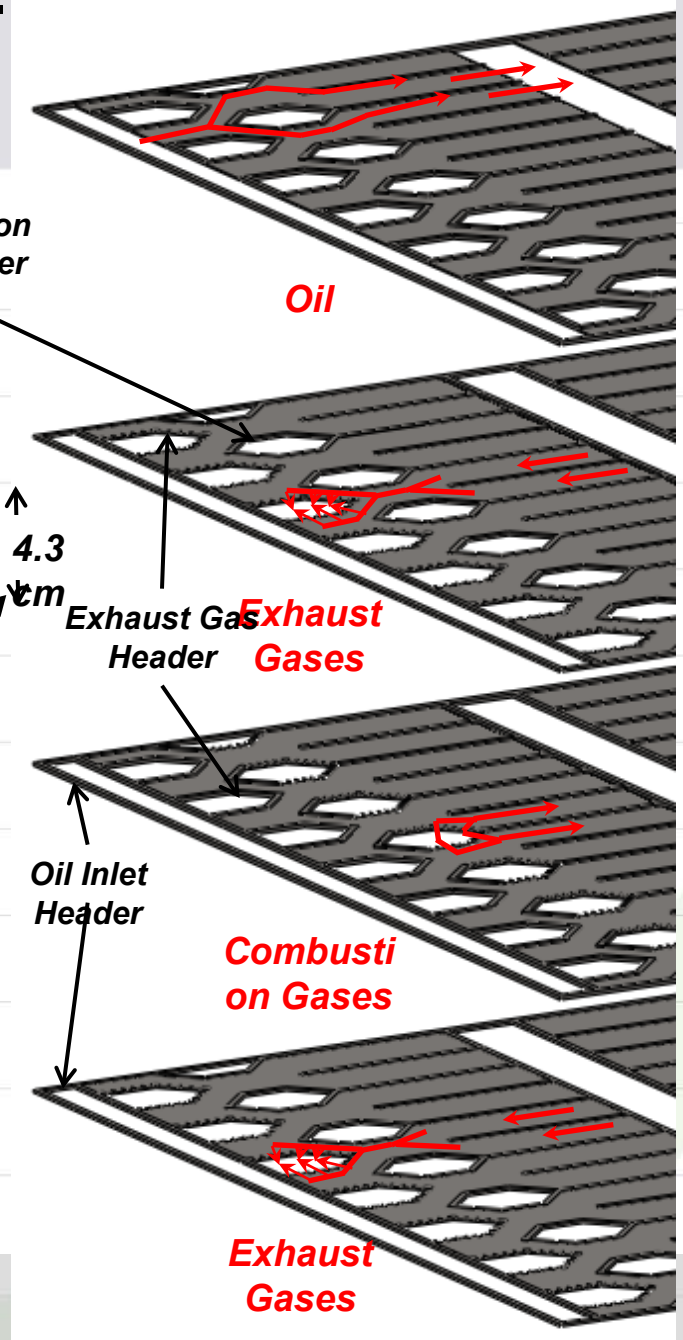
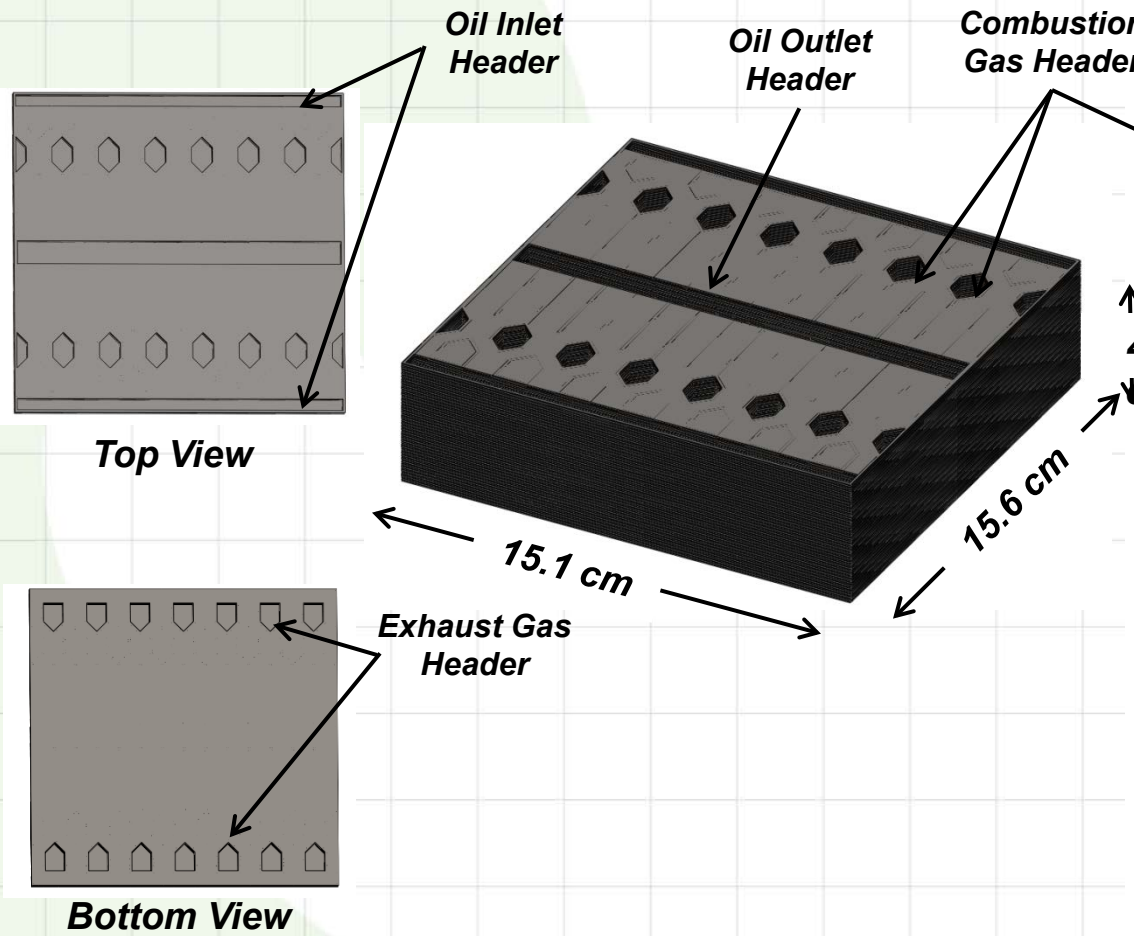



Supplemental Slides - Barrier H Microchannel Combustor-Recuperator-Hydrogen-HX Simulation Results

- Temperature contours (K) for the case: H2 pressure= 5 bar

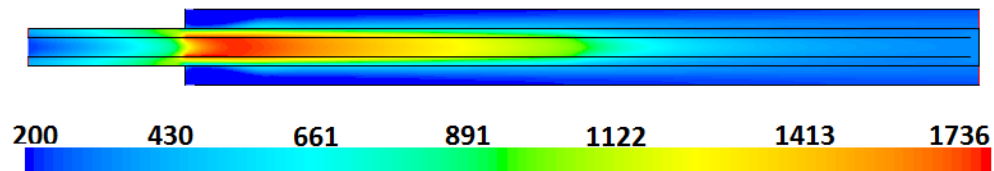

- The desired increase in hydrogen temperature from 200 K to 233 K can be achieved by using less than 0.5% of hydrogen in a system with about 330 unit cells and at efficiencies higher than 92%.
- Assuming 300 μm for wall thicknesses, the total size of the system will be 30 mm 33 mm 15 mm.
- The total size with the headers and 15 mm thick insulations (Pyrogel XT) around the system is: 60 mm 73 mm 55 mm (**0.24 liters**).

H2 mass flow rate (g/s)	H2 pressure (bar)	H2 heated in each unit cell (mg/s)	Number of unit cells	H2 outlet temperature (K)	Exhaust temperature (K)	H2 conversion (in combustor)	Efficiency (%)
2	5	6.127	326	235.7	389.6	99.8%	93.3
	10	6.038	331	236.1	391.5	99.5%	92.9
0.5	5	1.532	326	237.7	391.3	99.8%	92.4
	10	1.528	327	243.8	392.6	99.4%	92.1