

**2012 Hydrogen and Fuel Cells Program Annual Merit
Review Meeting**

Hawaii Hydrogen Power Park

Hawai'i

Richard Rocheleau, Principal Investigator

Mitch Ewan, Program Manager

Hawaii Natural Energy Institute

May 17, 2012

TV009

This presentation does not contain any proprietary, confidential, or otherwise restricted information

Overview

Timeline

- ✓ **Start:** April 2009*
- ✓ **Finish:** Sep 2012
- ✓ **60% Complete**

Budget

- **\$8.4 million**
 - \$1.2 million - DOE
 - \$1.2 million – State of Hawaii
 - *\$1.0 million – NPS for vehicles*
 - *\$300k – State of Hawaii for NPS vehicles*
 - *\$400k – State of Hawaii for MCB Hawaii*
 - *\$1.8 million – ONR – GM Equinox FCV*
 - *\$2.0 million – ONR – 700 Bar upgrade*
 - *\$500k – ONR – SO2 mitigation NPS buses*
- **Funding Received in FY08 - \$2.4 million**
- **Funding Received in FY11 - \$4.2 million**
- **Funding Received in FY11 - \$1.8 million**

Barriers

- ✓ **Validation**
 - A. FCV Performance
 - C. H2 Refueling Infrastructure Data
 - H. Hydrogen from Renewables
- ✓ **Safety**
 - H. Hydrogen Knowledge by AHJ

Partners

- HNEI – Project Lead
- US DOE
- State of Hawaii
- Hawaii Volcanoes National Park (NPS)
- Kilauea Military Camp (DoD)
- Hawaii Ctr. Adv. Transp. Technology (HCATT)
- Hawaiian Electric Light Co (HELCO)
- Sandia National Lab
- Marine Corps Base Hawaii (MCBH)
- Office of Naval Research (ONR)
- *Puna Geothermal Ventures*
- *NREL*

Relevance: Objectives

Project addresses barriers to the widespread deployment of hydrogen vehicles through the deployment of hydrogen infrastructure including 700 Bar “Fast Fill” and novel cascade non-compressor fueling systems.

Power Park project scope expanded in 2011 to support collaboration between USDOE and DOD which includes installation of higher capacity hydrogen infrastructure at the Puna Geothermal facility on island of Hawaii (see MT008) and Office of Naval Research/General Motors fuel cell vehicle demonstration project at Marine Corps Base Hawaii on Oahu.

- ✓ **Support GM Equinox FCV demonstration project on Oahu;**
- ✓ **Install hydrogen fueling infrastructure at Hawaii Volcanoes National Park (HAVO);**
- ✓ **Support the operations of HAVO hydrogen PHEV shuttle buses through to Sep 2014;**
- ✓ **Conduct engineering and economic analysis of HAVO bus operations on different routes, grades, elevations & climatic conditions;**
- ✓ **Validate fuel cell system performance in harsh environment including high SO₂;**
- ✓ **Position HAVO as a hydrogen FCV test bed for NPS; and**
- ✓ **Attract new partners & applications for Big Island hydrogen infrastructure.**

Approach: Tasks & Milestones

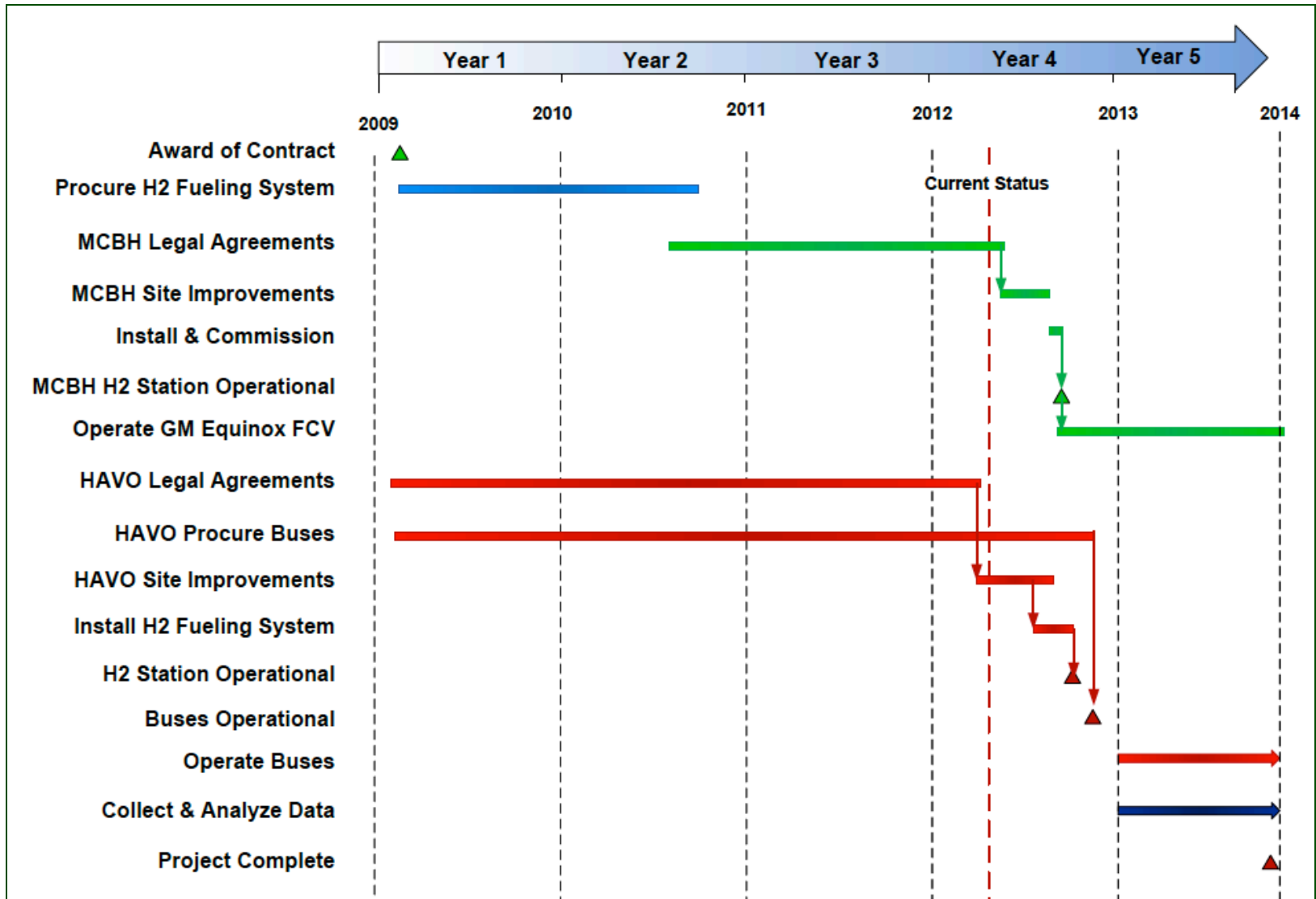

Approach

Reflects expanded scope of project to meet changed circumstances

- ✓ **Leverage DOE/NRL 60 kg/day geothermal to hydrogen grid management project to supply HAVO hydrogen requirements (see MT008);**
- ✓ **Leverage ONR investment (\$1.8 million) in GM vehicles to be operated from MCB Hawaii and other Navy sites on Oahu;**
- ✓ **Leverage National Park Service, State of Hawaii investment, Office of Naval Research in FC-PHEV shuttle buses (NPS \$1 million + SOH \$300k + ONR \$500k) at HAVO;**
- ✓ **Demonstrate SO₂ mitigation technologies and operational techniques to manage impact of high SO₂ on PEM fuel cell performance and durability;**
- ✓ **Install Powertech fueling station at MCB Hawaii on Oahu to support GM Equinox FCV program;**
- ✓ **Use hydrogen produced at Puna Geothermal under DOE/NRL grid management program (MT008) to fuel HAVO buses using high pressure tube trailers and cascade non-compressor dispensing technology;**
- ✓ **Collaborate with existing data analysis groups to compare system data under different operating conditions (fueling stations & vehicles);**
- ✓ **Evaluate the effect of different grades, climatic zones, air quality conditions including SO₂ on vehicle performance;**
- ✓ **Transfer results to industry and government agencies.**

Approach: Hawaii Volcanoes National Park

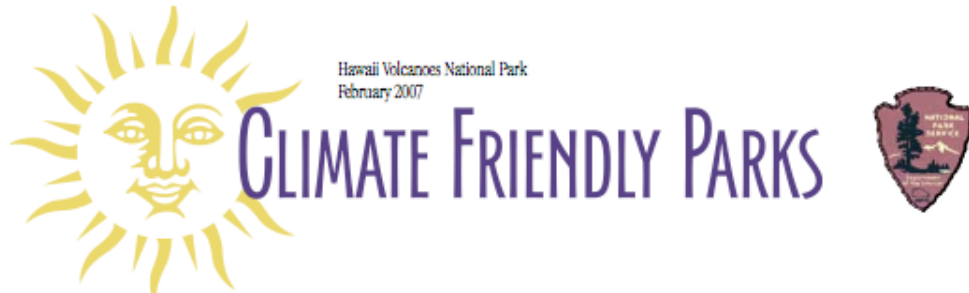

- ✓ **Power Park supports NPS “Climate Friendly Parks” program to reduce carbon footprint & improve visitor experience:**
 - **Reduce traffic congestion- cars and buses;**
 - **Reduce size of buses in the park;**
 - **Reduce emissions pollution; and**
 - **Reduce noise pollution.**
- ✓ **Evaluate performance of plug-in hybrid electric vehicle (PHEV) shuttle buses using hydrogen;**
- ✓ **Test bed for range of NPS transportation solutions.**

Approach: HAVO Hydrogen Fueling Station

- ✓ **Off-site electrolytic hydrogen production using geothermal electricity at the PGM power plant;**
- ✓ **Hydrogen delivered from PGM to HAVO by tube trailer;**
- ✓ **Fueling station sited at Kilauea Military Camp:**
 - **DOD recreational facility located within HAVO;**
 - **KMC to provide shuttle bus operators to support project.**
- ✓ **Investigate novel fueling systems including cascade non-compressor fill.**
 - **Potential to significantly reduce infrastructure cost.**

Approach: Hydrogen Supply



H2-fueled shuttle buses

Hydrogen Dispensing under Grid Management Program



Hydrogen Delivery Trailer uses unique cascade fill process that required no onsite compressor



Hydrogen Dispensing under Hawaii Power Park Program

Geothermal Powered Hydrogen Production



Approach: Hydrogen Delivery Trailer



Powertech permission obtained

3 trailers on order from Powertech

Approach: Powertech H2 Dispensers

MCBH – 350 & 700
Bar dispenser

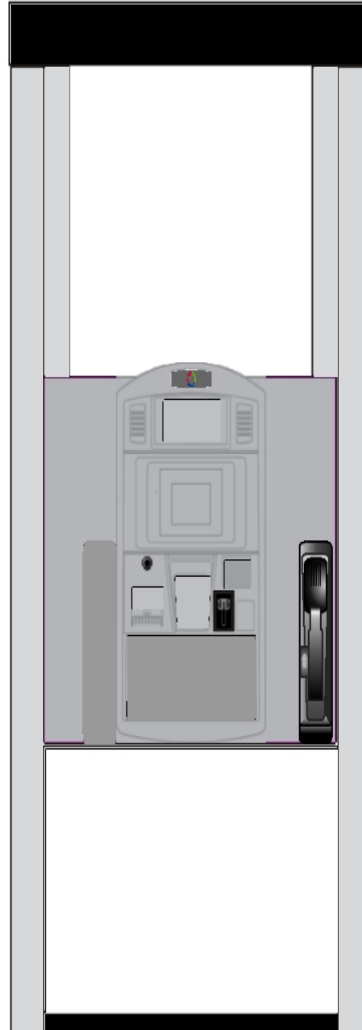

HAVO – Single –
350 Bar

Approach: Station Layout

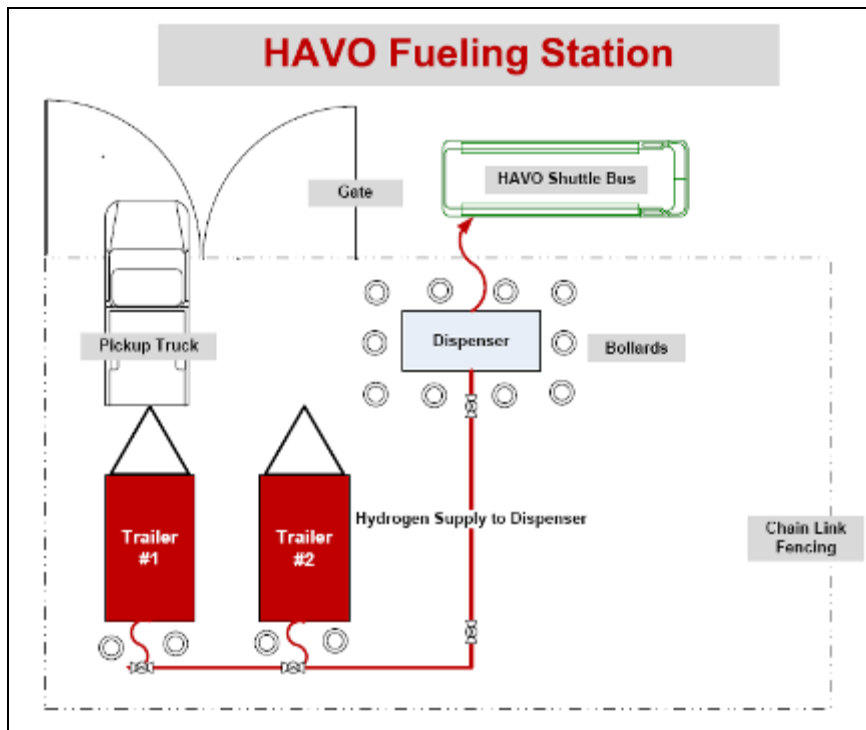

Hydrogen station acoustic level not to exceed 35 dba at 75 meters from closest sleeping quarters.

Location of station showing acoustic specification distance from nearest habitation

Approach: HAVO Bus Routes

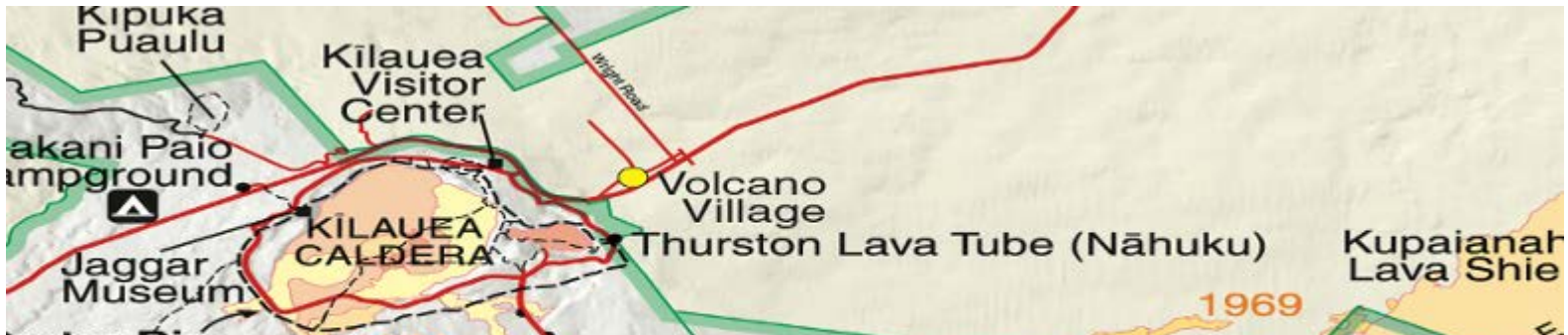

**Crater Rim Drive 11 miles
Elevation 4,000 ft**



**Chain of Craters Road
48 miles round trip
Steep Grades**

**Eruption Site
Elevation Sea Level**

FROG building at eruption site with PV panels to charge bus (pending)



FROG Unit

Hybrid Electric Vehicle Data Analysis



Hickam AFB Bus – Fuel Cell 1

- ✓ **HNEI has extensive experience in electric & hybrid vehicle data acquisition & analysis**
 - 2001 – 2003: Hyundai Santa Fe EV test program
 - 2004 – 2009: Data collection & driving cycle analysis of hybrid FC fleet operated at Hickam AFB
- ✓ **HNEI has ongoing battery evaluation, analysis & simulation projects**
 - 2007 – 2009: Lithium Ion battery cell testing for USAF
- ✓ **HNEI has developed a unique computer modeling framework and GUI for data analysis and driving cycle simulation**

Approach: Vehicle Data Collection

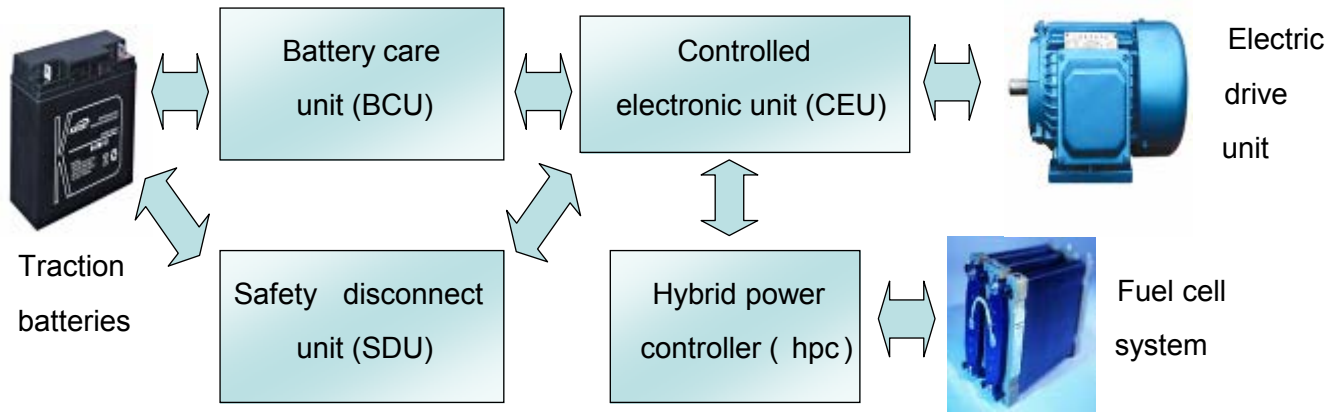

Motor Data

- Motor Voltage (V),
- Requested power (kW),
- Motor speed (RPM),
- Temperature of the motor (°C),
- Operating mode (warming up, motoring),
- Temperature within the CEU box (°C).

Battery Data

- Voltage (V),
- Current (A),
- Power (kW),
- State of charge (%),
- Individual voltage of the modules (V),
- Temperature of sensors within the battery pack (°C)
- Fault status

Fuel Cell Data

- Current density (A),
- Allowed drawn current (A),
- Requested drawn current (A),
- Fuel cell stack voltage (V),
- Coolant temperature (°C).

Hybrid Power Controller Data

- HPC is active – Y/N
- HPC operating mode,
- Voltage of the batteries (V),
- Current delivered to the batteries (A),
- Voltage of the associated fuel cell stack (V),
- HPC fault status.

Approach: Education & Outreach

- ✓ **Over 2 million park visitors annually. Hawaii's biggest tourist attraction;**
- ✓ **HAVO has facilities & team of tour guides dedicated to public outreach;**
- ✓ **Visitor Center theater and interpretation center will host static displays & movie;**
- ✓ **Theater to be powered by 5-kW stationary fuel cell; and**
- ✓ **Park interpreters on shuttle buses to incorporate hydrogen outreach into presentations.**



Approach: Vehicle Supply**

Hawaii

- ✓ Vehicle funding obtained by NPS from Advanced Transportation for Parks and Public Lands program (ATPPL);
- ✓ HCATT supporting conversion of shuttle buses - leverages Air Force Research Laboratory (AFRL) hydrogen vehicle programs.
- ✓ Leverage AFRL Non-Recurring Engineering investment in AF shuttle bus.

Status of Hawaii Vehicles

- ✓ HAVO has prepared specification for supply of 2 conventional shuttle buses;
- ✓ Delivery of retrofit vehicles not expected until late 2012 resulting in major impact to schedule;

Oahu

- ✓ GM supplied Equinox FCVs are onsite on Oahu;
- ✓ Full operation awaiting installation of fueling infrastructure;
- ✓ Supplemental funding (\$1.5 million) received from ONR Feb 2011 to upgrade to 700 bar to meet GM Equinox “fast-fill” requirements.

****Vehicle procurement is outside the scope of Power Park Project**

Partner Roles

- ✓ US DOE – program leadership & funding;
- ✓ HNEI – Program management & implementation;
- ✓ State of Hawaii – cost share & policy support;
- ✓ HAVO & National Park Service:
 - Host site;
 - PHEV vehicles;
 - Education & public outreach.
- ✓ Kilauea Military Camp (DOD):
 - Host fueling infrastructure;
 - Provide bus operators.
- ✓ HCATT – vehicle conversion & technical support;
- ✓ Puna Geothermal Venture – geothermal hydrogen;
- ✓ Office of Naval Research:
 - Lease of 5 GM Equinox vehicles for Marine Corps Base Hawaii;
 - Supplemental funding for 700 bar upgrade to Powertech fueling station.
- ✓ Marine Corps Base Hawaii:
 - Host site for Powertech fueling station;
 - Equinox FCV operator.
- ✓ GM – supplier of 5 Equinox vehicles for MCB Hawaii.



Accomplishments

- ✓ **Re-scoped project to support the GM Hawaii Equinox FCV rollout at MCB Hawaii;**
- ✓ **Completed factory acceptance of Powertech system and demonstrated compatibility with GM Equinox FCV;**
- ✓ **Developing several MOAs among project partners;**
 - **HAVO**
 - **KMC**
 - **MCB Hawaii**
- ✓ **US DOE approved relocating Powertech integrated hydrogen production & dispensing system to MCB Hawaii on Oahu;**
- ✓ **NEPA submission approved for HAVO site**
- ✓ **CATEX approved for Marine Corps Base Hawaii site;**
- ✓ **Issued PO to upgrade Powertech station to 700 bar fast fill;**
- ✓ **Developed infrastructure design for MCB Hawaii;**
- ✓ **Selected contractor to install infrastructure at MCB Hawaii;**
- ✓ **Secured additional \$400k in state funding and \$600k in ONR funding for MCB Hawaii infrastructure and station upgrades.**
- ✓ **Purchased hydrogen delivery tube trailer for use on Oahu;**
- ✓ **Installing dual 350/700 Bar hydrogen dispenser at MCBH.**

Future Work

Oahu

- ✓ Execute remaining MOAs with project partners;
- ✓ Install Powertech system at MCB Hawaii (July 2012);
- ✓ Upgrade Powertech system to 700 bar “Fast-Fill” (Sept 2012).

Hawaii (all 2012 due to vehicle delay outside control of project)

- ✓ Install hydrogen 350 bar dispensing system at HAVO;
- ✓ Deliver geothermal hydrogen to HAVO with tube trailer;
- ✓ Support HAVO bus operations;
- ✓ Collect and analyze fueling station & vehicle data;
- ✓ Seek opportunities for expansion of fleets and/or additional hydrogen infrastructure.

Overcoming Schedule Challenges

- ✓ **Legal issues & agreements are a serious roadblock to progress:**
 - **Legal issues concerning liability & indemnification are imposing serious delays and need to be solved for all DOE hydrogen projects;**
 - **Need to work with insurance industry & legal profession to resolve;**
 - **Public & private sector, including equipment suppliers, need to take on and find solutions to risk issues;**
 - **Legal and insurance costs are significant components of projects and require many man-hours of project staff to resolve issues.**
- ✓ **HAVO & NPS have taken almost 4 years to approve bus procurement!**
- ✓ **UH and MCBH have been negotiating MOA for over 17 months!**

Summary

- ✓ **Leveraging geothermal hydrogen project to increase scope of Power Park;**
- ✓ **PowerTech fueling station being installed at MCB Hawaii & operational by Sep 2012;**
- ✓ **Critical support for GM Equinox FCV rollout in Hawaii;**
- ✓ **HAVO bus procurement and legal agreements continue to present serious schedule challenges;**
- ✓ **Power Park being supported by several agencies including DOE, DOD (Army, Air Force, and ONR), DOI, NPS, State of Hawaii.**
- ✓ **Power Park serves as the cornerstone for expansion of Hawaii “Renewables to Hydrogen” program.**