

Electrolyzer Development for the Cu-Cl Thermochemical Cycle

Michele Lewis

Argonne National Laboratory
Gas Technology Institute
Pennsylvania State University

May 16, 2013

Project ID: PD013

This presentation does not contain any proprietary, confidential, or otherwise restricted information



Overview

Time Line

- Project Start: 10/2006
- Project End: 9/2013*

Budget

- \$2M 2007-2012
- \$375 K for FY13

Technical Barriers

- S. High-Temperature Robust Materials
- T. Coupling Concentrated Solar Energy and Thermochemical Cycles
- W. Materials and Catalysts Development
- X. Chemical Reactor Development and Capital Costs

Partners/Collaborators

- Atomic Energy of Canada Ltd (AECL)
- University of Ontario Institute of Technology (UOIT), lead, for other Canadian universities

*Project continuation and direction determined annually by DOE



Relevance to DOE mission

DOE mission: The hydrogen threshold cost (\$2-\$4/gge dispensed) is a key driver of Hydrogen Production R&D.

- The CuCl cycle is an integrated, solar-driven thermochemical water splitting cycle for producing hydrogen and its R&D is focused on meeting DOE's cost and efficiency targets
- The CuCl cycle couples with the solar power tower, which is near commercialization and provides heat near the 550C required for the highest temperature reaction
- DOE also supports international agreements such as the IPHE and the IEA and leverage technology through international collaboration
 - The CuCl cycle is under development in Canada as one possible method to produce the hydrogen needed to upgrade oil from the tar sands using heat from nuclear power plants and waste heat from cement plants

Approach dictated by results from process design

- Preliminary process design and economics identifies the major cost and energy usage driver as the electrolyzer in the CuCl cycle
- R&D is focused on maximizing performance of the electrolyzer to meet targets in model so that production costs are within range of DOE guidelines
 - **Voltage:** 0.7V (2015) and 0.5V (2025) at current density of 500 mA/cm²
 - Reductions in voltage increase efficiency, increases in current density lower H₂ production costs
 - **Catalyst loading:** 0.3 mg/cm² Pt (2015), 0.2 Pd mg/cm² (2025)
 - **Cu(I) to Cu(II) conversion:** 75% at 118C and 24 bar
 - **Membrane cost:** \$98m² for 2015 and \$58/m²
- Other issues impacting electrolyzer performance that are being addressed
 - Cu crossover, membrane and catalyst durability, lifetime



Approach includes both fundamental and pre-engineering studies

Where	Size, cm ²	Membrane	Test Types and Pt loading on anode and cathode	Temperature, C
PSU	5	Hot pressed Nafion [®] 117	Temperature effects, lifetime tests, membrane durability, EIS and SEM studies to determine degradation mechanisms, Pt loading* <small>*0.8 mg/cm² Pt on both anode and cathode is current loading</small>	30, 80, 100
GTI	300*	CG2N and Nafion [®] 112	Flow rate, holding force, shunt currents, modifications to CG2 One and two-cell stacks, 0.5 mg/cm ² Pt on both anode and cathode* <small>*For consistency with the single cell 300 cm² test</small>	60
GTI	6.45	Supported CG2N	Elimination of Pt on anode 0.5 mg/cm ² Pt on both anode and cathode and only on cathode	80

*The CuCl electrolyzer is significantly different from the conventional water electrolyzer and scale up will be more difficult; Flow rate tests show mass transfer limitations and shunt currents are important because both anolyte and catholyte are conductive.



Approach-Milestones

Month/year	Milestone	Status
09/2012	Operate a 5 cm ² electrolyzer with 95 % current efficiency for 168 h cumulative at 300 mA/cm ² at 0.7 V	Completed
09/2012	Fabricate and test a full size 300 cm ² electrolyzer	Completed
05/2013	Design, build and test an electrolyzer that operates at 100 °C and 1.5 bar to achieve higher current density at 0.7 V	Completed
08/2013	Run single-cell electrolyzer at 0.7 V and 0.5 A/cm ² while using a total of 50 % less platinum than the current 0.8 mg/cm ² Pt loading for each electrode	In progress
08/2013	Operate a 10-cell full-size stack at 0.7 V and 200 mA/cm ² for 100 h and 60 °C	In progress

Schematic of a generic electrolyzer

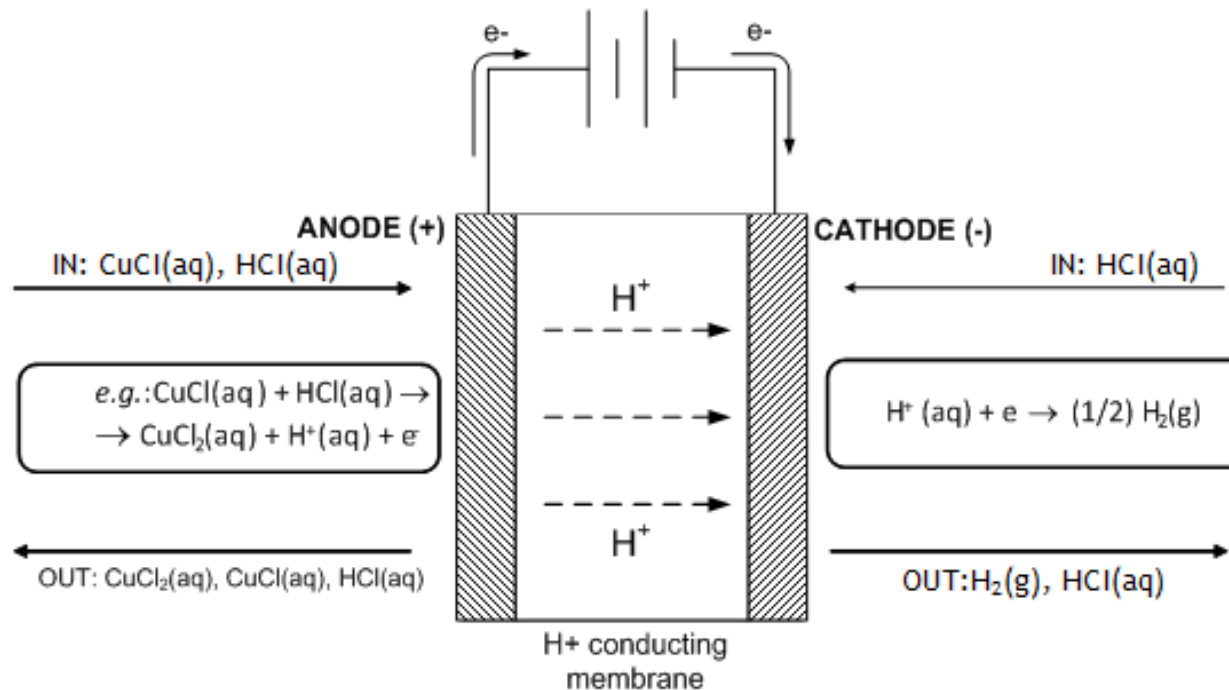

Pennsylvania State University

**Serguei Lvov*, Derek Hall, Richard Schatz,
Sanchit Khurana**

*Contact person



Accomplishment: Current density at or above milestone target in 168 h, 5 cm² electrolyzer test

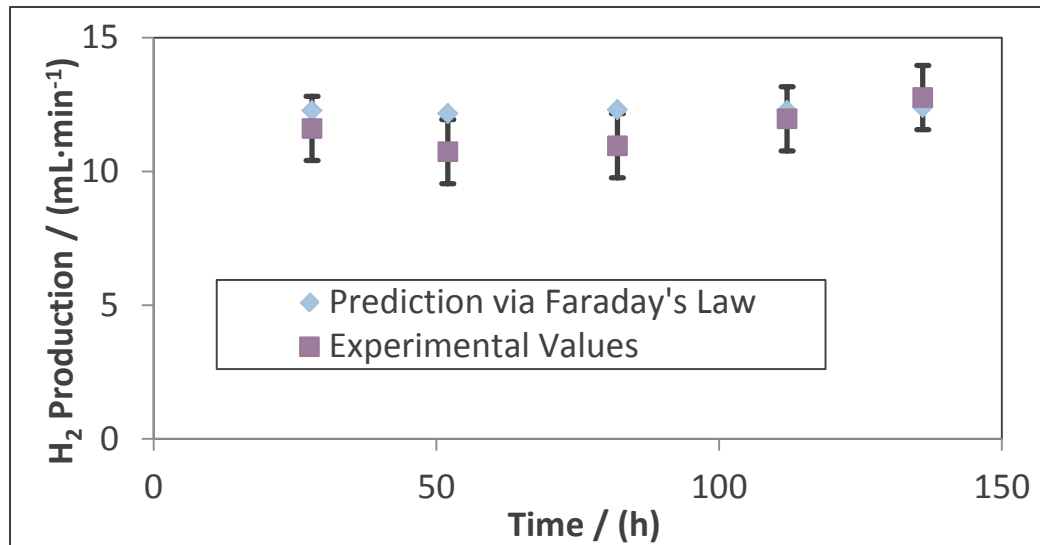
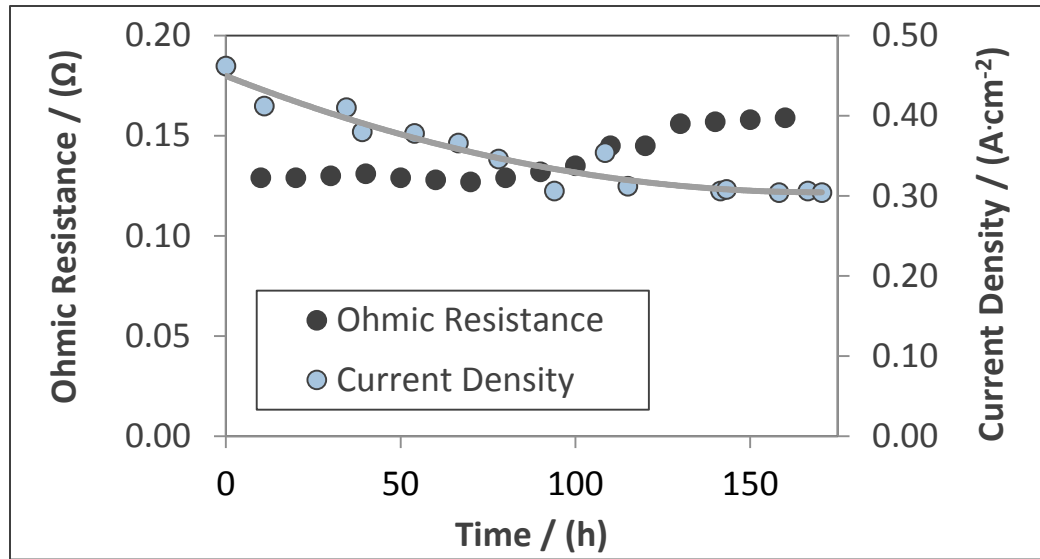

- Current passed through the cell producing H₂ for 168 hours with a minimum current density of 0.3 A/ cm² at 0.7 V; hydrogen production efficiency was 95-100% for the 168 hours of operation
- Solutions were in contact with the membrane for more than 400 hours
- Electrochemical impedance spectroscopy (EIS) was used to characterize electrolyzer processes and degradation mechanisms
- EIS measurements indicate the decrease in current density is due to increased internal ohmic resistance, which suggests membrane degradation

Membrane Single Pressed Nafion® 117, Electrode area 5 cm², Catalyst on each electrode 20% Pt on XC-72R 4 mg·cm⁻², Catalyst loading 0.8 mg·cm⁻² Pt
Temperature 80 °C, Pressure 1 bar, Anolyte 1-2 M CuCl in 6-7 M HCl Catholyte 7 mol/L HCl, Flow rate 230 ml/min

Accomplishment: Electrochemical impedance spectroscopy (EIS) determines dominant resistances in 5 cm² cells

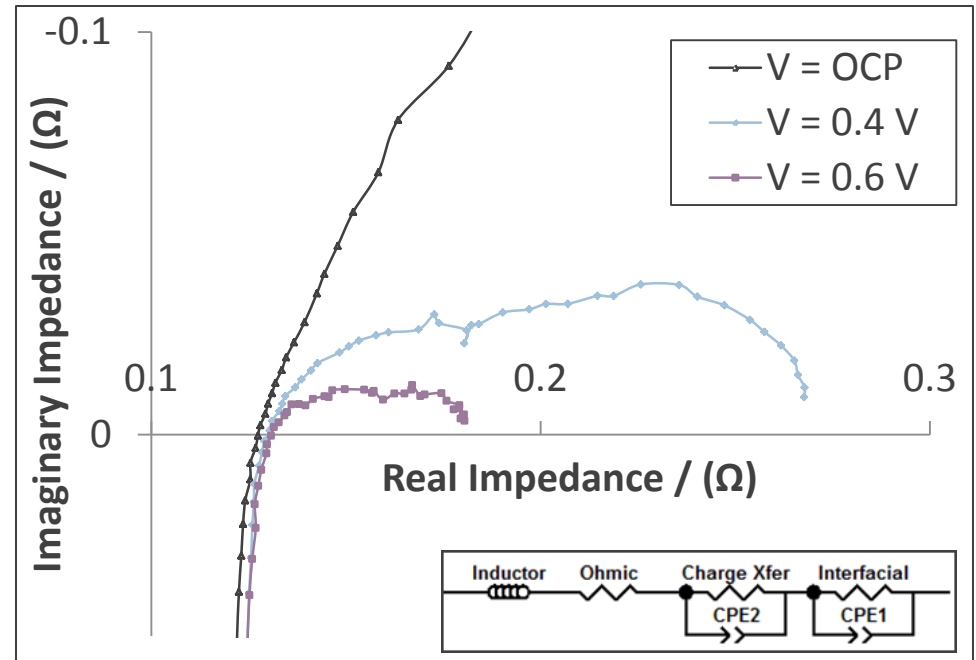
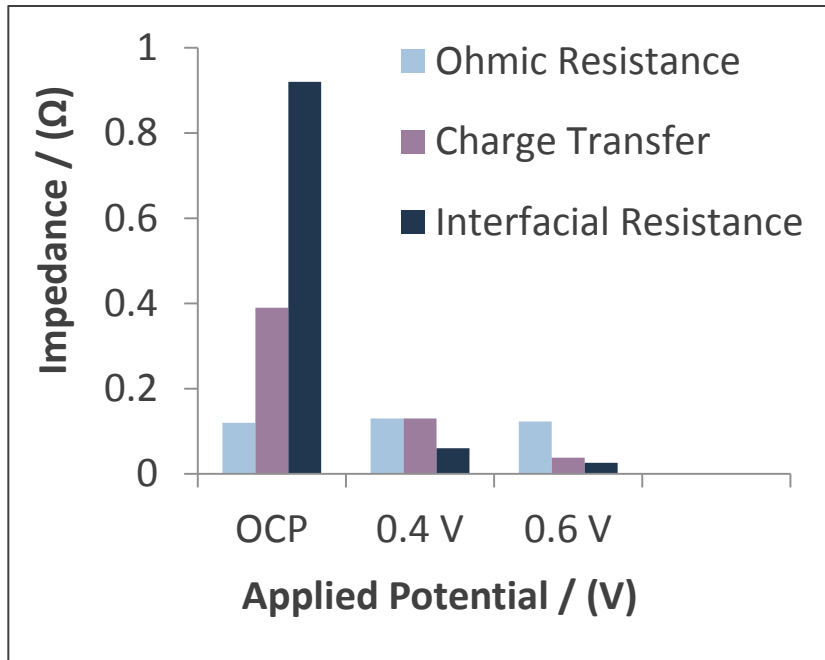

- EIS data taken from the 168-hour test showed that as the applied potential was increased, ohmic resistance was the largest source of impedance
- Better understanding of the dominant resistances at operating conditions allow us to focus on those areas which offer the most potential for improving performance
- Scanning electron microscopy of the electrode surface will also be used to identify possible degradation mechanisms

Temperature 80 °C, Pressure 1 bar, AC potential range 10 mV rms, DC potential 0.22 (OCP), 0.4 and 0.6 V
Frequency range 30,000 to 0.1 Hz

Accomplishment: Current density dependence on T measured

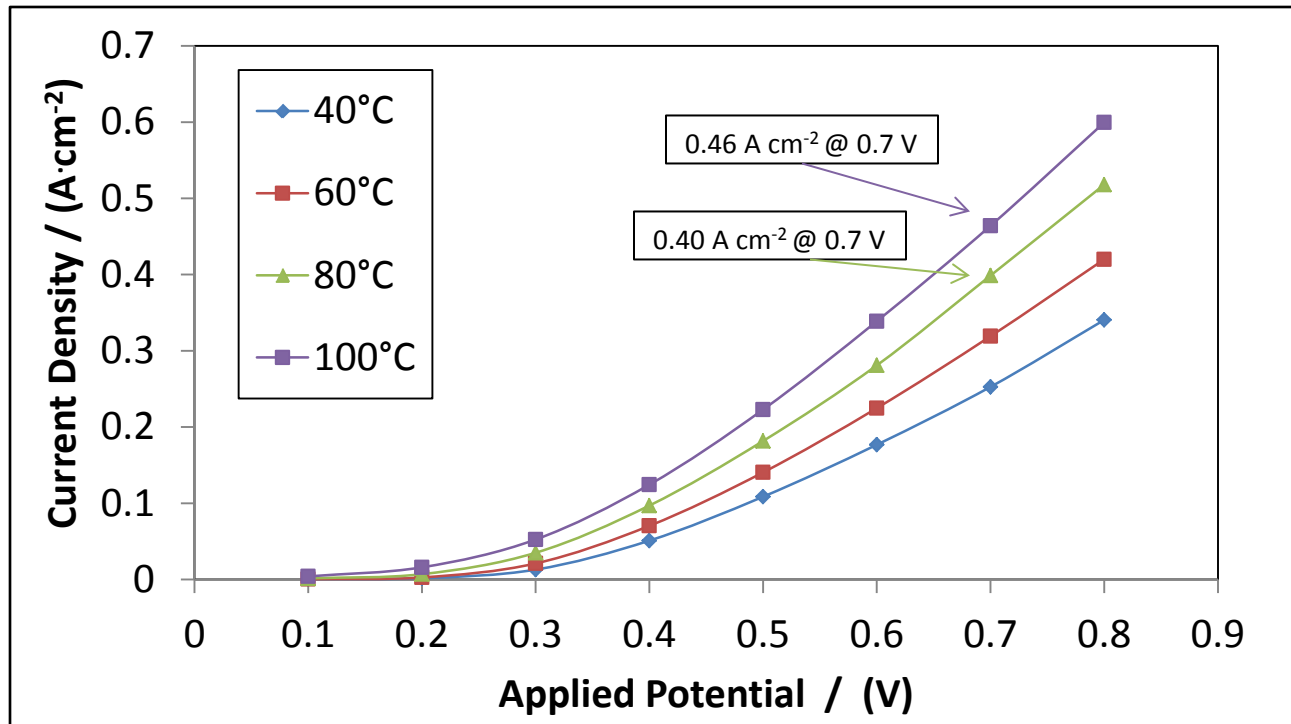

- For every 20C increase in the operating temperature of the 5cm² electrolyzer, the current density increased from 15 to 25 % at an applied potential of 0.7 V
- These results indicate that further increases in operating temperature will result in either higher current densities at 0.7V or a decrease in applied potential for the same current density

Membrane Single Pressed Nafion[®] 117, **Catalyst on each electrode** 20% Pt on XC-72R 4 mg·cm⁻²,
Catalyst loading 0.8 mg·cm⁻², **Pressure** 1-1.3 bar, **Anolyte** 2 M CuCl in 7 M HCl, **Catholyte** 7 M HCl,
Flow rate 230 mL/min

Accomplishments: EIS measurements quantify how ohmic resistance decreases with temperature

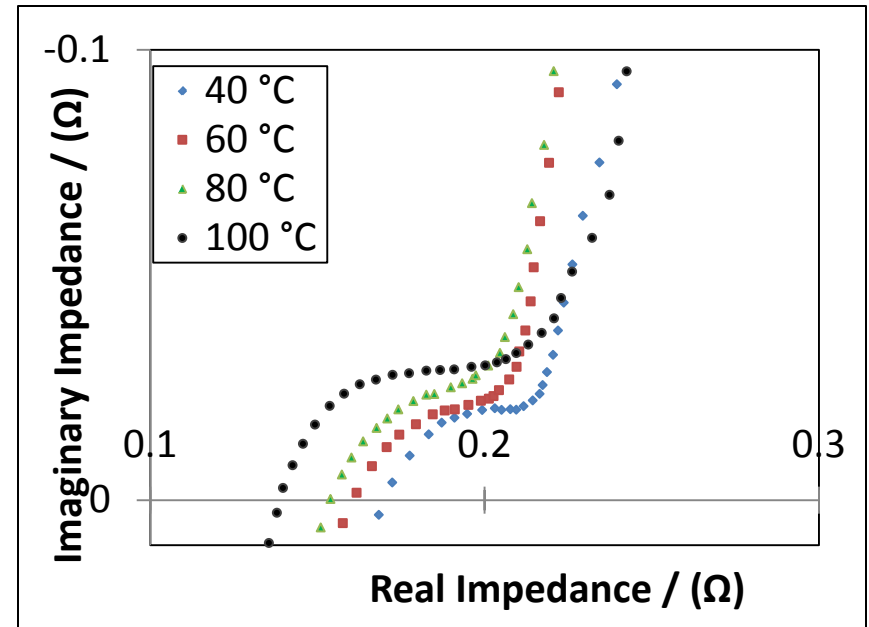
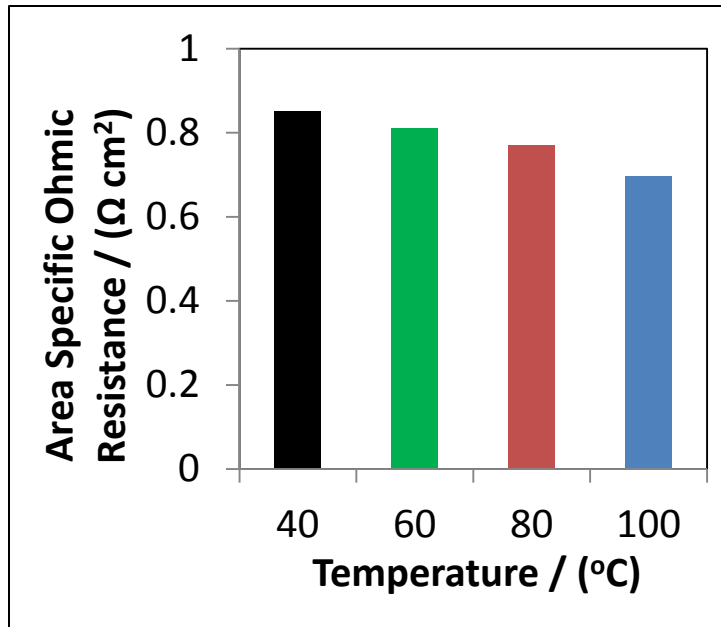

- The ohmic resistance, the value of the real impedance at high frequencies when the imaginary impedance is zero, decreases with increasing temperature
- The decrease in ohmic resistance explained a significant portion of the improved performance when temperature was increased
- The ohmic resistance is mainly due to the membrane resistivity

Temperature 30-100 $^{\circ}\text{C}$, Pressure 1-1.3 bar, AC potential range 10 mV rms, DC potential 0.24, 0.4 and 0.6 V
Frequency range 30,000 to 0.1 Hz

Gas Technology Institute

Chinbay Fan* and Renxuan Liu

*Contact person



Milestone-2012: Single cell 300 cm² electrolyzer tested
Milestone-2013: Fabricate and test 10-cell stack

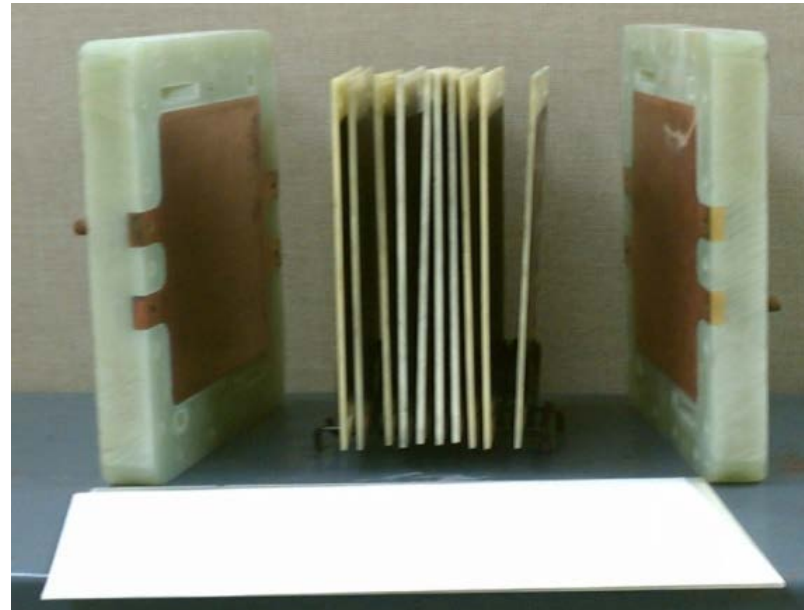
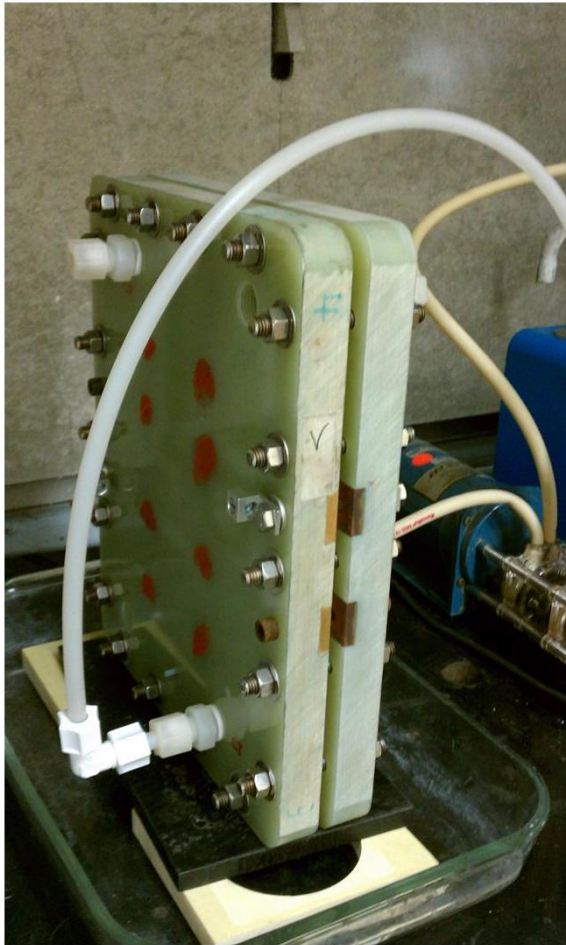

Issues:

1. Sealing of the cells within the stack
2. Evenly distributing the anolyte/catholyte through all the cells in the stack so that each cell has the same mass flow
3. Improving electric contact within each cell
4. Minimizing shunt current within the stack

Accomplishment: 300 cm² cell fabricated and tested at 60°C—operated above H2A design target for 2015(500 mA/cm² at 0.7V)

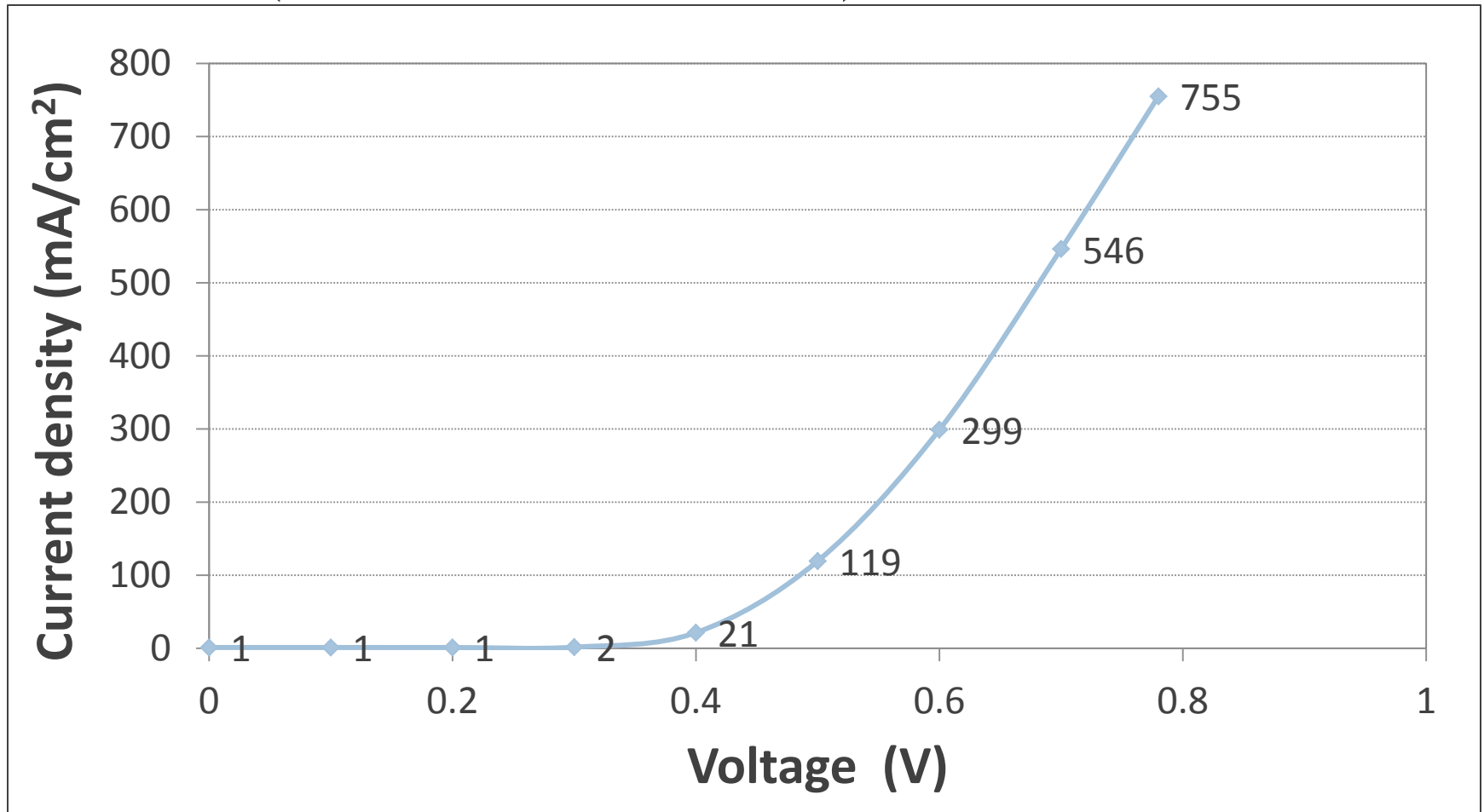

Membrane Nafion® 112, **Catalyst** 0.5 mg/cm² Pt on cathode and anode, **Flow channel design** serpentine channels, anode Pt faces membrane, **Anolyte** 1M CuCl/7MHCl, **Catholyte** 7M HCl, **Temperature** 60°C, **Pressure** 1 bar, **Flow rate** 120 mL/min, **IR: 160.8 mΩ·cm²**



Next step: Fabrication of 2-cell 300 cm² stack

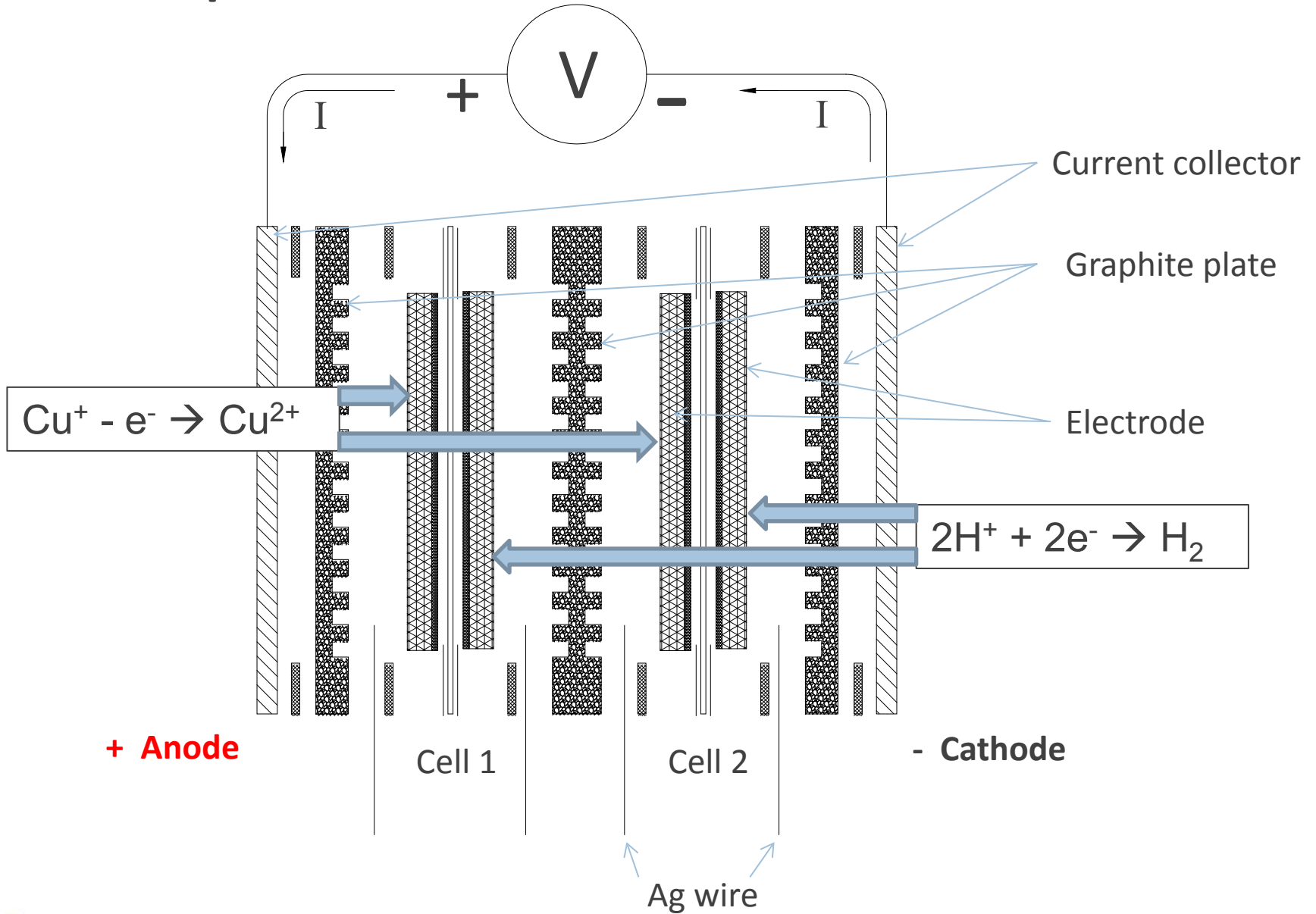

Accomplishment: Performance of 2-cell 300 cm² stack with Nafion[®]112 exceeds 300mA/cm² milestone target at 0.7V

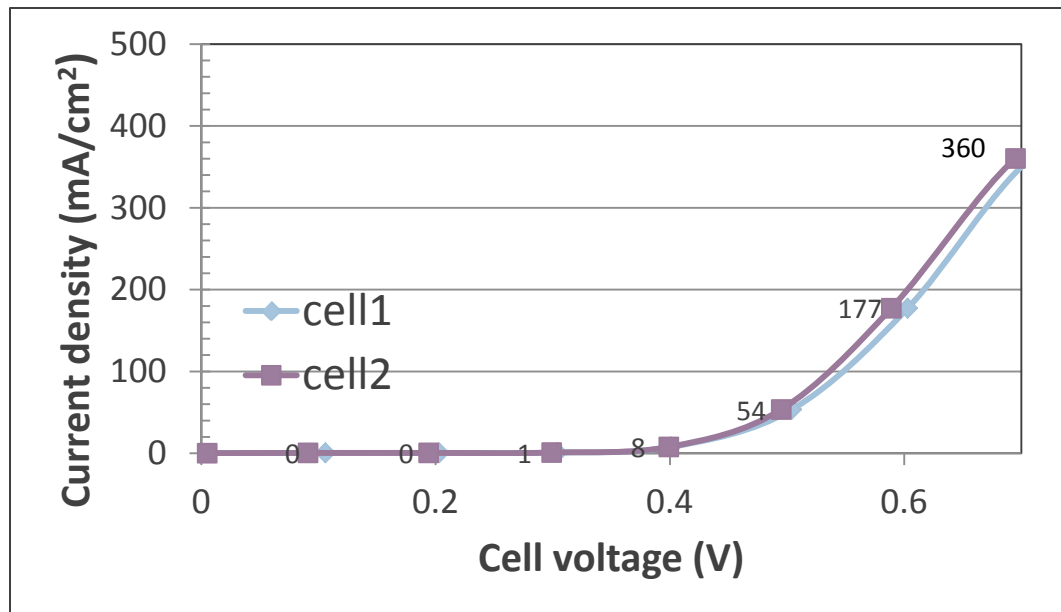

Voltage (V)	Current (mA/cm ²)	Efficiency
0.4	8	83%
0.5	54	90%
0.6	177	98%
0.7	360	98%

- Full size 2-cell stack performance at 0.7V operated at milestone target
- Conversion of Cu(I) → Cu(II) is 65% at 0.7V, close to mass transfer limit
 - A larger flow rate would boost current density for the two cell stack
 - A larger capacity pump has been ordered and is being installed

Membrane Nafion[®] 112, **Catalyst** 0.5 mg/cm² Pt on cathode and anode, **Flow channel design** serpentine channels, anode Pt faces membrane, **Anolyte** 1M CuCl/7MHCl, **Catholyte** 7M HCl, **Temperature** 60°C, **Pressure** 1 bar, **Flow rate** 210 mL/min

Accomplishment: Performance of 2-cell, 300cm² stack with CG2N membrane is stable

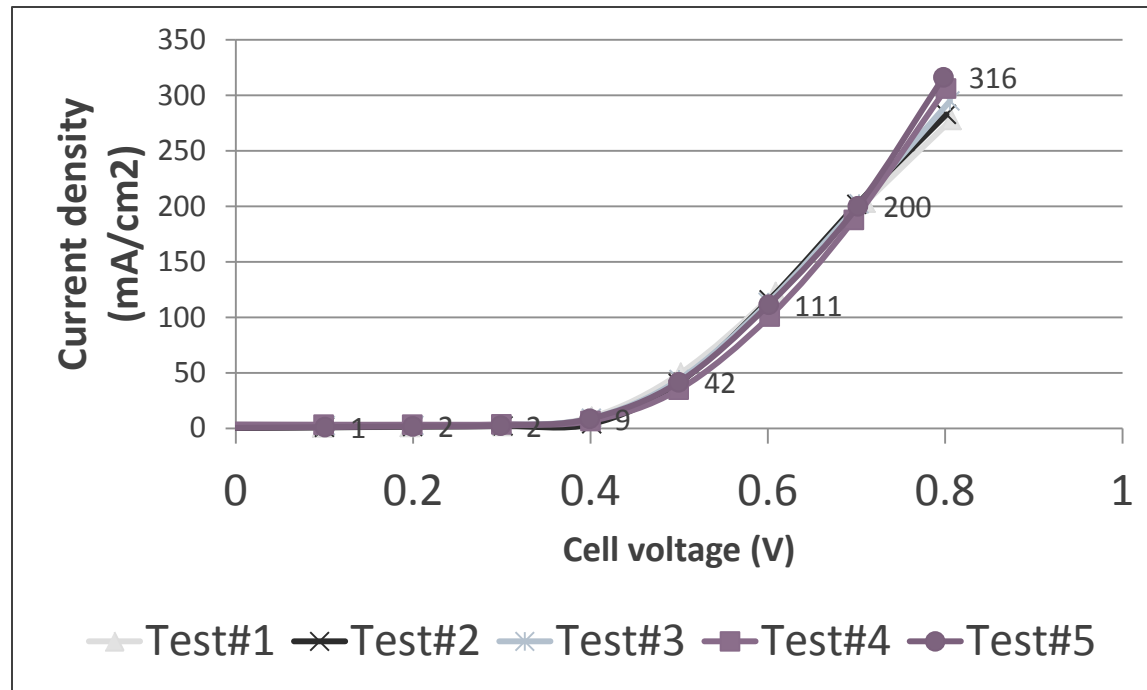

- CG2 costs significantly less than Nafion[®] and is preferred for that reason
 - Current density with the CG2 membrane is stable for the five tests but conversion is 36%
 - Possible reasons are that CG2 is more sensitive to flow rate and is slightly more hydrophobic than Nafion[®]

Membrane modified CG2, **Catalyst** 0.5 mg/cm² Pt on cathode and anode, **Flow channel design** serpentine channels, anode Pt faces membrane, **Anolyte** 1M CuCl/7MHCl, **Catholyte** 7M HCl, **Temperature** 60°C, **Pressure** 1 bar, **Flow rate** 210 mL/min

Accomplishment: Preliminary tests with 1 in² cell show it may be possible to eliminate Pt at the anode

Pt Catalyst		Membrane		Current density at 0.7V(mA/cm ²)
Anode	Cathode	Nafion [®] 112	CG2N	Test 1
x	x	x		405
	x	x		459
x	x		x	350
	x		x	333

- The elimination of catalyst on anode side does not significantly affect performance in these tests
- Small differences in current density are attributable to possible differences in MEA preparation

Summary and conclusions

- 5cm² electrolyzer run successfully for 168 h at milestone value of 300 mA/cm² at 0.7V
 - Degradation in current density was observed as the initial value of 500 mA/cm² gradually decreased to ~300 mA/cm²; EIS studies suggest membrane degradation
- Current densities increased with increasing operating temperature
- One cell 300 cm² electrolyzer with CG2 ran at >500 mA/cm² at 0.7V
- Two-cell stack 300 cm² electrolyzer was tested with both Nafion[®] and CG2
 - Nafion[®]: Operated at >300 mA/cm² at 0.7V and 65% conversion of Cu(I) to Cu(II)
 - CG2: Operated at 200 mA/cm² at 0.7V, achieved only 36% conversion
 - CG2 is sensitive to flow rate and a larger capacity pump is needed (now being installed)
 - CG2 is slightly hydrophobic while Nafion is hydrophilic
- Preliminary tests indicate it may be possible to eliminate Pt catalyst from anode
 - Atomic Energy of Canada Limited reports that their electrolyzer operates consistently without Pt at the anode



Planned work for 2013

- PSU
 - Implement new catalyst application procedure to reduce Pt loading
 - Identify potential replacements for the Pt catalyst
 - Use EIS and other techniques to determine reasons for current density decline in lifetime tests

- PSU and GTI
 - Continue with tests to determine effects of eliminating Pt from the anode
 - Research new electrolyzer flow field designs to reduce mass transfer and interfacial resistances to improve performance
 - Investigate methods and procedures to improve performance and lifetime

- GTI
 - Improve CG2's mechanical stability
 - Increase number of cells in the 300 cm² electrolyzer and study effect of flow rate to improve conversion of Cu(I) to Cu(II)
 - Investigate the possibility of catalyst degradation



Future work

- Operate electrolyzer at 120°C and 20 bar to increase current density at 0.7V (PSU)
- Test newly developed membranes characterized by high conductivity, low Cu permeability high mechanical/thermal stability and low cost (PSU)
- Continue studies to reduce Pt usage (PSU and GTI)
- Optimize flow field designs to improve mass transfer (PSU and GTI)
- Continue lifetime tests, identify mechanisms for performance degradation and develop methods to reduce the effects of these mechanisms (PSU and GTI)
- Continue modification studies of CG2 (GTI)
- Measure the solubility of CuCl_2 , CuCl and their mixtures in highly concentrated (up to 10 mol/L) HCl solutions over a wide range of temperatures up to 100 °C and develop thermodynamic model (PSU)
 - Needed to understand how the spent anolyte will be handled prior to introduction into the subsequent hydrolysis reactor
- Continue development work on the hydrolysis reactor (as funds permit)

Collaborations

- Argonne National Laboratory
 - Shabbir Ahmed and Magali Ferrandon
- Penn State University (PSU)
 - Richard Schatz, Soohyum Kim, Mark Fedkin
- Orion Consulting Group
 - Dave Tatterson
- Consortium of researchers at Atomic Energy of Canada Limited (Sam Suppiah, Lead) and six Canadian universities with University of Ontario Institute of Technology (UOIT) as lead

Activities at AECL and the Canadian universities

- Completed 1000 h lifetime test for the electrolyzer
- Overall objective of the work in the universities is to develop an integrated system
- Identification and testing of corrosion-resistant materials for use as reactors
- Development of new membrane and electrode materials
- Identification of other sources of waste heat that could be used as process heat by co-locating the thermochemical cycle plant near other heat-producing chemical process plants
- Other R&D activities
 - Solubility of CuCl and CuCl_2 in HCl solution
 - Molten salt reactor design
 - Simulations of conceptual integration in hydrolysis and electrolysis steps using Aspen software
 - Crystallization- scale up binary system CuCl_2 and water, ternary system experiments CuCl_2 , HCl and water



Technical back up slides



Relevance to DOE mission

- Objective: Develop a commercially viable process for producing hydrogen that meets DOE cost and efficiency targets using the Cu-Cl thermochemical cycle

- 3 major reactions in cycle

- Electrolysis (simplified)**

- $2\text{CuCl} + 2\text{HCl} \Leftrightarrow 2\text{CuCl}_2 + \text{H}_2$
- Anode: $2\text{Cu}^+ \Leftrightarrow 2\text{Cu}^{2+} + 2\text{e}^-$
- Cathode: $2\text{H}^+ + 2\text{e}^- \Leftrightarrow \text{H}_2$

- Hydrolysis**

- $2\text{CuCl}_2 + \text{H}_2\text{O} \Leftrightarrow \text{Cu}_2\text{OCl}_2 + 2\text{HCl}$

- Oxychloride decomposition**

- $\text{Cu}_2\text{OCl}_2 \Leftrightarrow 2\text{CuCl} + \frac{1}{2}\text{O}_2$

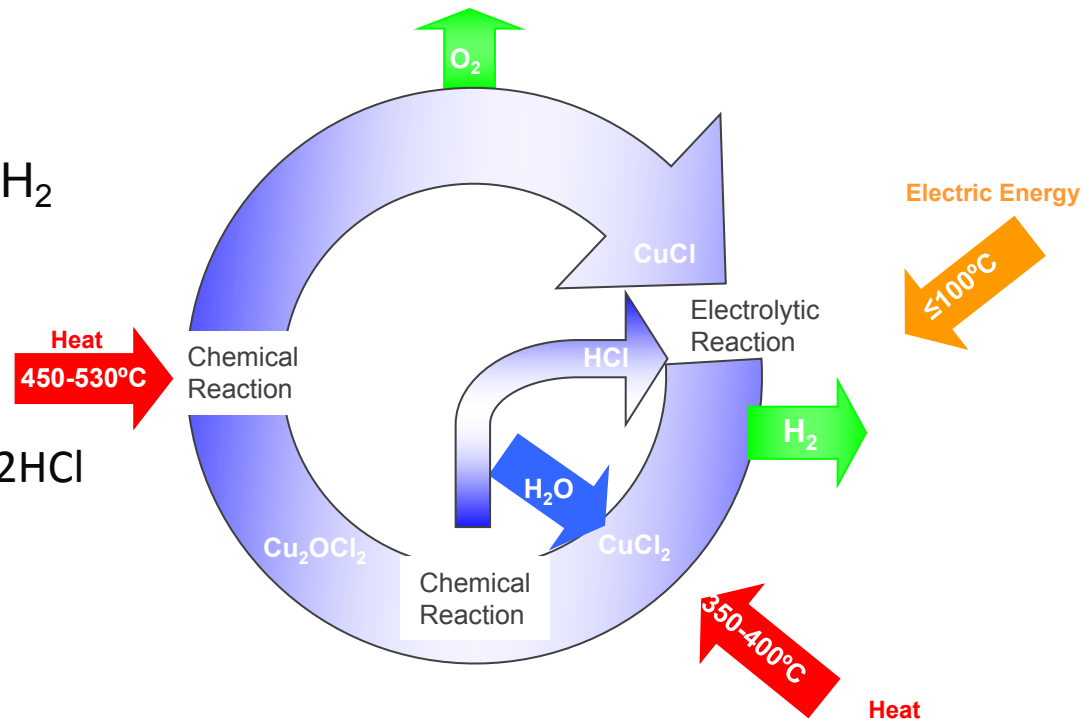

Results: Penn State's single-cell CuCl electrolyzer



Electrolytic cell

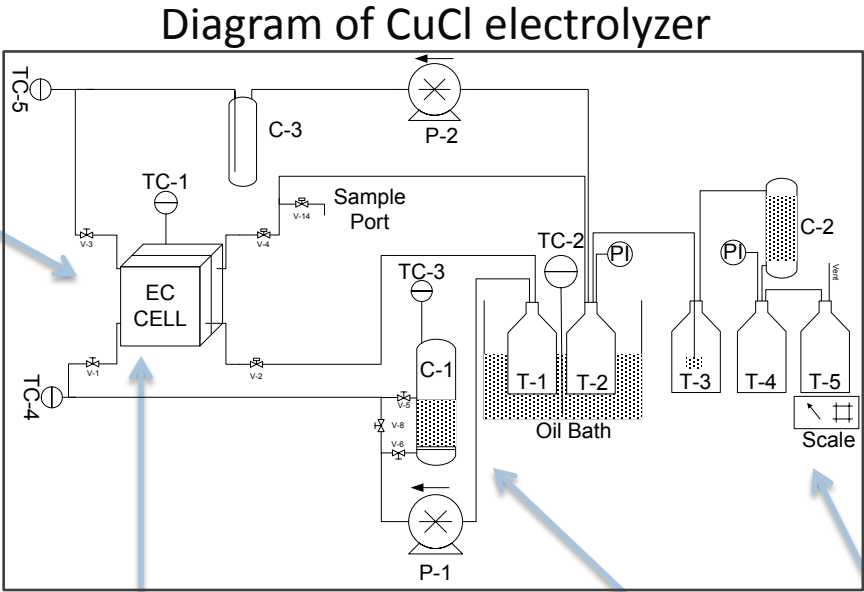
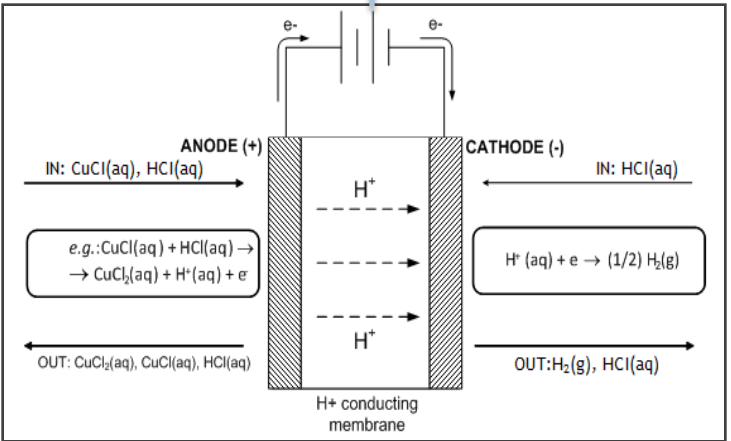

Diagram of CuCl electrolyzer



CuCl electrolyzer



Electrolytic cell diagram

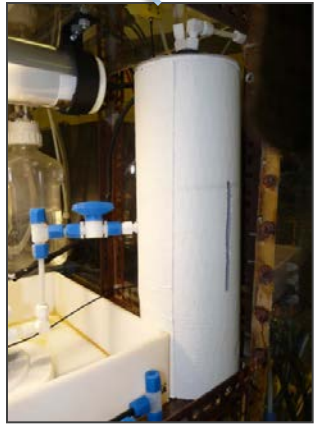

Regeneration column

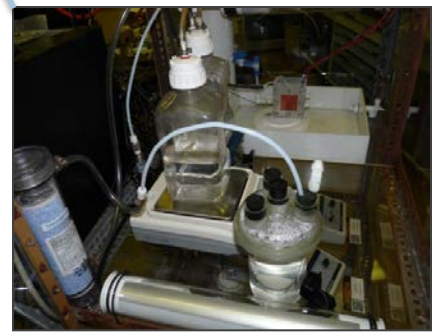

H₂ measuring system



SEM/EDS evidence for the elimination of Cu deposits

- Previous thermodynamic calculations have shown the formation of copper at the cathode should be thermodynamically unfavorable at high concentrations of HCl(aq).
- These calculations took into account the important complex speciation for CuCl(aq) and CuCl₂(aq) in an aqueous phase and non-ideality of the solution components in the highly concentrated HCl (aq) solutions which depends on both the total concentration and temperature.
- The results of SEM and EDS analyses of the electrolyzer cathode surface showed no signs of copper deposition as well.

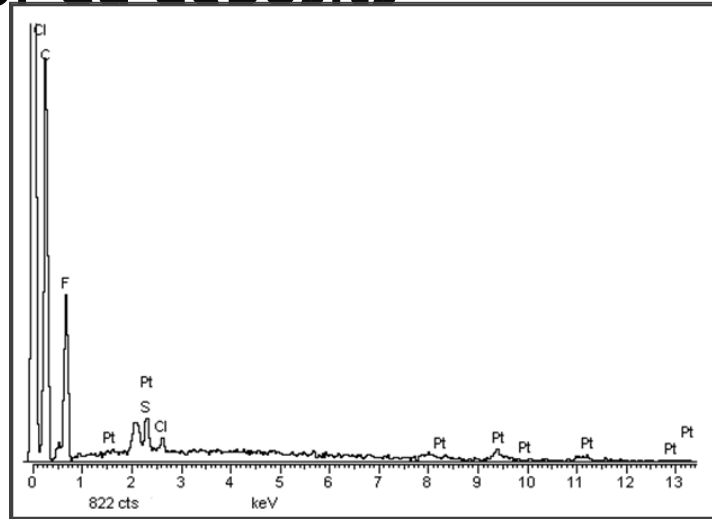

Energy-dispersive X-ray spectroscopy of used cathode

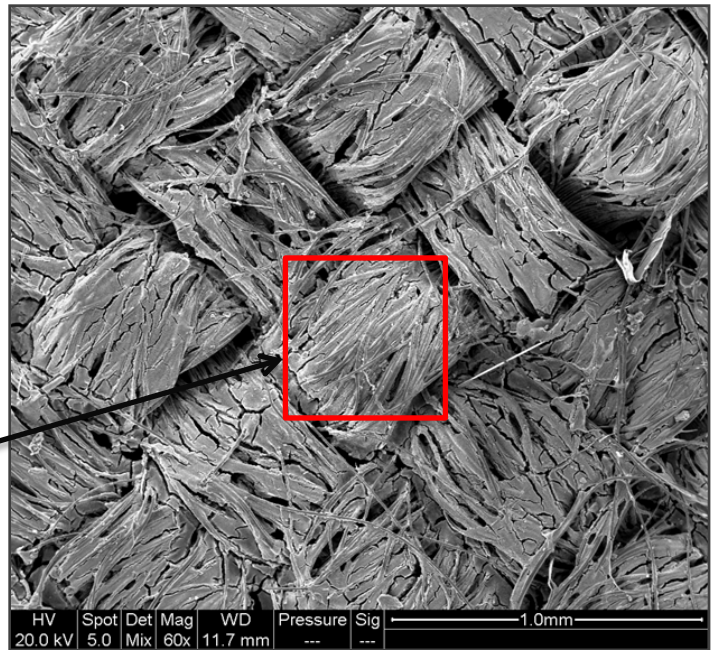

Energy-dispersive X-ray spectroscopy results shown above originated from this region.

Scanning electron microscopy of used cathode

Results from TIAX* study

Case	Capital Investment, \$MM, Solar/Chemical	Cell EMF, V	Electrical Cost,\$/kw	\$/kg of H2	Sensitivity Range, \$/kg	Efficiency, % (LHV)
2 Solar Fields 2015	421/106	0.7	0.068	6.02	4.80-7.11	30
2 Solar Fields 2025	353/89	0.50	0.048	4.43	3.53-5.37	34
1 Solar Field 2025	290/89	0.50	0.048	4.00	3.25-4.81	34

$$\text{Efficiency} = \frac{\text{Kg of H2 Produced} * \text{LHV}}{(\text{External Heat} + \text{Electrochemical work} + \text{Shaft work})}$$

*www.hydrogen.energy.gov/pdfs/progress07/ii_f_1_perret.pdf · PDF file

Results of electrolyzer lifetime tests at AECL

Cell Performance Experiment. Anolyte: 0.5 M CuCl in 11 M HCl,
Catholyte: 11 M HCl, Flow Rates 0.6 L·min⁻¹, Current Density 0.1 A·cm⁻²
T = 45 C

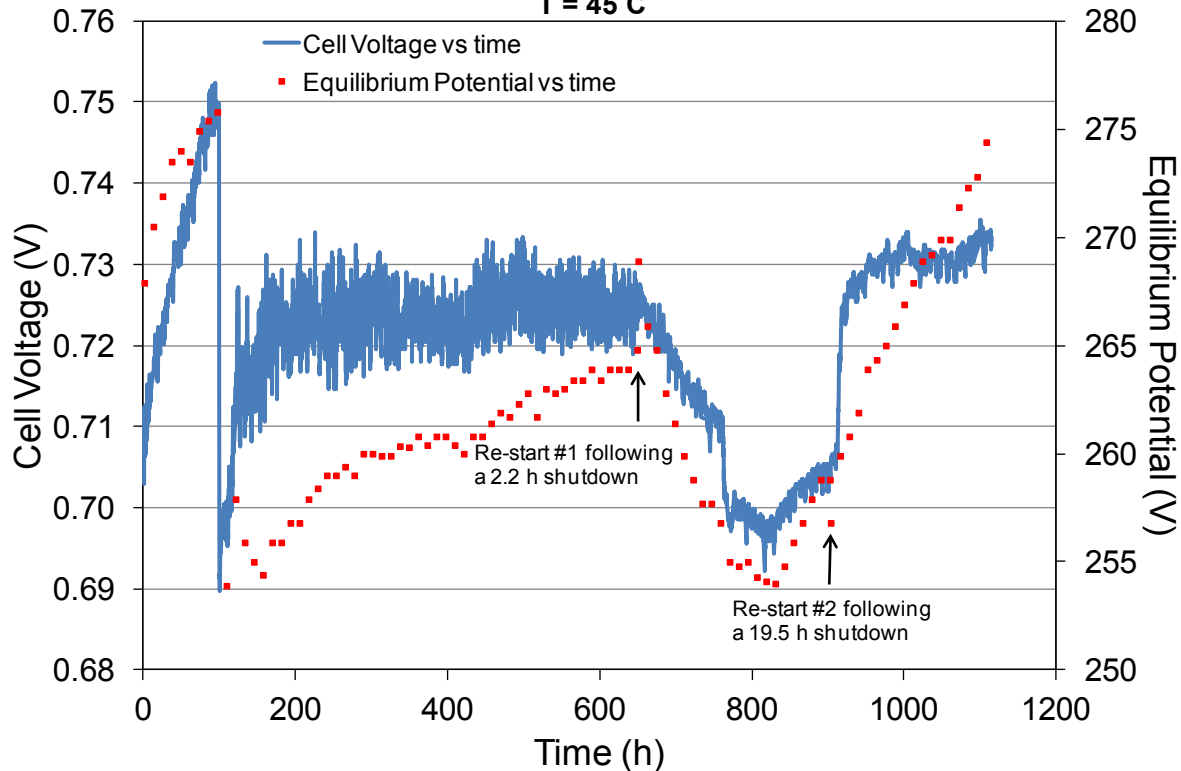

- AECL latest electrolyzer test results show stable performance for about 1000 hours
 - Operating conditions are significantly different compared to those used in the US
 - AECL's results of temperature studies similar to those in the US

