

Component Standard Research & Development

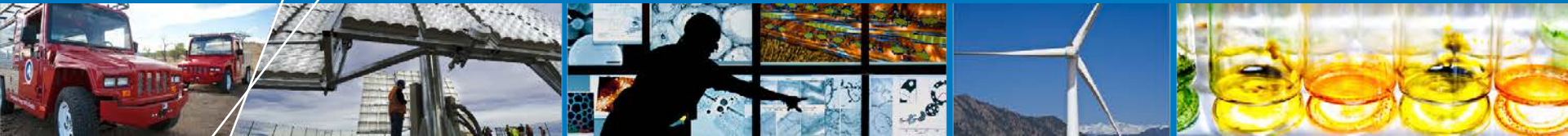

**2013 DOE Annual Merit Review, Hydrogen
Safety Codes and Standards**

**Robert Burgess , William Buttner, Carl
Rivkin, Chad Blake**

National Renewable Energy Laboratory

May 14, 2013

Project ID # SCS002

Overview

T I M E L I N E

- Start date: 2012 , New DOE RD&D Plan
 - Project end date: Oct 2013*
- *Project continuation determined annually by DOE

B U D G E T

- Funding for FY12: **\$500K***
 - Planned funding FY13: **\$150K**
- * Combined funding for Sensor Laboratory and Component Testing

B A R R I E R S

2012 Multiyear RD&D Barriers

- **A.** Safety Data and Information : Limited Access and Availability
- **C.** Safety is Not Always Treated as a Continuous Process
- **F.** Enabling national and international markets requires consistent RCS
- **G.** Insufficient technical data to revise standards
- **H.** Insufficient synchronization of national codes and standards
- **J.** Limited Participation of Business in the Code Development Process
- **K.** No consistent codification plan and process for synchronization of R&D and code development

P A R T N E R S

- Industry (component manufacturers, automotive OEMs, Station suppliers)
- Laboratories/universities (SNL, PNNL, JRC, BAM, NHTSA, NIST, NASA, Battelle, CSM, Powertech, JARI, others)
- Codes & standards development organizations (SAE, CSA, ASME, ISO, UL, NFPA, IEC, GTR, ANSI, others)

Component R&D Relevance

Successful deployment of hydrogen infrastructure will require components that are proven to meet existing safety standards. NREL component R&D test efforts are focused on supporting component manufacturers and system installers.

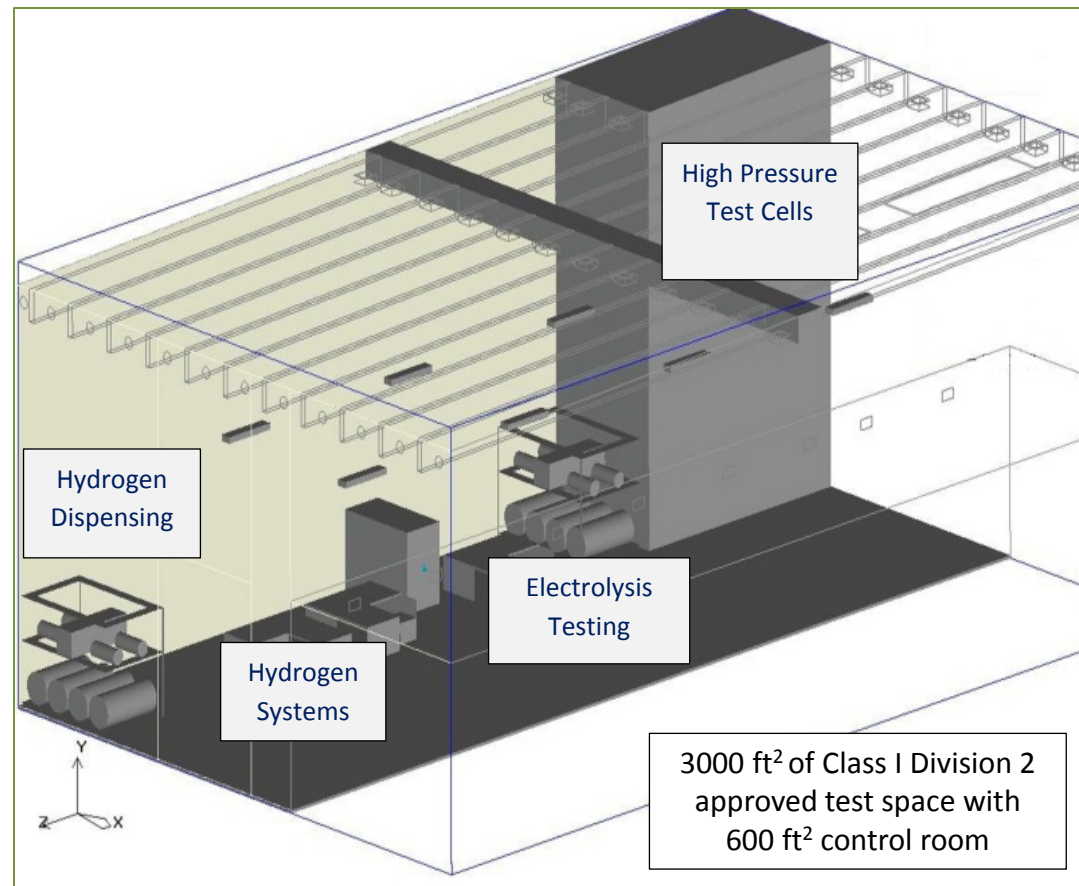

Energy System Integration Laboratory
New laboratory facility in NREL's
ESIF – Energy Systems Integration Facility

Relevance: NREL Tech Val - CDPARRA-MHE-27

Fuel Cell System Safety Reports by Severity and Type

Fuel Cell System Safety Reports by Severity - ARRA and Report Type 2011Q4

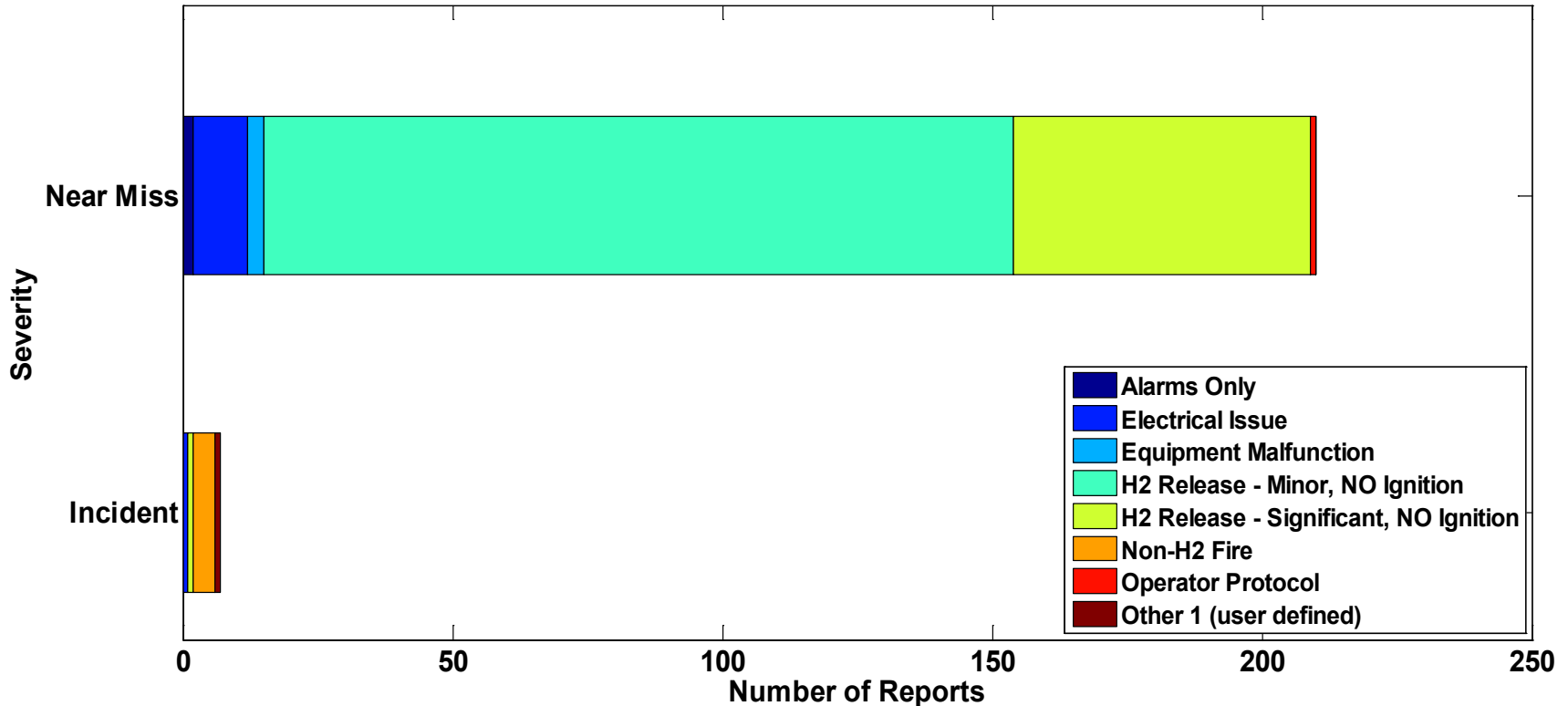

An INCIDENT is an event that results in:

- a lost time accident and/or injury to personnel
- damage/unplanned downtime for project equipment, facilities or property
- impact to the public or environment
- any hydrogen release that unintentionally ignites or is sufficient to sustain a flame if ignited
- release of any volatile, hydrogen containing compound (other than the hydrocarbons used as common fuels)

A NEAR-MISS is:

- an event that under slightly different circumstances could have become an incident
- unplanned H2 release insufficient to sustain a flame



NREL cdparra_mhe_27

Created: Mar-27-12 9:20 AM

Component R&D Approach

Approach	Barrier*
Work closely with codes and standards technical committees to develop test requirements with sound technical basis	G. Insufficient technical data to revise standards K. No consistent codification plan and process for synchronization of R&D and code development
Integrate NREL Technology Validation data with Safety Codes and Standards program needs	C. Safety is Not Always Treated as a Continuous Process
Support hydrogen manufacturers and system suppliers with safety/reliability analysis and testing that can be applied to component certification	F. Enabling national and international markets requires consistent RCS J. Limited Participation of Business in the Code Development Process
Publish technical reports for general use by stakeholders and NREL outreach activities	A. Safety Data and Information: Limited Access and Availability

* Barriers are based on 2012 DOE MYRD&D SCS Section 3.7.5

Component R&D Approach: Test Hierarchy

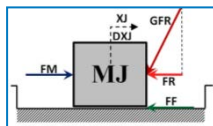
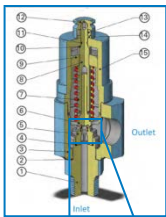
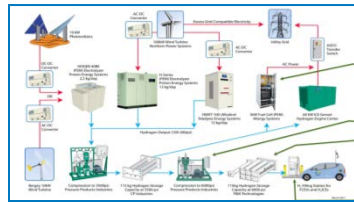

	Description	Advantages	Limitations
System Level Field Testing	Data from hydrogen demonstration and other installations including NREL Technology Validation and NREL wind to hydrogen data.	<ul style="list-style-type: none"> • Large statistical sample size • Actual stresses 	<ul style="list-style-type: none"> • Data fidelity limits • Limited controls on stresses
Component Level Laboratory Testing	Reliability and accelerated life testing at the component level (including production and development hardware)	<ul style="list-style-type: none"> • Actual hardware • Laboratory control of stresses 	<ul style="list-style-type: none"> • Costly multiple sample run • Proprietary issues • Difficult to measure degradation
Sub-Component Laboratory Testing	Reliability and accelerated life testing at the sub-component level (such as check valves used in hydrogen compressors)	<ul style="list-style-type: none"> • Actual hardware • Laboratory control of stresses • Less costly than full component testing 	<ul style="list-style-type: none"> • Costly multiple sample run • Proprietary issues • Difficult to measure degradation
Mechanical Element Testing	Fundamental testing of mechanical element root cause failure modes caused by friction, wear, stress, fatigue and other mechanisms.	<ul style="list-style-type: none"> • Test design flexibility • Statistical sampling • Root cause isolation • Data can be easily shared 	<ul style="list-style-type: none"> • Scaling to component level may be difficult • Special apparatus

Component R&D Accomplishments

- **Codes and standards technical committee support**
 - SAE J2579 balloted as full standard 2012
 - SAE J2601 going to ballot as full standard FY2013
 - NFPA 2 revision cycle
- **DOE Hydrogen Refueling Webinar**
- **Component Testing Report**
 - Integrated approach with NREL Technology Validation
- **ESIF Laboratory Planning**
 - ESIF Hydrogen PHA
 - Five Year Plan
- **Component Outreach Activities: Identifying Technology Gaps**
 - SAE J2601/NFPA 2 Joint Call
 - Emeryville Incident Task Force Participation
 - CA Weights and Measures Project
 - NREL Pressure Safety Panel
 - Non-Metallic Materials Workshop Participation

NREL CDP#72: Difference Between Tank and Ambient Temperature Prior to Refueling

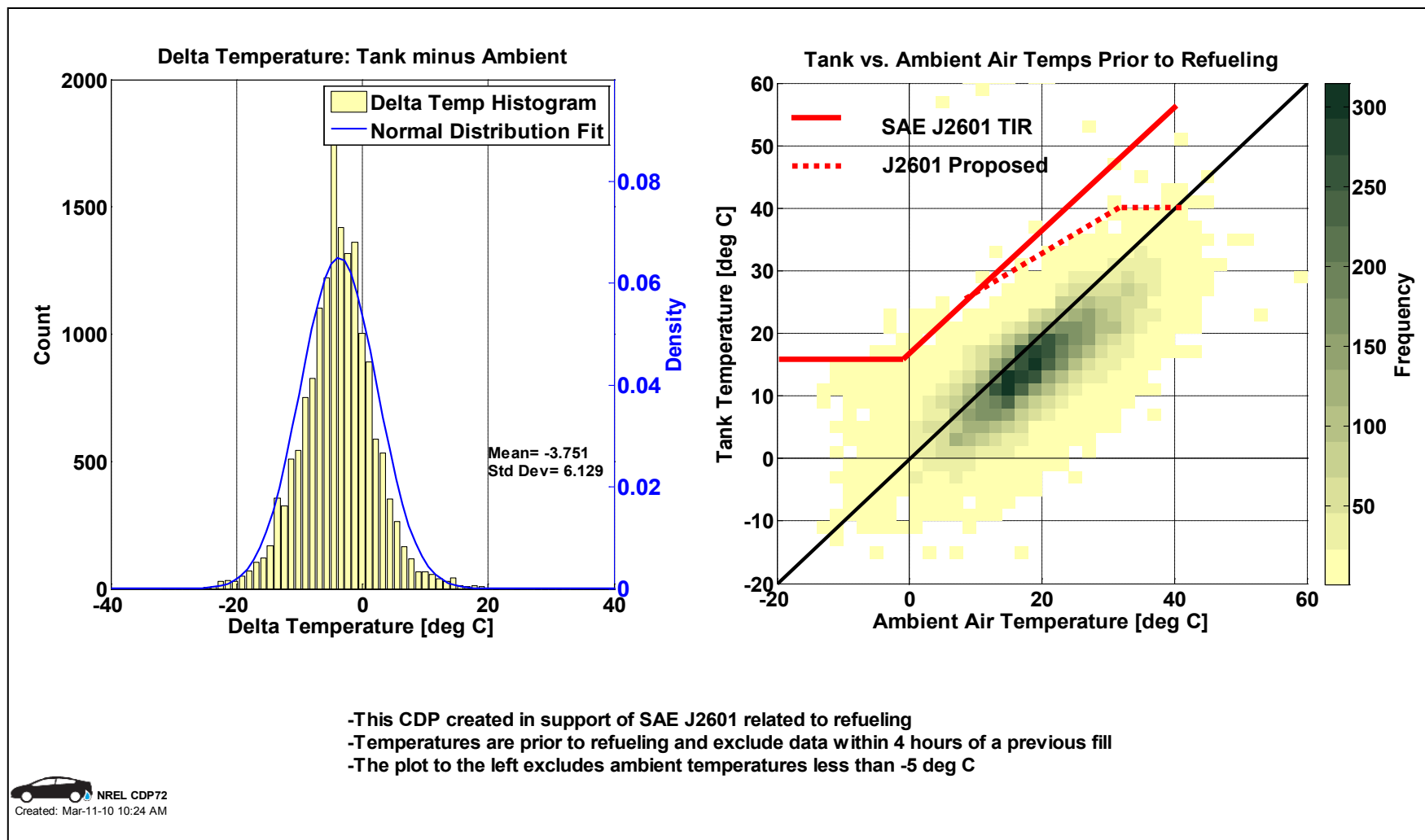

NREL Support of SAE J2601 Hot Soak Technical Basis

NREL - CDP#14: Vehicle Fueling Rates

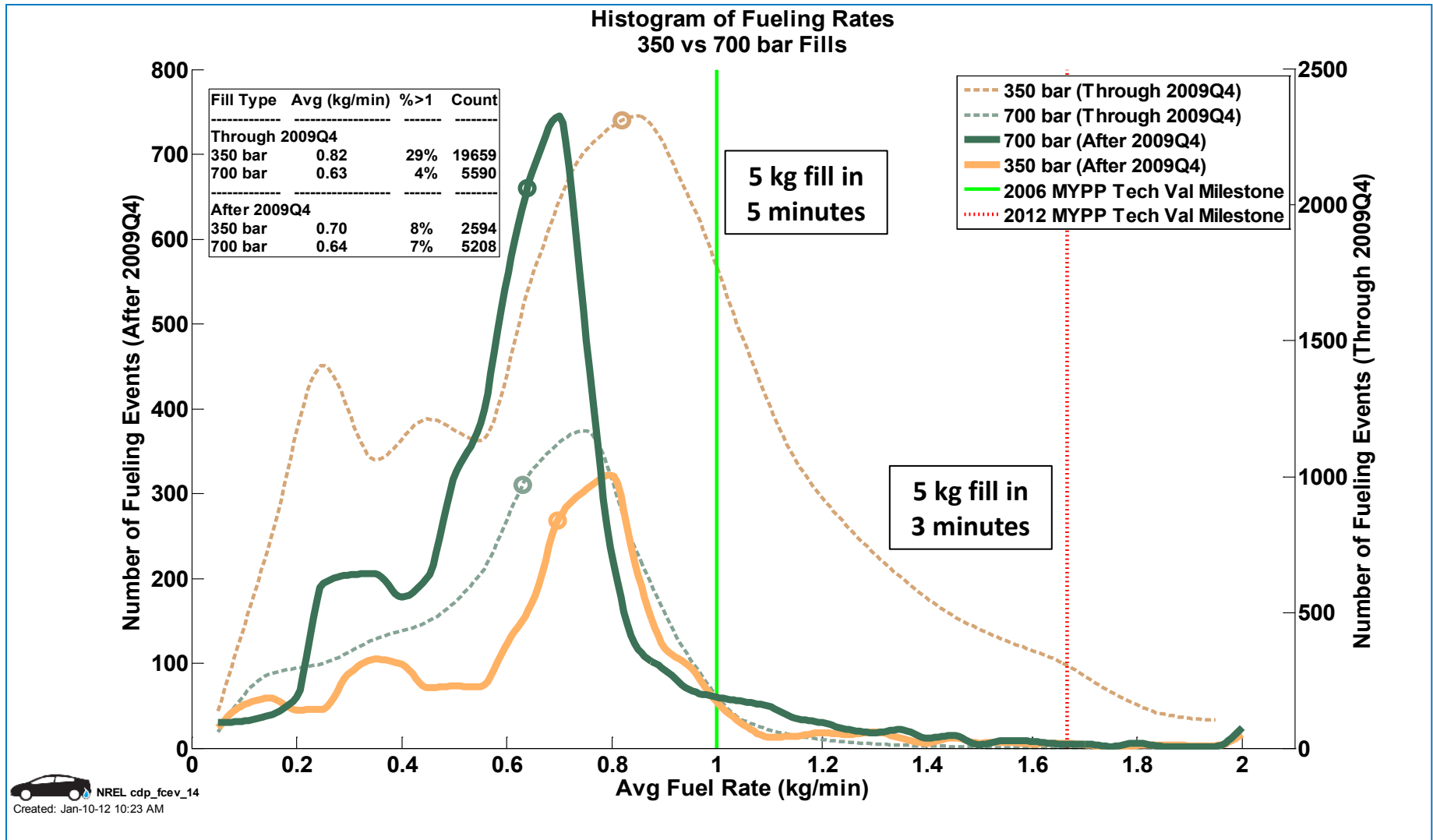

 NREL cdp_fcev_14
Created: Jan-10-12 10:23 AM

New SAE J2601 tables will reduce gaps in DOE fill time targets

Accomplishment : Hydrogen Refueling Protocols Webinar

February 22, 2013

NREL provided support to the DOE EERE Webinar series. Purpose of the webinar is to disseminate information on latest fueling protocols to hydrogen fuel cell vehicle stakeholders. Webinar speakers represent the SAE Interface Technical Committee, discussing the SAE J2601 TIR released document and status on revision to full standard.

U.S. DOE WEBINAR ON H2 FUELING PROTOCOLS: PARTICIPANTS

Rob Burgess	Moderator
Jesse Schneider	TIR J2601, Hydrogen Fueling Guideline
Steve Mathison	Development Fueling-MC Method

Accomplishment : Component Testing Report

Purpose: *To provide summary of recognized hydrogen component issues and present plans for R&D testing required to close technology gaps*

Hydrogen component issues from production, delivery, storage and dispensing have been identified, in some cases through experience with hydrogen demonstration phase projects but in many cases by experience with similar systems in CNG vehicles and other industrial applications.

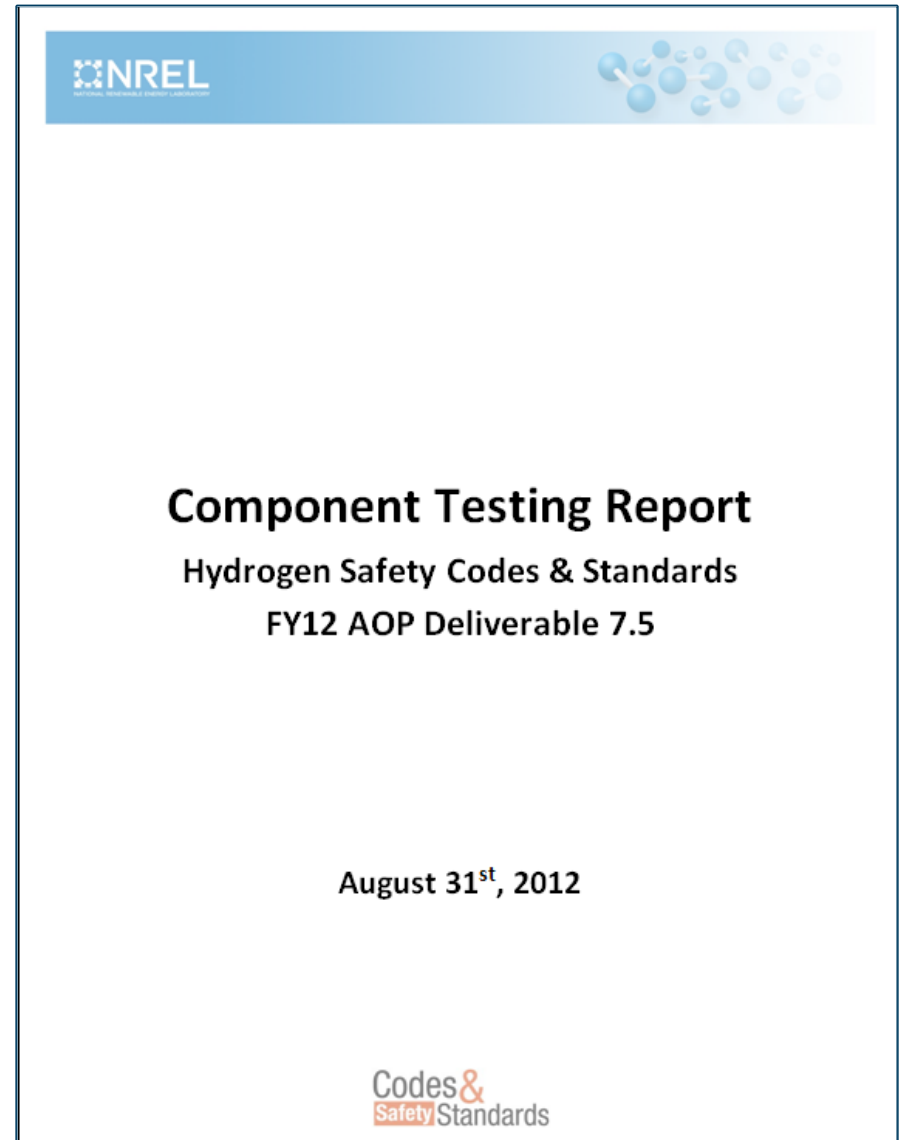

NREL Technology Validation: CDP-MHE-46

Infrastructure Equipment Category of Safety Events

Safety Reports By Equipment Category: Infrastructure

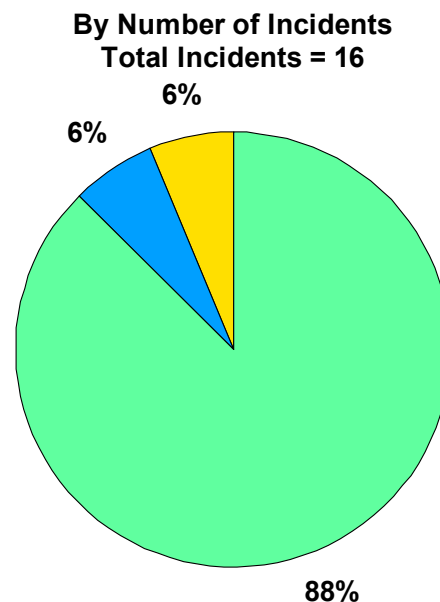
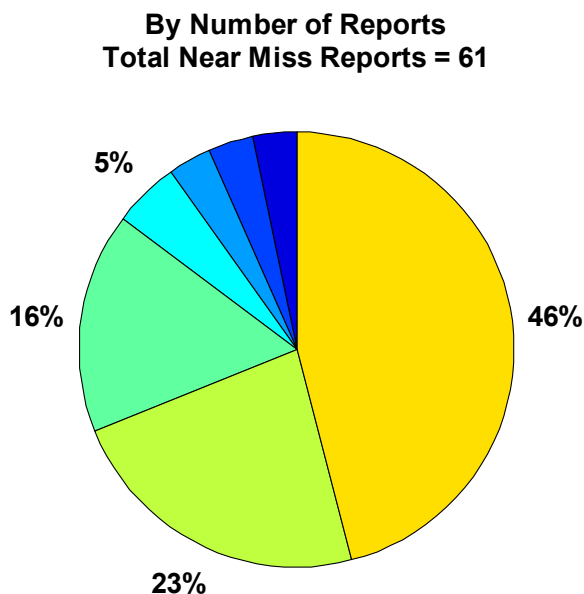

MISC includes the following categories:
FUEL SYSTEM
OTHER

An INCIDENT is an event that results in:

- a lost time accident and/or injury to personnel
- damage/unplanned downtime for project equipment, facilities or property
- impact to the public or environment
- any hydrogen release that unintentionally ignites or is sufficient to sustain a flame if ignited
- release of any volatile, hydrogen containing compound (other than the hydrocarbons used as common fuels)

A NEAR-MISS is:

- an event that under slightly different circumstances could have become an incident
- unplanned H2 release insufficient to sustain a flame

NREL Component Test Report uses Technology Validation Data

SAE J2601/NFPA 2 Joint Call

- **Outreach activity requested by SAE J2601 technical committee to guide enforceable code language**
 - SAE J2601 “Fueling Protocols for Light Duty Gaseous Hydrogen Surface Vehicles”, draft document is undergoing significant revision from TIR (Technical Information Report) to release as full standard
 - Subgroup created with responsibility for text revision
- **NFPA 2 revision cycle for fall 2014**
 - Public input closing date was: January 4th 2013
 - Technical Committee Meeting June 4th-7th 2013, Quincy MA
 - Public comment closing data: November 15th 2013

Investigation Team: Emeryville Incident

Investigation team was established at CARB's request and included participation from the following organizations

- Sandia,
- NREL
- PNNL
- DOE
- Hydrogen Consultants

SANDIA REPORT

SAND2012-5170
Unlimited Release
Printed June 2012

Investigation of the Hydrogen Release Incident at the AC Transit Emeryville Facility

Aaron P. Harris (Sandia National Laboratories)
Chris W. San Marchi (Sandia National Laboratories)

Prepared by
Sandia National Laboratories
Albuquerque, New Mexico 87185 and Livermore, California 94550

Sandia National Laboratories is a multi-program laboratory managed and operated by Sandia Corporation, a wholly owned subsidiary of Lockheed Martin Corporation, for the U.S. Department of Energy's National Nuclear Security Administration under contract DE-AC04-94AL55000.

Approved for public release; further dissemination unlimited.

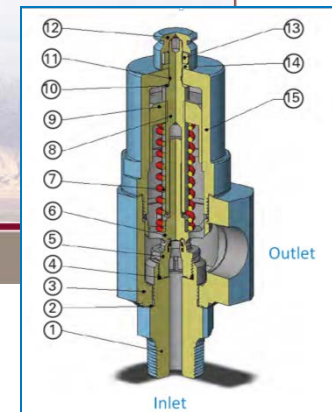

NREL has several relief valves of identical build to the Emeryville valves. These valves are designated for failure mode validation testing

NREL Component Collaborations

- Codes and Standards Development Organizations - SAE, CSA, ASME, ISO, UL, NFPA, IEC, GTR, ANSI, others
- Laboratories/universities - SNL, PNNL, JRC, BAM, NHTSA, NIST, NASA, Battelle, CSM, Powertech, JARI, others
- CRADA (Cooperative Research and Development Agreement) in place with compressor manufacturer
- Technology Validation program for systems level safety/reliability integration

Future Test Priorities

- **Compressor Reliability**
 - Root cause MTBF (Mean Time Between Failure) analysis and experimental study
- **Materials of Construction in Hydrogen Service**
 - Emeryville pressure relief device extended service pressure testing
- **Flow Meter Accuracy**
 - Partner with manufacturers in developing solutions to dispensed hydrogen metering accuracy
- **Hose Reliability**
 - Failure mode investigation of existing dispenser hose designs and accelerated life testing
- **Receptacle Wear & Nozzle Durability Study**
 - Accelerated life testing , extending CNG results to hydrogen operating conditions
- **Low Temperature Sealing**
 - Mechanical element testing of seal designs at pressure and temperature limits



NREL Designed Gravimetric/Volumetric Hydrogen Dispensing Apparatus

Component testing is being coordinated through multiple subprograms to leverage NREL's core capabilities

ESIF Component Test Utilization

Energy Systems Integration Facility

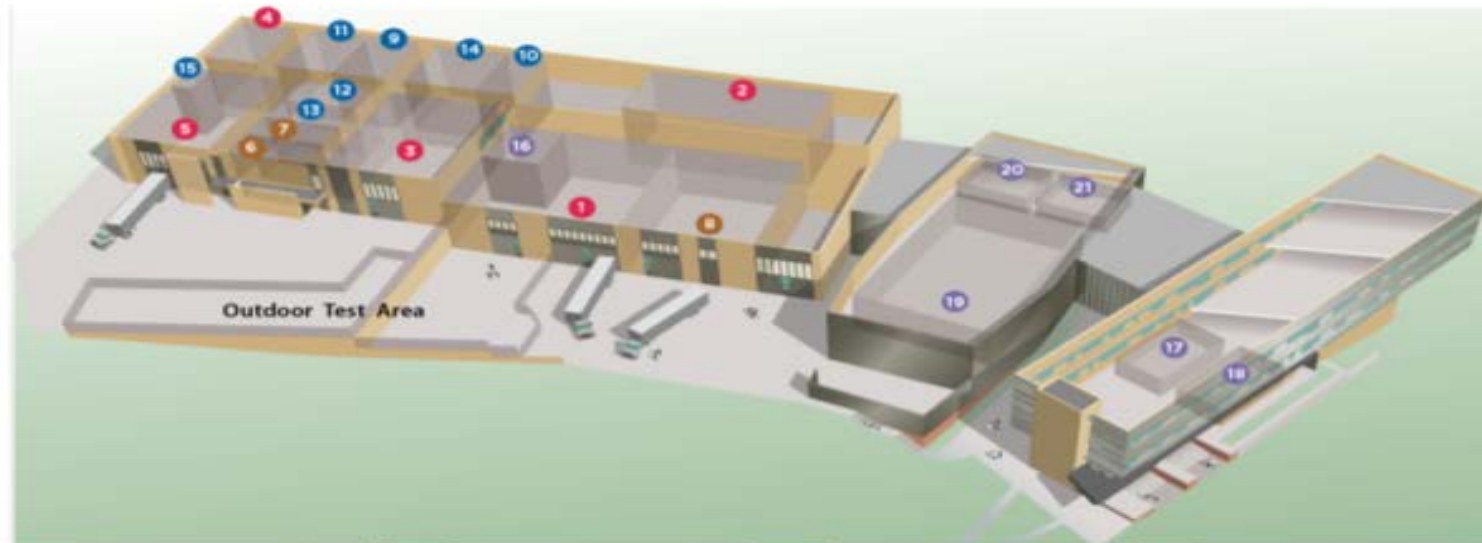

 Electricity Laboratories	 Thermal Laboratories	 Fuel Laboratories	 Data, Analysis, and Visualization
<ul style="list-style-type: none"> 1. 1 Power Systems Integration 2. 2 Smart Power 3. 3 Energy Storage 4. 4 Electrical Characterization 5. 5 Energy Systems Integration 	<ul style="list-style-type: none"> 6. 6 Thermal Systems 7. 7 Thermal Storage Materials 8. 8 Optical Characterization and Thermal Systems 	<ul style="list-style-type: none"> 9. 9 Energy Systems Fabrication 10. 10 Manufacturing 11. 11 Materials Characterization 12. 12 Electrochemical 13. 13 Energy Systems Sensor 14. 14 Fuel Cell Development 15. 15 High-Pressure Testing 	<ul style="list-style-type: none"> 16. 16 ESIF Control Room 17. 17 Visualization Room 18. 18 Secure Data Center 19. 19 High Performance Computing

 - Component Testing Laboratory Capability within ESIF

ESIF Component Test Utilization

Work Scope

	Energy Systems Integration Laboratory	Material Characterization Laboratory	Energy Systems Sensor Laboratory	High Pressure Testing Laboratory	Secure Data Center Technology Validation	High Performance Computing
4.1 Compressor Reliability	X	X		X		X
4.2. Materila of Construction in Hydrogen	X	X	X	X		
4.3.Hose Reliability	X	X	X	X	X	
4.4.Flow Meter Accuracy	X			X		
4.5.Low Temperature Sealing	X	X	X	X	X	
4.6.Technology Validation Study					X	X
4.7.Receptacle Wear and Nozzle Durability	X	X	X	X		
4.8.Temperature Activated Pressure Relief Device	X	X	X	X		
4.9. Certification & Listing of Components	X		X	X		
4.10.Localized Fire Scenarios	X	X				X
4.11.COPV Production and Reliability	X	X		X		X
4.12.Hydrogen Safety Sensor Performance	X	X	X	X		X

Component R&D Summary

- Work with codes and standards technical committees on revision efforts as these technical documents are vetted through early market system operation
- Identify root cause safety/reliability issues by utilizing statistical data provided through NREL Technology Validation
- Conduct component safety analysis and testing
- Develop user facility capabilities in new NREL ESIF building

ESIF - Energy Systems Integration Facility

New NREL laboratory facility, includes sensor lab, high pressure test lab, characterization lab, system integration lab, secure data room and high performance computing.



Summary

Relevance: Safe deployment of hydrogen fuel cell technologies is dependent on components that are proven to perform safely and reliably as measured against new safety and performance standards

Approach: NREL will work with manufacturers, installers and NREL's Technology Validation Program to prioritize gaps, then work toward closing those gaps by conducting hydrogen component R&D and performance validation.

Accomplishments & Progress: NREL's is leveraging component R&D accomplishments, having provided a sound technical basis for new hydrogen codes and standards and is now operating under a new MYPP to conduct root cause analysis and R&D testing to improve safety and reliability of hydrogen system components.

Collaborations: Collaboration with codes and standards technical committees, component manufacturers, industrial partners and hydrogen fuel cell applications experts has been a key part of NREL's success in advancing component program objectives

Proposed Future Work: NREL will continue to work with codes and standards technical committees to identify R&D gaps and to utilize the ESIF laboratory to conduct basic engineering R&D aimed at closing technology gaps.