

Hydrogen behavior and Quantitative Risk Assessment

PI: Katrina M. Groth

Team: Ethan Hecht, Chris LaFleur, Alice Muna, Isaac Ekoto, John Reynolds PM: Chris San Marchi

Sandia National Laboratories
Livermore, CA and Albuquerque, NM

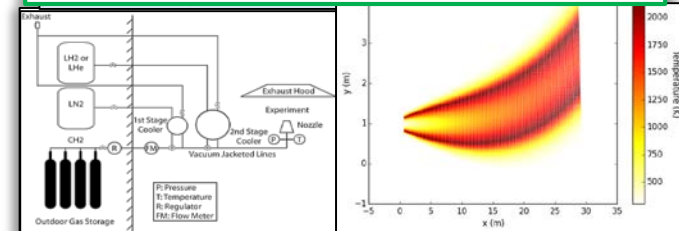
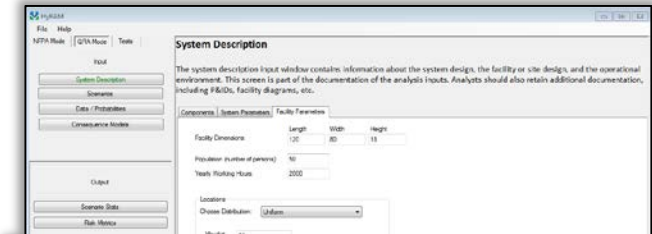

Project # SCS011

2015 DOE Hydrogen and Fuel Cells Annual Merit Review
June 9, 2015

This presentation does not contain any proprietary, confidential, or otherwise restricted information

Overview

Timeline

- Project start date: Oct. 2003
- Project end date: Sept. 2015*
- * Project continuation and direction determined by DOE annually.

Budget

- FY14 DOE Funding: \$1.0M
- Planned FY15 DOE Funding: \$1.2M
- Total DOE Project Value: \$22M

(Funding numbers include SCS#010, SCS#011 and SCS#025: Behavior, Risk and Infrastructure/Code program elements)

Barriers

- A. Safety Data and Information: Limited Access and Availability
- F. Enabling national and international markets requires consistent RCS
- G. Insufficient technical data to revise standards
- L. Usage and Access Restrictions – parking structures, tunnels and other usage areas

Partners

Industry & research collaborators:

Air Products and Chemicals Inc., HySafe, Linde, Tsinghua University,

SDO/CDO participation:

CGA, ISO TC197, NFPA2, CSA HGV4.9

International engagement:

HySafe, HyIndoor, IEA HIA Task 31



Relevance

Objective: Provide a **science & engineering** basis for assessing safety (risk) of H₂ systems and **facilitate use of that information** for revising RCS and permitting stations.

Barrier from 2013 SCS MYRDD	SNL Goal
A. Safety Data and Information: Limited Access and Availability	Develop & validate H ₂ behavior physics models to address targeted gaps in knowledge
F. Enabling national and international markets requires consistent RCS G. Insufficient technical data to revise standards	Build tools to enable industry-led C&S revision and safety analyses to be based on a strong science & engineering basis (physics and QRA).
L. Usage and Access Restrictions – parking structures, tunnels and other usage areas	Develop H ₂ -specific QRA [Quantitative Risk Assessment] tools & methods to support RCS decisions and to enable Performance Based Design (PBD) code-compliance option.

Relevance: SNL work brings science, rigor, into decision-making

- **Successful application of QRA & behavior models in H₂ RCS:**
 - Established GH₂ separation distances (NFPA2 Ch. 7): SAND2014-3416
 - Calculated risk from indoor fueling (NFPA2 Ch. 10) and identified ambiguity in NFPA2 Ch. 10 requirements: SAND2012-10150
- **Current SNL RCS activities** (see SCS-025 presentation)
 - Enabling *Performance-based* compliance option (NFPA2 Ch. 5)
 - Developing generalized approach for defining station-specific mitigations (e.g., safety distances) for ISO TC197
 - Revision of LH₂ separation distances (NFPA LH2 subcommittee)
- **Future areas of application of the work:**
 - Enclosures (NFPA2 Ch7 and ISO TC197)
 - Evacuation zone analyses
 - Design insight: what is the safety impact of different designs? which components drive risk/reliability (and which ones don't)?

SNL Hydrogen Safety Program Approach

The Safety, Codes and Standards program coordinates critical stakeholders and research to remove technology deployment barriers

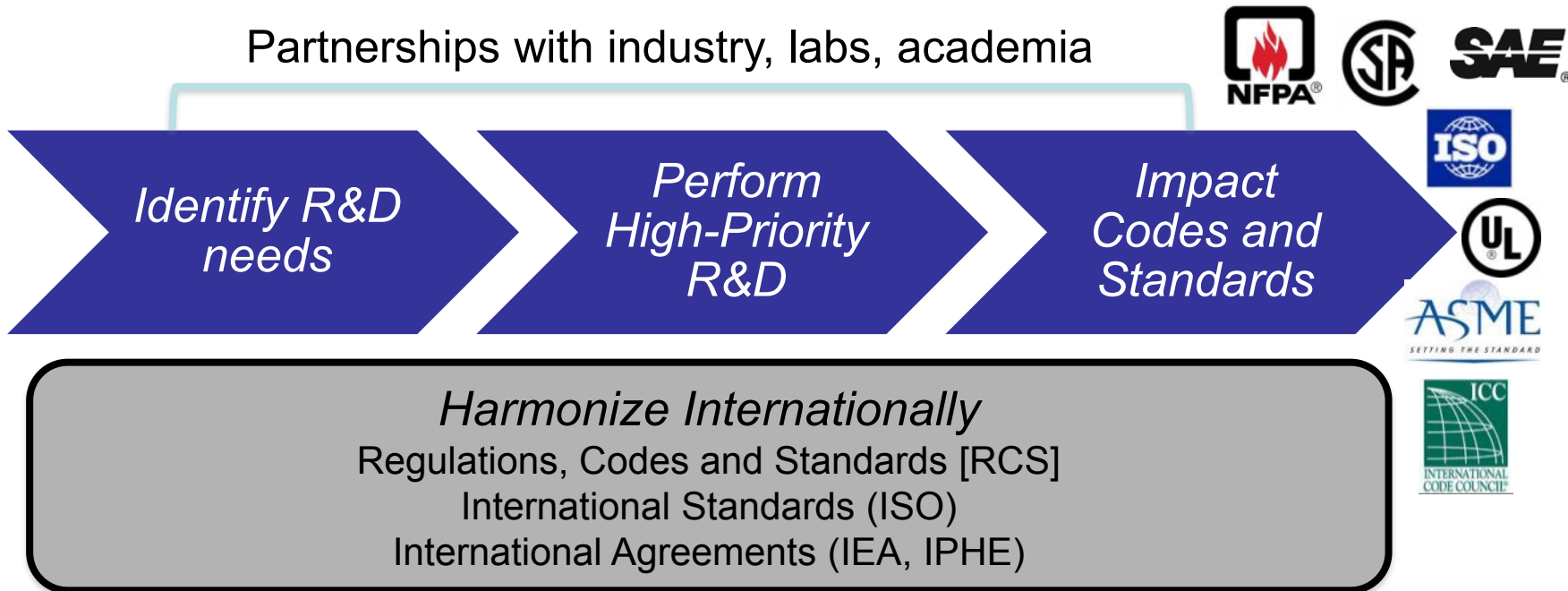

Project Approach: Three coordinated activities

Apply R&D in RCS



Apply risk assessment techniques in step-out hydrogen technologies

QRA methods, tools R&D

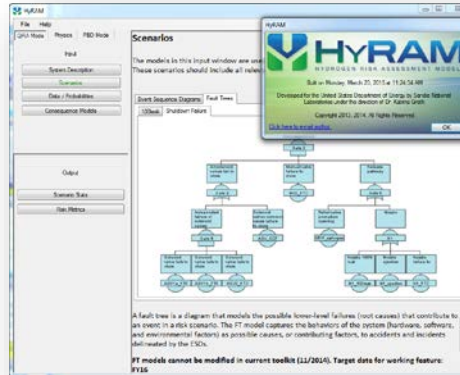

Develop integrated algorithms for conducting QRA (Quantitative Risk Assessment) for H₂ facilities and vehicles

H2 behavior R&D

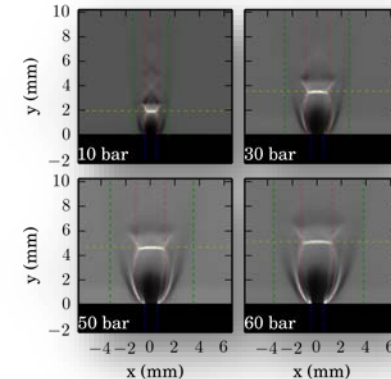

Develop and validate scientific models to accurately predict hazards and harm from liquid releases, flames, etc.

Enabling methods, data, tools for H₂ safety & RCS community

QRA and behavior R&D provides a means for bringing science into the development and revision of codes & standards.

Approach / FY14-15 Milestones

Hydrogen Behavior	Completion date or status
<ul style="list-style-type: none"> • Design and construct laboratory for Cold H₂ release experiments 	
<ul style="list-style-type: none"> • CRADA w/Linde on design • Heat exchanger, plumbing, and nozzle design • Safety reviews and approvals • Laboratory design report 	<p>Aug 2015 Ongoing (75%) Ongoing (75%) Ongoing (75%)</p>
<ul style="list-style-type: none"> • Experimentally validate equivalent source model for high pressure H₂ 	
<ul style="list-style-type: none"> • Collection of data (schlieren and Rayleigh scattering images) • Data analysis, model development and validation 	<p>Jan 2015 March 2015</p>
<h2>Quantitative Risk Assessment</h2>	
<ul style="list-style-type: none"> • Develop the HyRAM toolkit/platform to facilitate use of hydrogen safety research in industry-led safety analyses 	
<ul style="list-style-type: none"> • Complete HyRAM prototype v1.0 (w/GH2 release and jet flame models) • Develop & integrated HyRAM module for curved flame model • Develop & integrate HyRAM module for overpressure model 	<p>Sept 2014 Nov 2014 June 2015 (50%)</p>
<ul style="list-style-type: none"> • Initiate HyRAM testing & documentation 	
<ul style="list-style-type: none"> • Complete copyright assertion • Identify & contact alpha testers from range of stakeholders • Release HyRAM version 1.0 to alpha test group • Develop documentation structure, initial algorithm and user guides. 	<p>Jan 2015 Feb 2015 Ongoing (7 of 22 invitees) Sept 2015 (40%)</p>

Accomplishment: HyRAM toolkit

- Released prototype HyRAM v1.0
 - First-of-its-kind software tool
 - End-to-end quantitative risk assessment
 - integrated system and component data (e.g. reliability, failure models)
 - coupled to engineering models (e.g. gas dispersion, heat-flux)
 - outputs risk metrics (PLL, FAR, AIR)
 - Stand-alone physics mode
 - e.g. heat flux from curved flame model developed and experimentally validated by SNL in FY12
- Ongoing development activities to enhance toolkit
 - User generated scenarios
 - Overpressure model (developed and experimentally validated by SNL in FY13)
 - System definition and behavior models in 3-dimensions

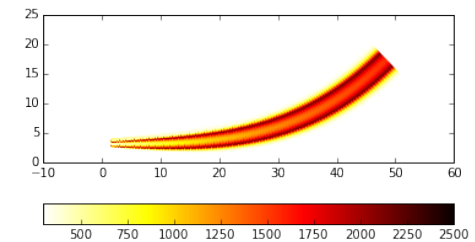
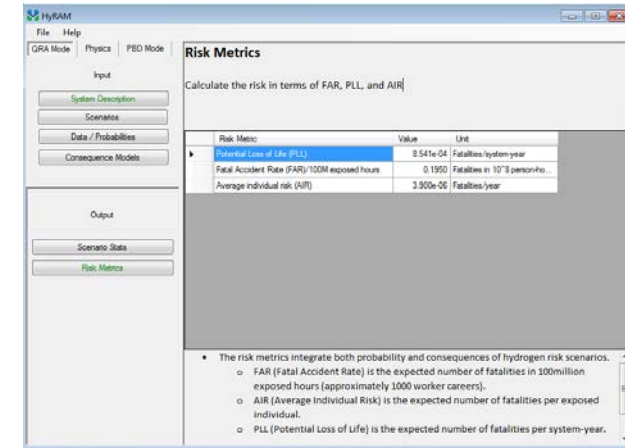

Robust, consistent foundation for developing & complying with codes and standards

- enables industry-lead analysis (instead of SNL lead)
- traceable, documented basis
- enables system-specific Performance-Based Approach to compliance, development of codes (see Thursday's presentation)

Example HyRAM calculation: Full QRA

Allows credit for mitigations that reduce likelihood of events & provides system-specific risk-reduction insight

Input

- System description (components, parameters, facility description)

The screenshot shows the HyRAM software interface with several input tables:

- System Parameters - Piping:**

Variable	Value	Unit
Pipe Outer Diameter	0.375	Inch
Pipe Wall Thickness	0.065	Inch
- System Parameters - Components:**

Component	Count	Unit
# Compressors	0	...
# Cylinders	0	...
# Valves	5	...
# Instruments	3	...
# Joints	35	...
# Hoses	1	...
- Facility Parameters - Occupants:**

Variable	Value
Population (Number of persons)	50
Working hours per year	2000

Output

- Total system risk
 - Enables comparisons, e.g. risk **with** vs. **without** gas detection

Risk Metric	Value	Unit
Potential Loss of Life (PLL)	4.500e-04	Fatalities/system-year
Fatal Accident Rate (FAR)/100M exposed hours	0.1027	Fatalities in 10 ⁸ person-ho...
Average individual risk (AIR)	2.055e-06	Fatalities/year

Risk Metric	Value	Unit
Potential Loss of Life (PLL)	5.000e-04	Fatalities/system-year
Fatal Accident Rate (FAR)/100M exposed hours	0.1141	Fatalities in 10 ⁸ person-ho...
Average individual risk (AIR)	2.283e-06	Fatalities/year

- Insight into risk drivers: scenario frequency & risk ranking

Scenario	End State Type	Avg. Events/Year	PLL Contribution
0.01pct Release	No Ignition	0.03448206	0.00%
0.1pct Release	No Ignition	0.00495318	0.00%
1pct Release	No Ignition	0.00148741	0.00%
10pct Release	No Ignition	0.00116683	0.00%
100pct Release	No Ignition	0.00071471	0.00%
0.01pct Release	Jet fire	0.00025097	0.00%
0.01pct Release	Explosion	0.00012448	0.01%
100pct Release	Jet fire	0.00003669	0.00%
0.1pct Release	Jet fire	0.00003605	0.00%
0.1pct Release	Explosion	0.00001788	0.00%
100pct Release	Explosion	0.00001770	95.15%
1pct Release	Jet fire	0.00001083	0.00%
10pct Release	Jet fire	0.00000849	0.00%
1pct Release	Explosion	0.00000537	0.03%
10pct Release	Explosion	0.00000421	4.81%

Accomplishment: HyRAM alpha testing with industry

- Initiated user-testing activities on HyRAM v1.0alpha
 - Stakeholders in various aspects of H₂ safety community identified
 - R&D
 - government
 - industry
 - target : 40 users
 - (As of March 2015) HyRAM being used by 7 stakeholder groups (up to 2 alpha users per group)

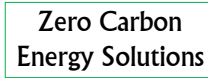

- Have also contacted additional 15 stakeholder groups– we are at various stages of the license process with those groups
 - Allowing them to explore the power of HyRAM & provide feedback on prototype

User feedback is crucial to ensure creation of **enabling** tools & guidance

User testing causes early engagement and sparks interest from stakeholders

Accomplishment: Validated equivalent source model

- Created model to give boundary conditions to reduced-order integral model from high-pressure choked flows
 - Validated up to 60 bar, **using hydrogen**
 - Collaboration with visiting researcher from Tsinghua University
- Scaling laws relate known parameters (P_0 , P_{atm}) to boundary conditions (S_0 , d_{eff} , $\rho_{cl,0}$)
- Conserves mass, momentum, energy, while allowing air entrainment in shock region

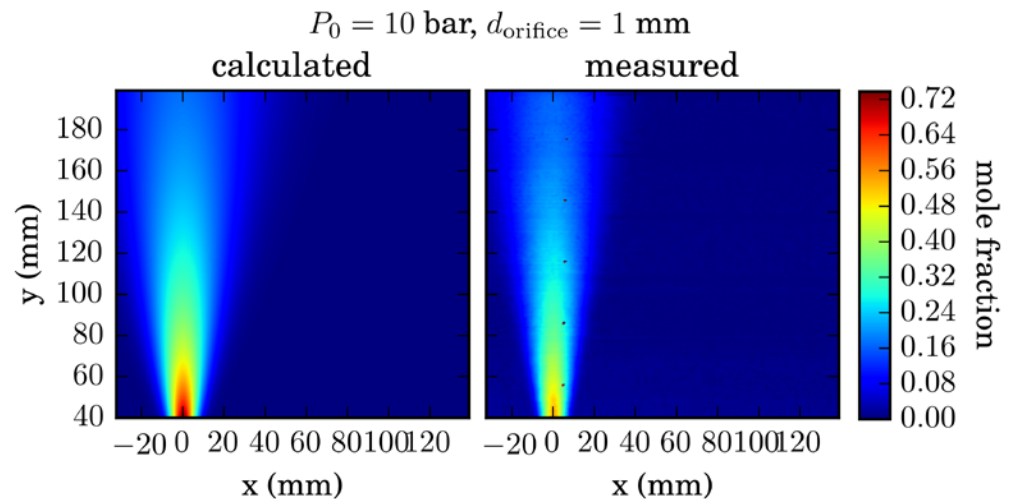

Enables fast and accurate modeling of concentration field and flammability envelopes for high-pressure releases in *any* orientation; can be implemented in QRA to predict hazard boundaries in 3-dimensions

Accomplishment: Cold Hydrogen Release Laboratory

- Goal: Build laboratory that can be used to develop validated model needed for QRA of release from cryogenic storage
 - Well controlled boundary conditions and accurate diagnostics necessary for proper model validation
- Components being fabricated and assembled
- Expected trials by then end of FY15

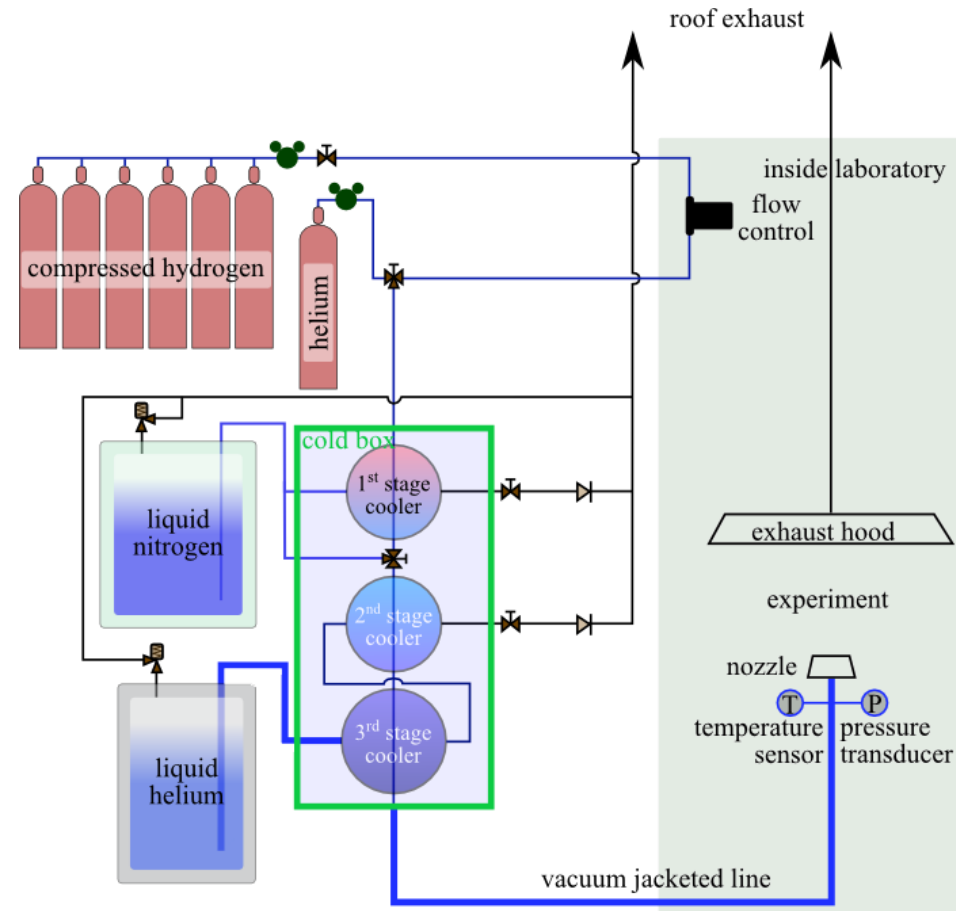

Lack of validated models is a key barrier to QRA for liquid H₂ systems. Data will enable risk informed separation distance codes and standards modifications and QRA guided designs

Collaborations

Partner	FY 14 - FY15 Role
Linde (Hayward, CA) Nitin Natesan, Mike Ciotti, Jennifer Yan	Signed CRADA - In-kind support, data exchange for QRA tool and QRA demonstration activities, LH2 laboratory
HySafe (International) Andrei Tchouvelev	Technical exchanges, workshop hosting, parallel/complementary development of QRA toolkits
Tsinghua University (China) David Christopher, Xuefang Li	Visiting researcher at SNL helped develop validated equivalent source model for high-pressure H ₂
NREL, PNNL, ITM Power (UK), ZCES, GWS Solutions, T&A (Canada), Proton OnSite	Signed NDAs - User feedback and testing on for HyRAM v1.0alpha

SDO/CDO memberships
NFPA 2 ICC
ISO TC 197 WG24
CGA
CSA HGV4.9

Organization memberships*
HySafe
IEA HIA Task 31 H2USA Locations WG H2USA Stations WG
DOE CSTT

Technical exchanges, presentations & discussions
CaCFP, ASME
DOE Hydrogen Safety Panel, DOT FRA
PNNL, NREL
AIST (Japan), HyIndoor (EU)

* Participation with these research initiatives enables sustained technical exchanges with Air Liquide, HSL (UK), Joint Research Centre (NL); KIT (DE), UQTR (CA), Univ. of Ulster (IE), BMW, Toyota, and others

Remaining challenges & barriers

- **Hydrogen Behavior**

- Address missing/unvalidated behavior models -- provides ability to overcome station-siting barriers (barriers A, G, L)
 - cold/cryogenic H₂ release behavior
 - flow/flame surface interactions
 - physical model based ignition probability

- **QRA/ HyRAM**

- Add features to current prototype - provides ability to get system-specific insights into safety drivers (barriers G, F)
 - Lack of interfaces for safety/reliability modeling (e.g., Fault Tree and Event Sequence Diagram, importance analysis, uncertainty features)
 - Reframe HyRAM software to enable 3-dimensional modeling capability
 - Impingement and asphyxiation models
- Transition HyRAM beyond prototype (e.g., formal software development activities, software quality assurance)

Red boxes denote Sandia FY15/16 priorities

Technology transfer activities

- CRADA with Linde supporting R&D activities signed Aug 2104
- Pursuing CRADA with industrial gas suppliers via third party organization
- HyRAM v1.0alpha copyright obtained Jan 2015.
 - The current release is for demo and testing; therefore the release is being controlled to known and trusted collaborators
 - The long-term vision is that either:
 - (1) we make available an unsupported version of the HyRAM tool package, or
 - (2) find an entity to support the software via exclusive license
 - Plan to be developed after additional prototyping & user engagement activities in FY16
 - The HyRAM framework is being structured to be freeware (at least initially) and as flexible as possible for future decisions on “openness”

Proposed future work

- Rest of FY15:
 - **HyRAM**: Integration of overpressure model into QRA mode; alpha user testing via main partners
 - **Behavior**: Develop experimental capability for liquid/cryogenic H₂ behavior (w/ financial support of industrial stakeholders)
- FY16:
 - **HyRAM**: Add risk-features (Fault Trees); Increase spatial fidelity of HyRAM (from 1-D flames to 2-D and 3-D); expand scope of testing activities
 - **Behavior**: Conduct liquid/cryogenic H₂ release experiments and develop validated LH₂ release model
- Out-years
 - Highly accessible (web-based/app) tool for enabling end-users to implement these algorithms
 - Continue experimental work to generate needed validation data and develop necessary science-based models (e.g. wall interactions)

Response to last year's Reviewer's comments

- AMR2014 comment: *“Based on input/questions at the merit review, there appears to be room to expand literature research and verify whether previous research has covered some of the topics under investigation in this project/program..”*
 - Some questions were outside the area of expertise of the presenter (but not the group). The necessary level of detail cannot be captured during a short AMR presentation. Sandia's publications provide details and references to relevant literature.
- AMR2014 comment: *“It is unclear how benchmarking from Sandia National Laboratories (SNL) leads to an 18% increase in station readiness. It is not certain that there are code officials who agree with this number, nor is it clear how the QRA information is currently being used/applied to safety, codes and standards (SCS).”*
 - Added slide 5 to show how SNL QRA work was used to develop multiple aspects of NFPA 2 (e.g., separation distances for gaseous storage, indoor fueling requirements, performance-based requirements); Ongoing work is focusing on LH2 storage. QRA has also been adopted as part of development process within ISO TC-197.
 - The 18% figure refers to the number of potential H₂-sites in CA which could house a hydrogen station based on NFPA2 separation distances generated by SNL using QRA. Prior to those NFPA2 revisions, 0% of potential sites met separation distance criteria. After revisions, 18% of sites could house hydrogen. Ongoing work will continue to improve this metric.
- AMR2014 comment: *“Collaboration with U.S. entities seems to be purpose-oriented and effective. The scope, intensity, and impact of collaboration with non-U.S. partners cannot be judged on the basis of the information provided.” (Two comments to the effect that scope of collaborations are unclear)*
 - The description of collaboration activity was enhanced – see 2015 version of “Collaborators” slide
- AMR2014 comment: *“The work absolutely has the potential to affect code in a positive way (reducing quantity-distance restrictions, thus making fueling stations fit better in current footprints). The largest hurdle is going to be getting code officials to understand this QRA approach and to adopt it. The current project does not have a planned goal for this, however.”*
 - Engaging with code officials is critical, and SNL is pursuing multiple avenues for doing this; these activities are presented in a separate AMR presentation- **See Thursday presentation by LaFleur.**
- AMR2014 comment: *“An explanation is lacking on how data from (validated) behavioral and consequence modeling are actually transferred to the QRA module, realizing that the model outcomes are affected by assumptions for initial and boundary conditions that may quite well differ from those in the actual case considered.”*
 - Documentation is an integral part of HyRAM development. Both a user guide and an algorithm guide will be released with the software to assure proper use and document all assumptions in the models and how they are implemented
- AMR2014 comment: *“The project has a solid science-based approach towards the establishment of a powerful tool for facilitating (1) improvement of RCS and (2) PBD. This avoids subjectivity in the assessment and contributes to enhanced confidence of AHJs in the application of this approach, which will in turn promote deployment of hydrogen systems.”*
 - **We are continuing this approach in FY15...**

Summary

- **Three-pronged R&D approach:** two R&D activities (SCS011) feeding C&S development (see LaFleur presentation on Thursday)
 - Develop user-friendly tools to enable industry-led analyses w/state-of-the-art hydrogen models
 - Fill in gaps in scientific understanding and data relevant to LH2 releases
- **Reducing barriers related to lack of technical data for RCS revision**
- **Technical Accomplishments:** HyRAM Toolkit alpha version released for user testing, Overpressure and curved flame physics models added, Validated source model for choked flow in any orientation, and completed design of cold plume release lab modifications.
- **Future Work:** Extend implementation of PBD-compliance option; Increase accessibility of HyRAM; Validate cold plume release model and develop necessary science-based models to more fully characterize hydrogen release and interaction behaviors (e.g. impingement, wall interactions)

Technical Back-Up Slides

Continuing to extend the state-of-the-art

Objective: Integrate the best science & engineering models into a comprehensive platform which facilitates evidence-based safety decisions.

QRA method, data & models

- Hazards
- Accident sequences
- Release frequencies
- Ignition probabilities
- Harm/damage

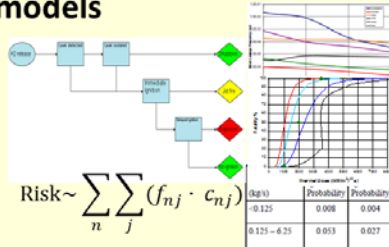

Reduced order physical consequence models

- GH2 release
- Ignition
- Reduced-order jet flame models
- Deflagration overpressure

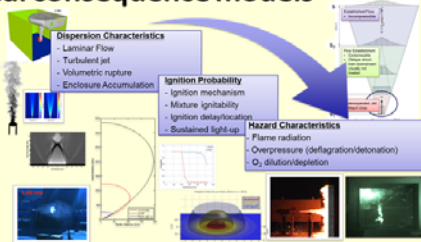

Outstanding gaps: System operating experience; component failure rates; Models for LH2 releases & cold gas plumes; ignition / flame light-up; Effect of barriers, detectors;

Integrated HyRAM toolkit

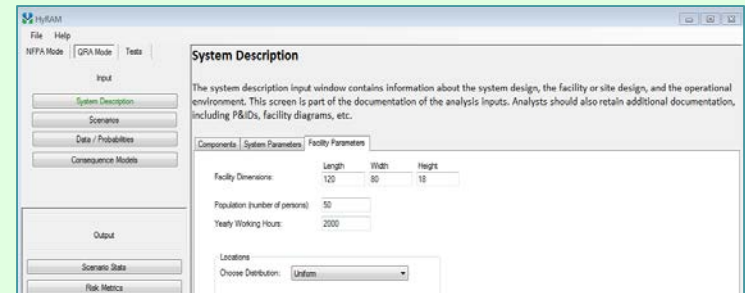

Validated Physical models for: Overpressure, LH2 release,

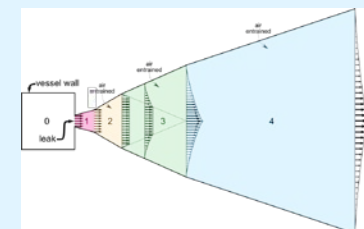
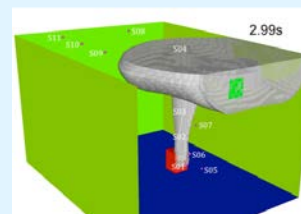

HyRAM Modules: Cause & harm models

Accident sequences

- Hazards considered: Thermal effects (jet fire), overpressure (explosion/deflagration)

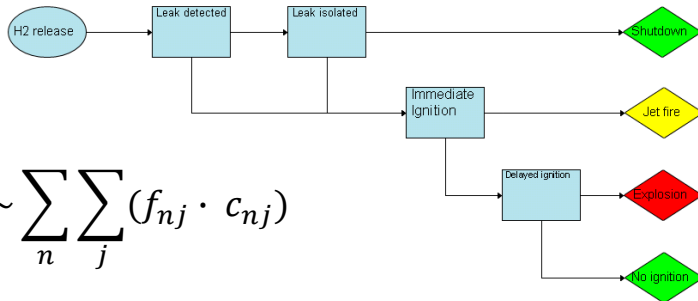

$$\text{Risk} \sim \sum_n \sum_j (f_{nj} \cdot c_{nj})$$

$$f(\text{JetFire}) = f(\text{H2release}) * (1 - \text{Pr}(\text{Detect})) * \text{Pr}(\text{IgnImmed})$$

Release frequency

- Expected annual leak freq. for each component type -- Data developed from limited H₂ data combined w/ data from other industries.

$$f(\text{H2release}) = \sum_{i=9 \text{ comps}} n_i * E(f(\text{Leak}_i)) + E(\text{Pr}(\text{accidents})) * n_{\text{demands}}$$

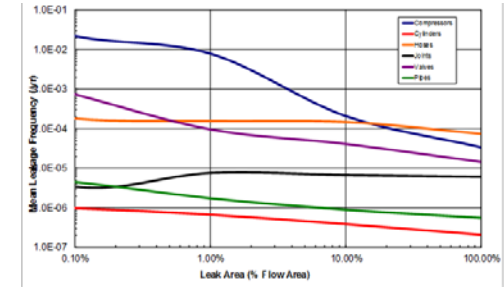

Ignition probability

- Extrapolated from methane ignition probabilities
- Flow rate calculated using *Release Characteristics* module

Hydrogen Release Rate (kg/s)	Immediate Ignition Probability	Delayed Ignition Probability
<0.125	0.008	0.004
0.125 – 6.25	0.053	0.027
>6.25	0.23	0.12

Harm models

- Probability of fatality from exposure to heat flux and overpressures – multiple options

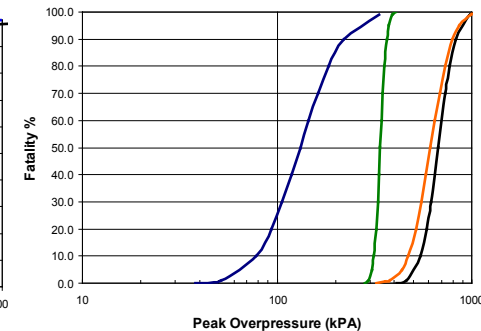
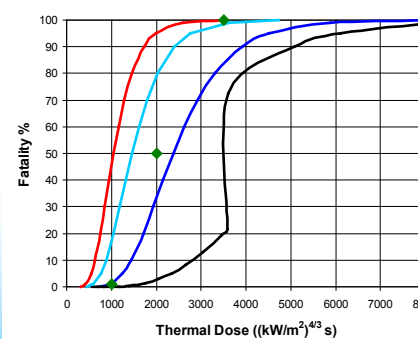

HyRAM Modules: Behavior & Consequence models

Release Characteristics

- H₂ jet integral model developed & validated
- Source models developed for LH2 & choked flow inputs

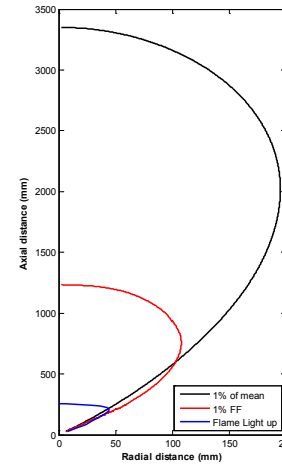
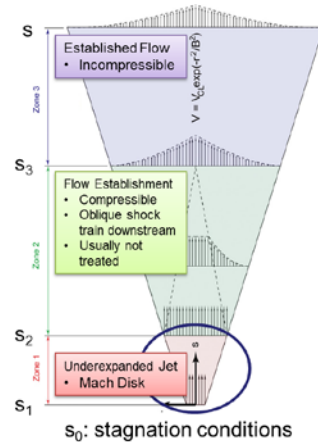

Ignition/Flame Light-up *(pending addition)*

- Flammability Factor verified for ignition prediction
- Light-up boundaries identified
- Next: sustained flame prediction

Flame Radiation

- Flame integral model developed
- Multi-source models significantly improve heat flux prediction
- Surface reflection can be a major potential heat flux contributor

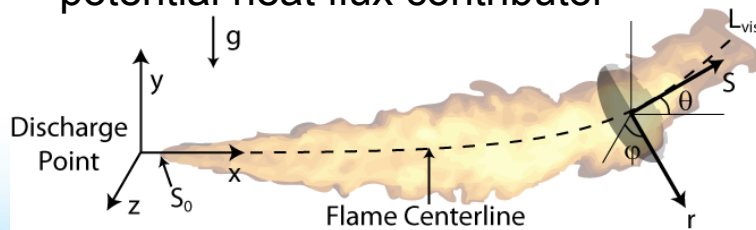

Deflagration within Enclosures

- Ventilated deflagration overpressure explored experimentally and computationally
- Current QRA module requires CFD results.
- Engineering model framework pending

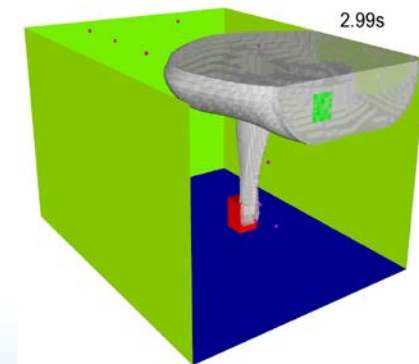

Example HyRAM calculation: Jet Flame physics

Consequence-only modeling

Input

- Leak size and known conditions.

Input		Output	
Notional Nozzle Model: <input type="text" value="Birch2"/>			
Plot routine			
<input checked="" type="radio"/> PlotT <input type="radio"/> PlotIso			
Variable	Value	Unit	
Ambient Temperature	15	Celsius	▼
Ambient Pressure	1	Atm	▼
Hydrogen Temperature	15	Celsius	▼
Hydrogen Pressure	10000	PSI	▼
Leak Diameter	0.01	Meter	▼
▶ Relative Humidity	0.89	...	
Leak Height from Floor (y0)	1	Meter	▼

Output

- Shows flame temperature at different distances -- direct analog to original safety distance work.

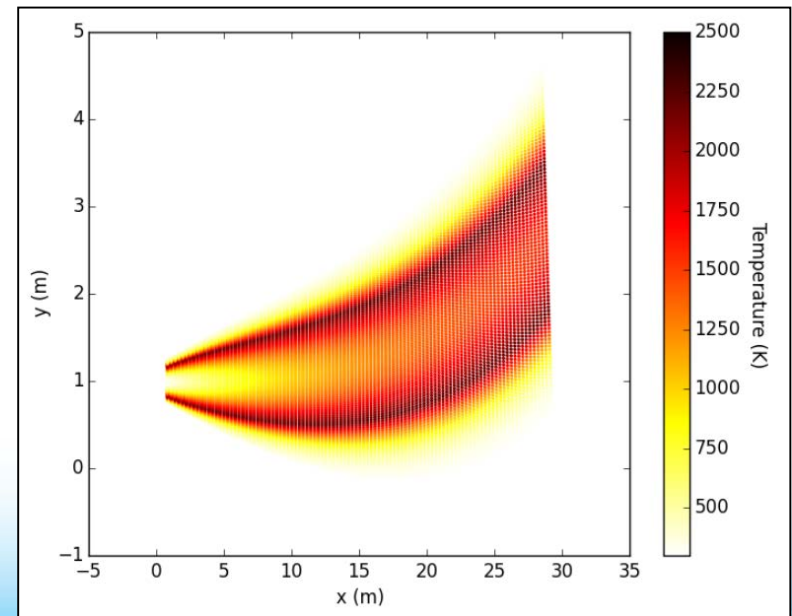

HyRAM software architecture

