

# Continuous Fiber Composite Electrofusion Coupler

**David Hauber** – P.I.    **Brett Kimball** - Presenter

Automated Dynamics, Part of Trelleborg Group  
June 14, 2018

# Overview

## ■ Timeline and Budget

- Project Start Date: 12/1/15
- Project End Date: 4/1/19
- Total Project Budget: \$1,876,865
  - Total Recipient Share: \$376,865
  - Total Federal Share: \$1,500,000
  - SRNL Share: \$525,000
  - Total DOE Funds Spent\*: \$885,369
    - \*As of 03/31/2018

## ■ Barriers addressed

- D: High As-Installed Cost of Pipelines

## ■ Partners

- DOE: Project Sponsor
- SRNL: Project Partner
- NOV: Project Partner
- Automated Dynamics, part of Trelleborg Group: Project Lead

### Technical Targets

Transmission Pressure (bar)	100
H <sub>2</sub> Leakage	< 5x10e-4 cm <sup>3</sup> H <sub>2</sub> /s
Lifetime (years)	50

# Relevance

- **3-Year Project Objective:** Design and Validate pipe coupler for FRP Hydrogen Delivery for yet to be installed pipes, without use of elastomeric seals

ASME B31.12 Code Committee (Hydrogen Piping and Pipelines) concerned that existing seal [PROBLEM THAT NEEDS IMPROVEMENT ON NEXT DESIGN] components (i.e. o-rings or other elastomeric seals) will require maintenance in underground service.

- 350bar Burst, <0.5% flow leak rate, 50 year life
- **Current Year Objective, April 2017 – April 2018**
  - Pass Milestone for Fatigue Failure Criteria (fail pipe before coupler)
- **Past Year's Impact**
  - Advanced Technology to allow low-maintenance composite H<sub>2</sub> pipelines.

# Approach

## Enable FRP for Hydrogen Delivery

- Problem with existing steel pipe solution is corrosion
- Problem with existing o-ring based seals on FRP is o-ring maintenance
- **Develop Pipe Coupling Technology through unique combination of existing market solutions**
  - Metal end fittings for FRP ~~with o-rings~~
  - Electrofusion Couplers for ~~low-pressure~~ pipe
  - Thermoset FRP with HDPE liner
- Non-standard pipe for EF requires custom EF couplers
- Builds from past DOE funded Project to Savannah River National Lab, 2013

Go/No-Go Criteria 2017	Result 2017
Leak Rate < $5 \times 10^{-4}$ cm <sup>3</sup> He/s	<b>PASSED:</b> $10 \times 10^{-6}$ cm <sup>3</sup> He/s
Burst Pressure > 350bar	<b>PASSED:</b>
Fatigue: Pipe bursts before coupler bursts	Not Passed, revisiting in 2018

# Approach

## Milestones and Percent Completion

<b>Go/No-Go (Dec 2017)</b>	<b>12/31/17</b>	<b>Prototype must show 1) leakage rate less than <math>5 \times 10^{-4}</math> cm<sup>3</sup> He/s, 2) hydrostatic standards set by ASTM D2992 at 1,500psi (~100bar), an R ratio of 0.1 and pipe must burst before joint bursts.</b>	<b>Fatigue Criteria Not Yet Complete (50%)</b>
<b>Interim Design Review</b>	<b>3/31/18</b>	Continue Manufacturing Prototypes and Conduct Interim design review	50%
<b>Conduct Fatigue Test</b>	<b>6/30/18</b>	Test Coupler by hydrostatic standards set by ASTM D2992 at 1,500psi (~100bar), an R ratio of 0.1. Pipe must burst before joint bursts.	50%
<b>Fatigue to Failure, Burst, Leak, Tests</b>	<b>9/30/18</b>	Fatigue test at R=0.1, 1,500psi, run on coupler and pipe. Pipe must fail before coupler. Burst Test must pass 350bar (5,076psi). Leakage rate less than $5 \times 10^{-4}$ cm <sup>3</sup> H <sub>2</sub> /s,	50%
<b>Create Manufacturing and Quality Plan</b>	<b>9/30/18</b>	Complete Manufacturing and Quality Plan.	50%
<b>Final Design Report</b>	<b>12/30/18</b>	Write final report	25%

# Accomplishments: Redesign Underway

- Fundamental Problem
  - Weakening of small amount of plastic acting as leak barrier, during fatigue test.
- Solution
  - Increase volume (cylinder thickness) of plastic acting as sealing mechanism.
  - Increase redundant sealing area.
  - Remove non-essential materials from design that cause potential failures.

# Accomplishments: Redesign Underway

- **Previous design did not pass fatigue test**
  - 2 Bond Areas: outside and inside of wire
  - Leak path through porous media
  - Crack in centerline allows leak path potential through porous media
- **New Design**
  - 1 Bond Area: Centerline may crack; monolithic plastic is redundant sealing mechanism



# Accomplishments: Redesign Underway



Previous Design	Current Design	Improvements
2 bond zones	1 bond zone	<ul style="list-style-type: none"> <li>• ½ the area for potential leaks</li> <li>• ½ the area to need heat transfer</li> </ul>
4 materials: Pipe Liner, Metal Wire, <b>wire coating</b> , outer plastic	3 materials: Pipe Liner, Wire, Outer Plastic	<ul style="list-style-type: none"> <li>• No need for intermediate layers (wire coating above and below wire) to bond</li> <li>• More consistent through fewer manufacturing steps</li> <li>• Fewer voids due to fewer dissimilar material joining</li> </ul>
“Thick” bond zone: Wire Ø+ 2x PE Coating thickness	“Thinner” bond zone: Wire Ø only	<ul style="list-style-type: none"> <li>• Less shear strain</li> <li>• Less thru-thickness variation</li> </ul>



# Accomplishments: Redesign Sealing Mechanism

Previous Design

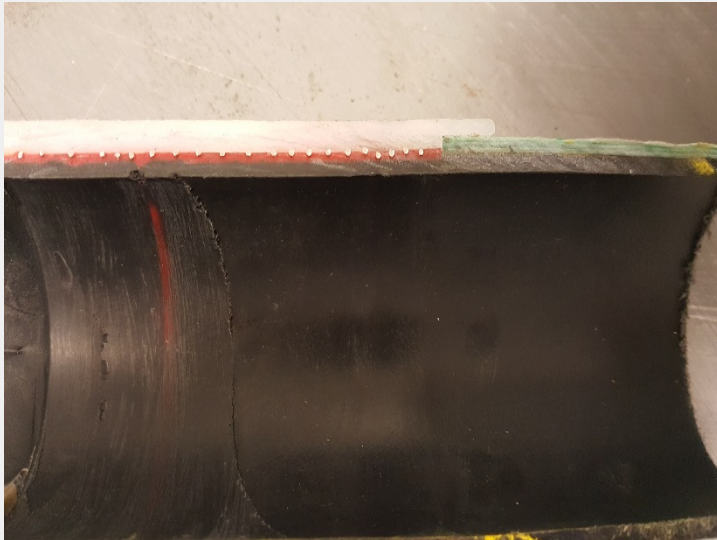

Current Design

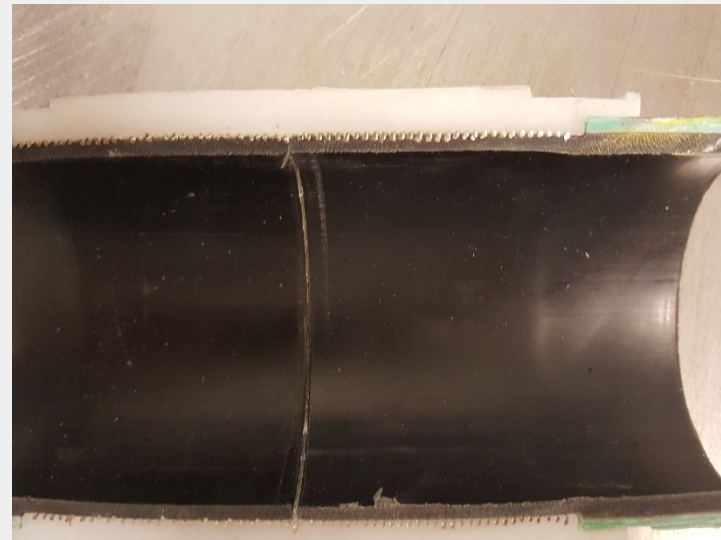

# Accomplishments: O-Ring Based Design for Reference

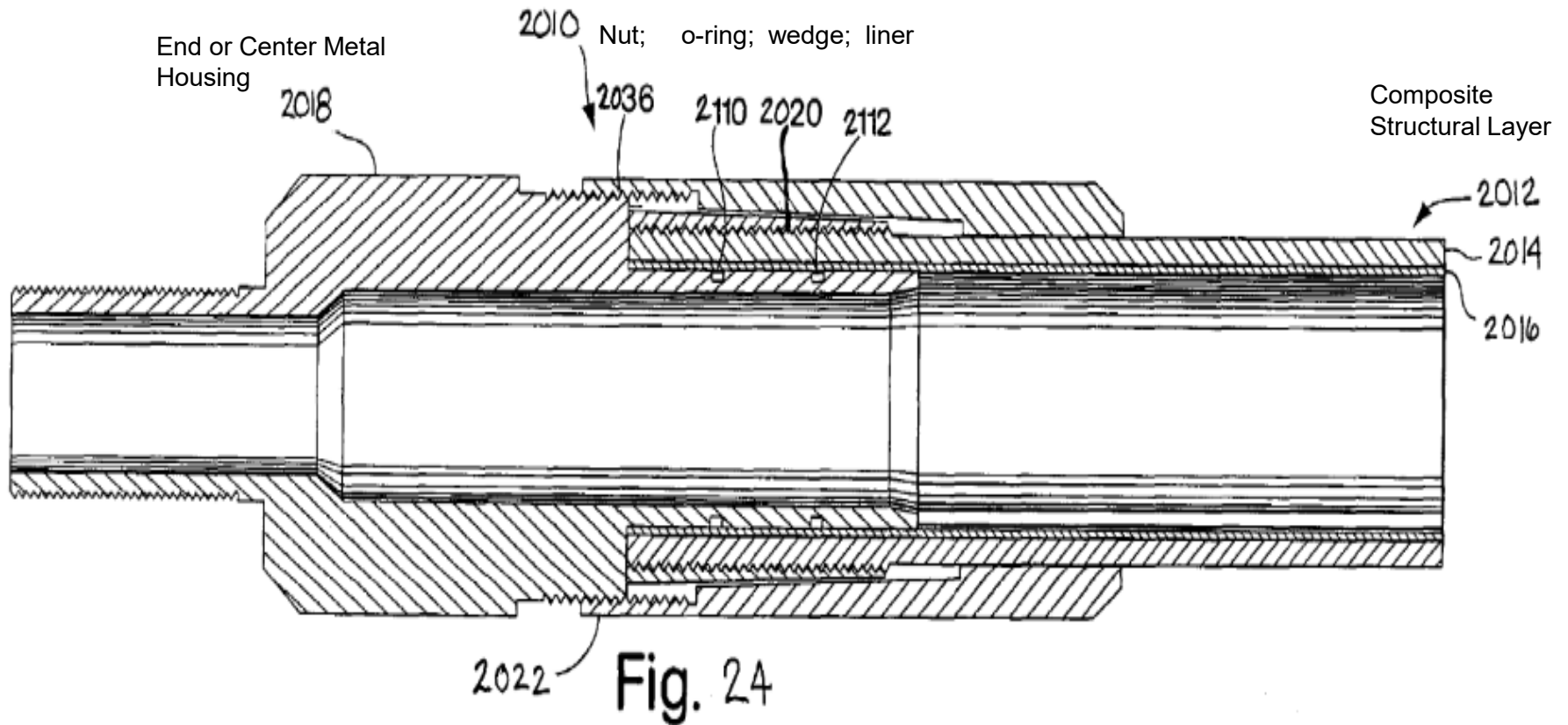

# Accomplishments: New Design

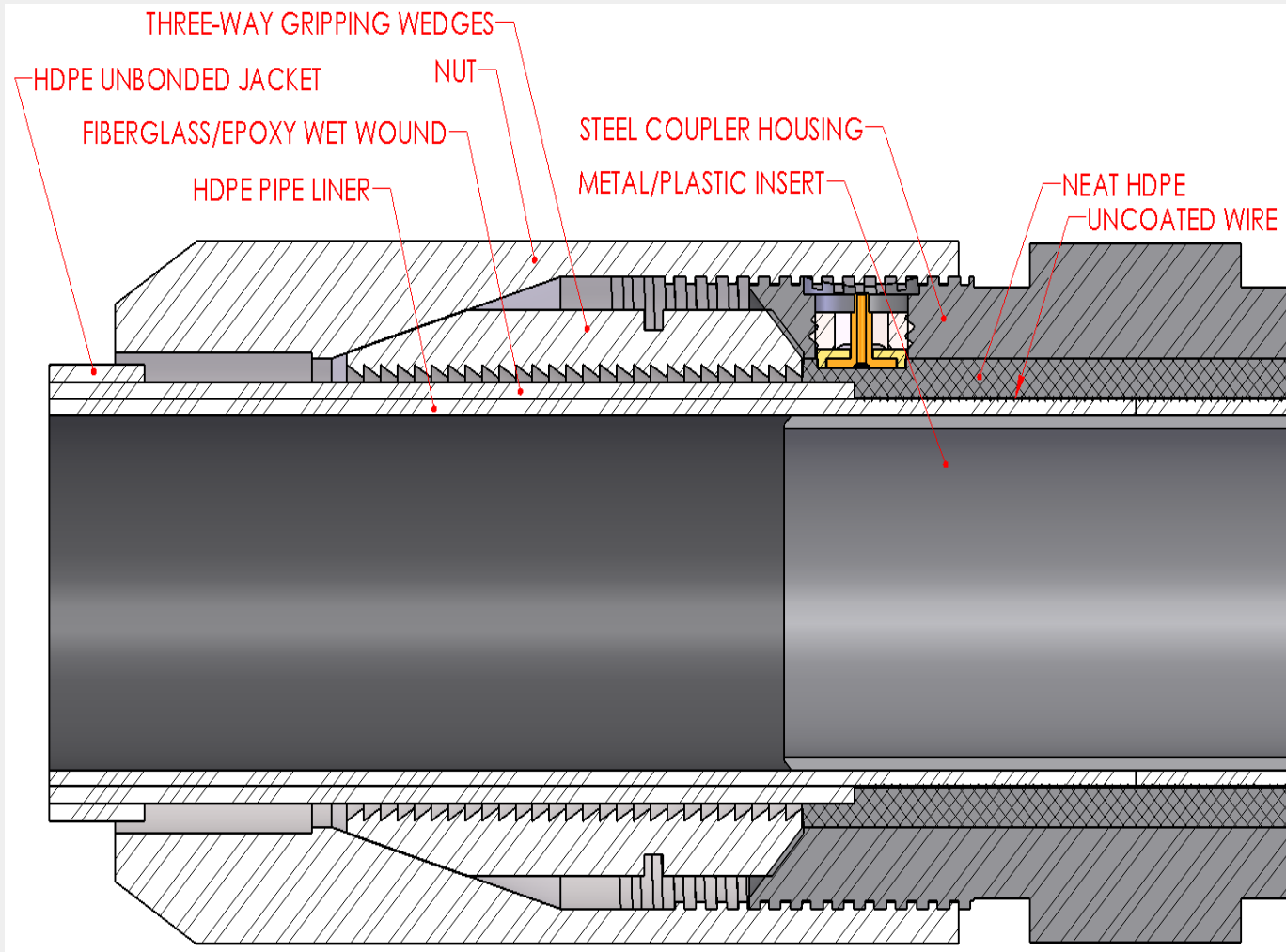

# Progress: Response to last year's comments

- **How does this address previously installed pipe?**
  - The goal of this project is for future pipe installs. But for already installed pipe, each coupler is cut out and a section with two EF couplers is installed.
- **How does this work in the field? Not at all clear how coupler will be installed.**
  - In field, pipe is cut and machined with automated equipment designed specifically for this. This is well established technology. Install coupler components on each end of pipe; join; electrofuse; assemble mechanical components; wait to cool; finish.
- **How can you prove 50 year lifespan?**
  - Fatigue stress values correlate with # of cycles (Life prediction)



Credit: NOV





Credit: H&S Tools

# Progress: Testing

## Fatigue Test

- ASTM D2992
- Prototype Fatigue Criteria:  $< 5 \times 10^{-4} \text{ cm}^3 \text{ He/s}$
- Fatigue to Failure Criteria:  $< 5 \times 10^{-4} \text{ cm}^3 \text{ H}_2/\text{s}$
- Room Temperature
- Min/Max pressure 150 / 1,500psi (R Value = 0.1)
- Varying R and testing produces fatigue data for extrapolation info Millions+ cycles

# Collaborations

 <p><b>SRNL</b><sup>TM</sup> SAVANNAH RIVER NATIONAL LABORATORY</p>	<p>Project Partner Test Expertise Past Coupler Expertise ASME Code Expertise</p>
 <p><b>Fiber Glass Systems</b></p>	<p>Project Partner Commercialization Value In-field Expertise</p>
 <p><b>AUTOMATED DYNAMICS</b><sup>®</sup> PART OF TRELLEBORG GROUP</p>	<p>Project Lead Composite Design and Automated Manufacturing</p>

# Challenges & Barriers: Pass Fatigue Test Criteria

- Failure criteria in test: pipe fails before coupler. Expected >10K cycles.
  - Pipe failure means any leak causing steady state pressure drop
  - Evidence in test is stepwise change in pressure driven into system
- Passing this test is critical in achieving 50 year service life

# Challenges & Barriers: Pass Fatigue Test Milestone

- Design Refinements
- Optimize wire spacing
  - Larger spacing between wires is better for more plastic bond area; worse for consistent heat transfer and fusion.
- Electrofusion cycle
  - Use off the shelf electrofusion machine; spec wire (i.e. resistivity) as needed
  - Melt surface, not entire liner
- Manufacturing
- Consistency in wire embedment into HDPE
- Long-term
  - EF plastic/wire portion is molded as typical EF couplers are

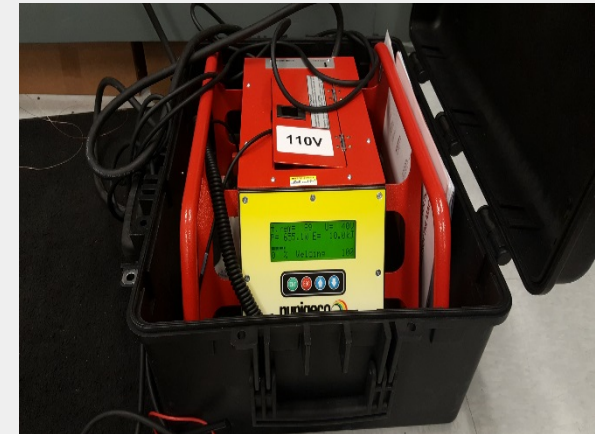



# Proposed Future Work: FY 2018

- **April**
  - Refine process, measure and record fusion data, analyze cross sections
- **May**
  - Send first prototype for fatigue test
- **Q2 Remainder**
  - Successful Fatigue tests take several weeks
  - Adapt design if needed
- **Q3/Q4**
  - Validate new design for Burst and Leak Rate
  - Test as many samples possible for statistical confidence

**Any proposed future work is subject to change based on funding levels.**

# Proposed Future Work: Past FY18

## ■ Commercialization

- Current Project: TRL 3 to TRL 5
- Future: TRL 5 to TRL 9
  - Buy-in from fueling station(s) and pipe supplier(s)
  - Requires detailed cost analysis of FRP compared to steel (outside project scope)

## ■ Cost Evaluation

- Overall cost of FRP solution is driven by cost of pipe, proprietary to NOV. Outside scope of this project.
- Cost of coupler, in volume, is negligible compared to pipe, given lengths at hand.
- Coupler will cost <\$300 Total: <\$20 for custom molded EF Coupler component, <\$250 for machined components.
- Equipment needed for pipe prep and electrofusion: \$20K

**Any proposed future work is subject to change based on funding levels.**

# Technology Transfer Activities

- Patent Application on Coupler submitted 2017
- Future commercialization plans include proposing idea to pipe suppliers and re-fueling stations.

# Summary

- Challenge is rigorous to seal against fatigue stress.
- Remaining goal: pass sequential fatigue and leak rate tests. (Achieved Targets on Leak rate in isolation).
- Commercialization and cost of FRP H2 lines is largely a function of FRP cost. Coupler is a necessary detail.