



Hydrogen Fueling Infrastructure Research and Station Technology

## Dispenser Reliability 2019 DOE Annual Merit Review

**Presenter: Mike Peters<sup>1</sup> (PI)**  
**Nalini Menon<sup>2</sup>, Matt Ruple<sup>1</sup>, Josh Martin<sup>1</sup>, Erin Winkler<sup>1</sup>,**

**<sup>1</sup> National Renewable Energy Laboratory**

**<sup>2</sup> Sandia National Laboratories**

**April 30, 2019**

This presentation does not contain  
any proprietary, confidential, or  
otherwise restricted information.

Project ID # in008

## T I M E L I N E

- Start date: 10/1/2016
- End date: 09/30/2019\*

\* Project continuation and direction determined annually by DOE

## B A R R I E R S

### Multiyear RD&D Barriers

#### ***Technology Validation Barriers***

- **D.** Lack of Hydrogen Refueling Infrastructure Performance and Availability Data
- **E. Codes and Standards** - *Validation projects will be closely coordinated with Safety, Codes and Standards*

## B U D G E T

### Project funding:

- **NREL**
  - FY19: \$266k (carryover)
  - Project Total: \$1,740k
- **SNL**
  - FY19: \$590k
  - Project Total: \$677k

## P A R T N E R S

### Funded

NREL: Hardware testing and lifetime analysis

SNL: Material testing\*

\*SNL presenting their work at AMR poster session  
Title: Dispenser Reliability R&D: Materials Compatibility

### Close Collaboration

Walther-Präzision GmbH & Weh GmbH:  
Material consulting and lifetime monitoring

## Dispensers are the top cause of maintenance events and downtime at retail hydrogen stations

Maintenance by Equipment Type - Retail Stations

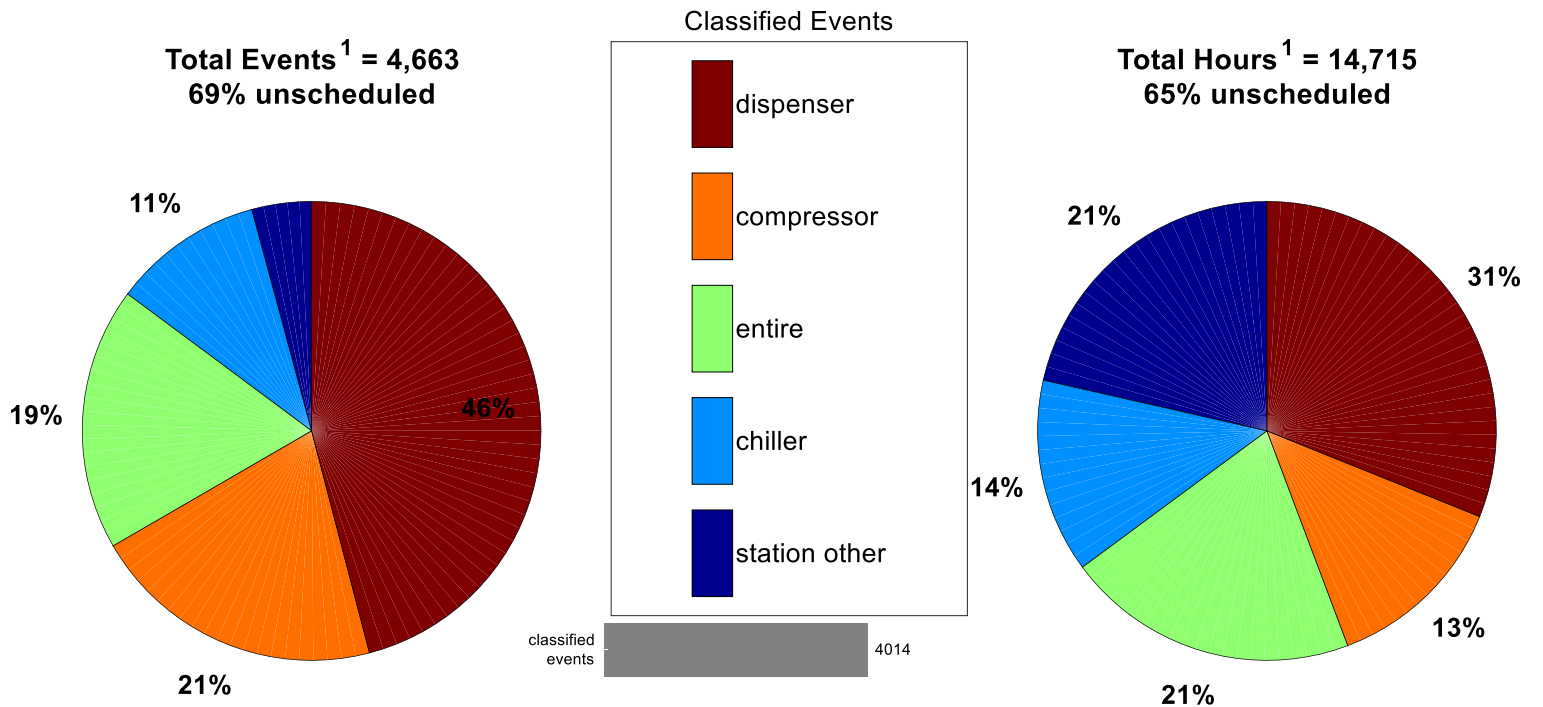

MISC includes the following failure modes: feedwater, electrolyzer, thermal management, storage, safety, gas mgmt panel, air, electrical, other

1. Total includes classified events (plotted) and unclassified events.



NREL cdpRETAIL\_infr\_21

Created: May-07-18 1:50 PM | Data Range: 2014Q3-2017Q4

- There are some test campaigns on performance of piping components at the pressures and temperature in a fueling dispenser, but:
  - Available information is qualitative only, or
  - Results of specific qualification tests do not assess effects other than pass/fail
- SNL adds an additional level of detail with material characterization pre and post exposure to hydrogen
  - Early results shown at the poster session





# Approach: Accelerated Reliability Testing



*Measure the mean fills between failures (MFBF) and mean kilograms between failures (MKBF) of hydrogen components subjected to pressures, ramp rates, and flow rates similar to light duty fuel cell electric vehicle fueling at -40°C, -20°C, and 0°C*

Devices Under Test (DUTs):

- Nozzles, breakaways, normally closed valve, normally open valve, filter

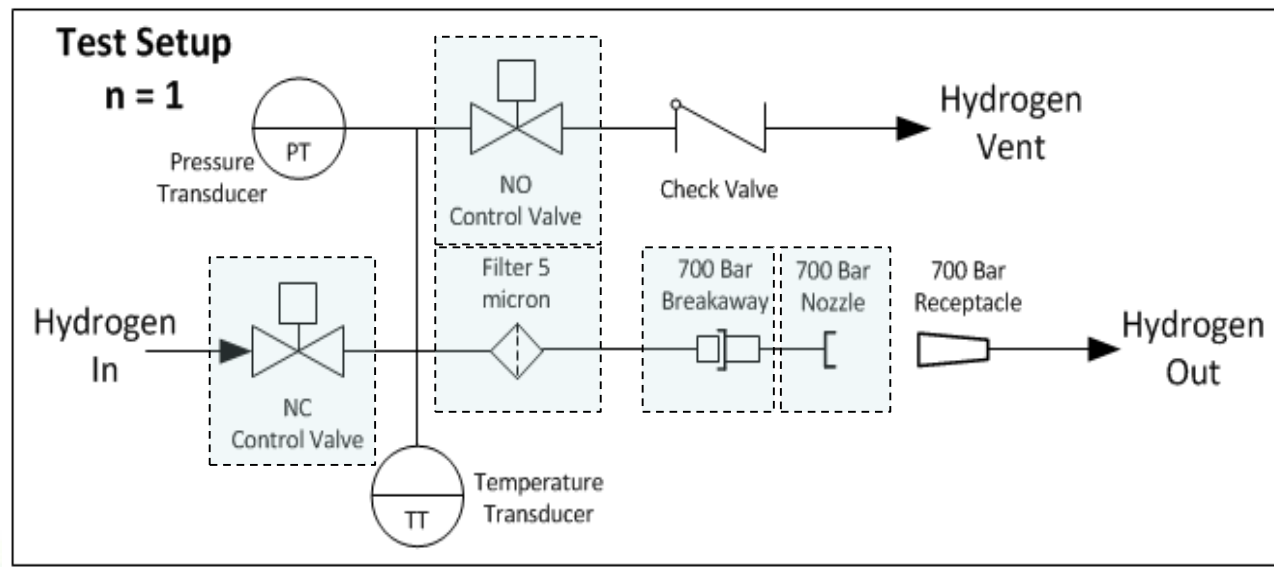

# Approach: Recirculation System

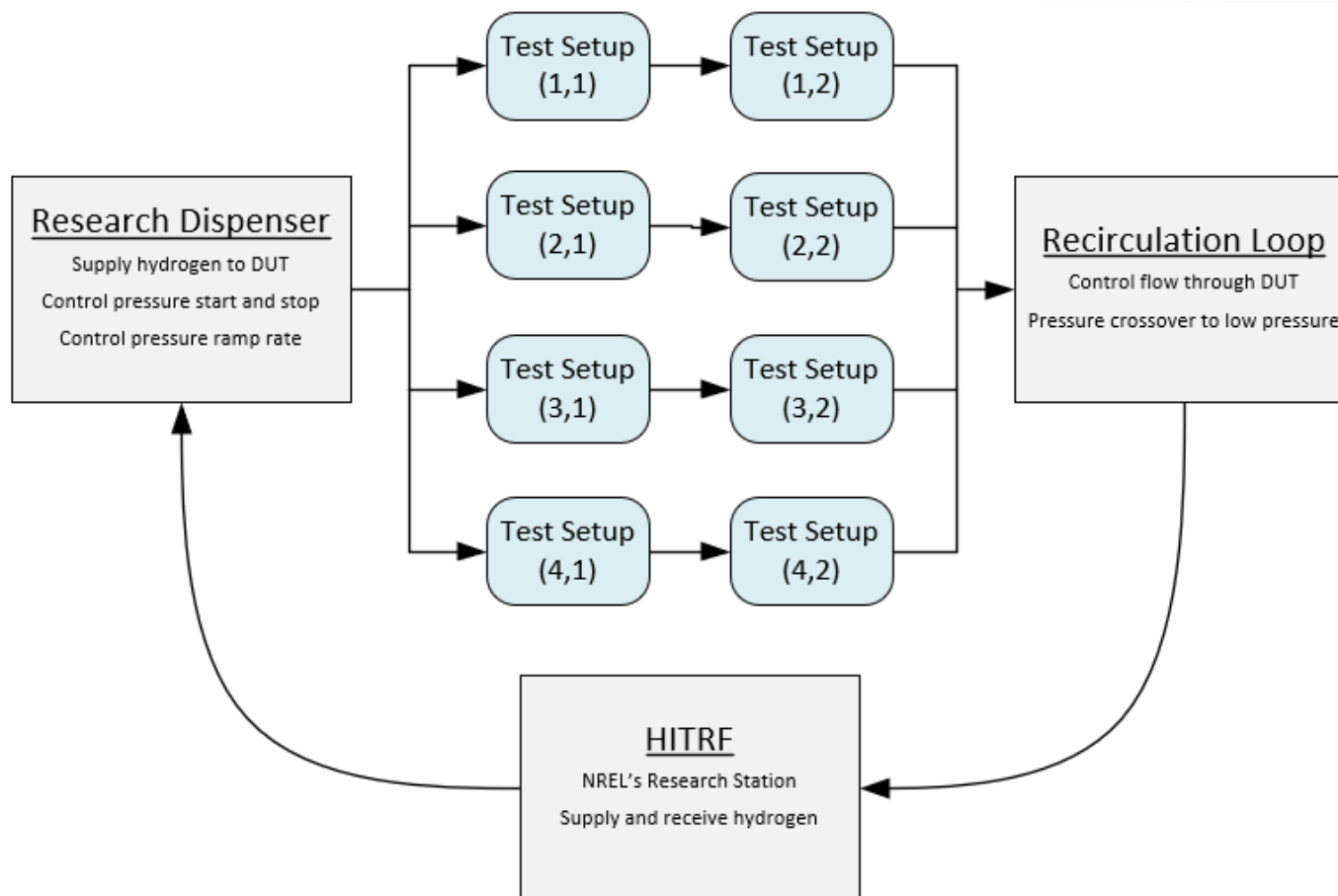

## *Leak Detection: Sensors and Mass and Pressure Tracking*

- The system looks for leaks with two different methods: mass calculation using the PVT method and hydrogen sensors

## *Material Testing: SNL to perform polymer characterization on components to establish material requirements*

- First efforts will involve establishment of baseline properties on polymers not exposed to H<sub>2</sub>
- Baseline properties will be compared to polymeric materials from failed and passed components



# Accomplishment: Average Retail Fill Profile

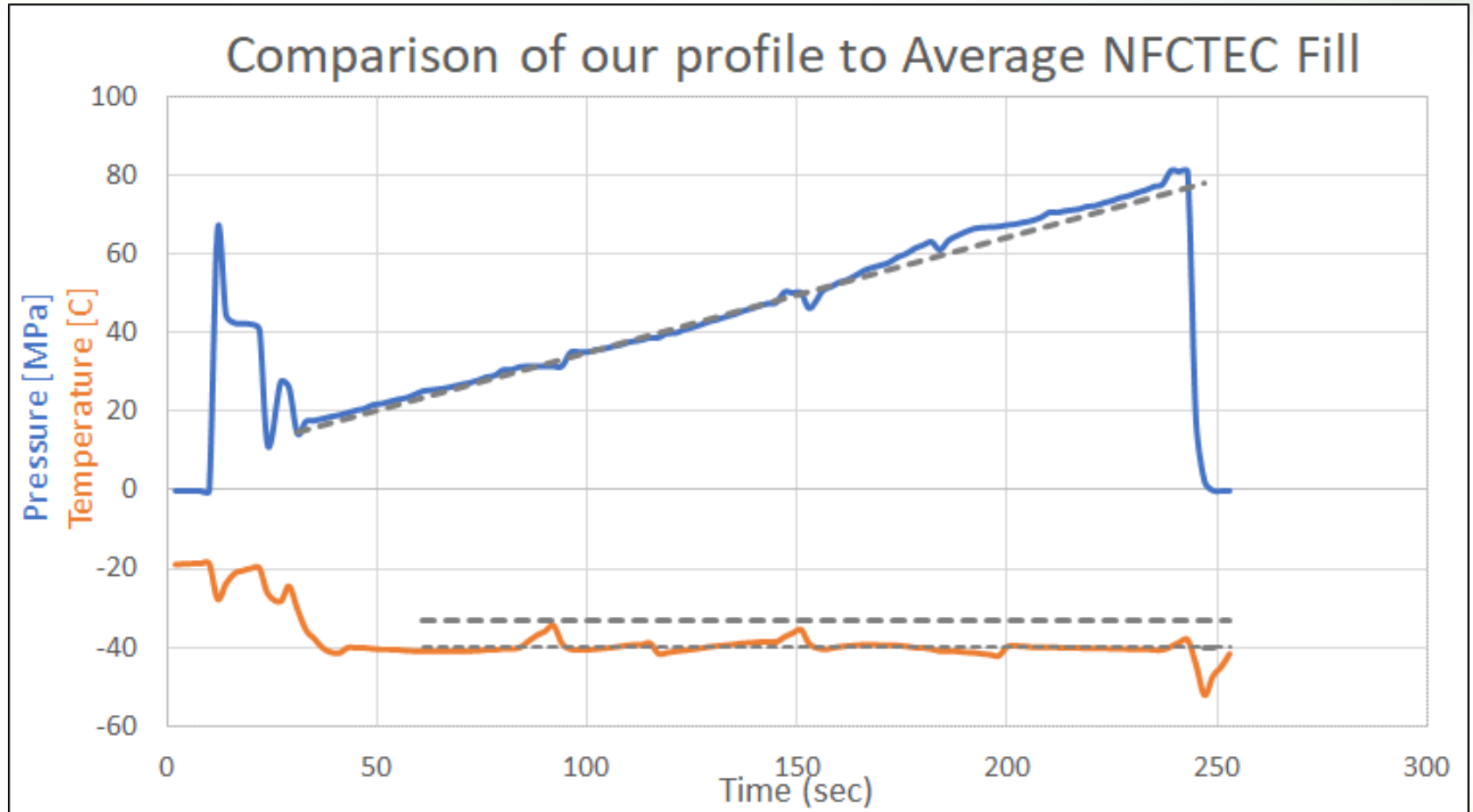



<u>Cycle Count</u>		<u>Kilograms through DUTs</u>		<u>Total DUTs</u>	
0		0		40	
<u>Leaks Detected</u>		<u>Failure Tracking</u>			
DUTs	BoP	Part Removed		Fixed in Place	
0	0	0		0	

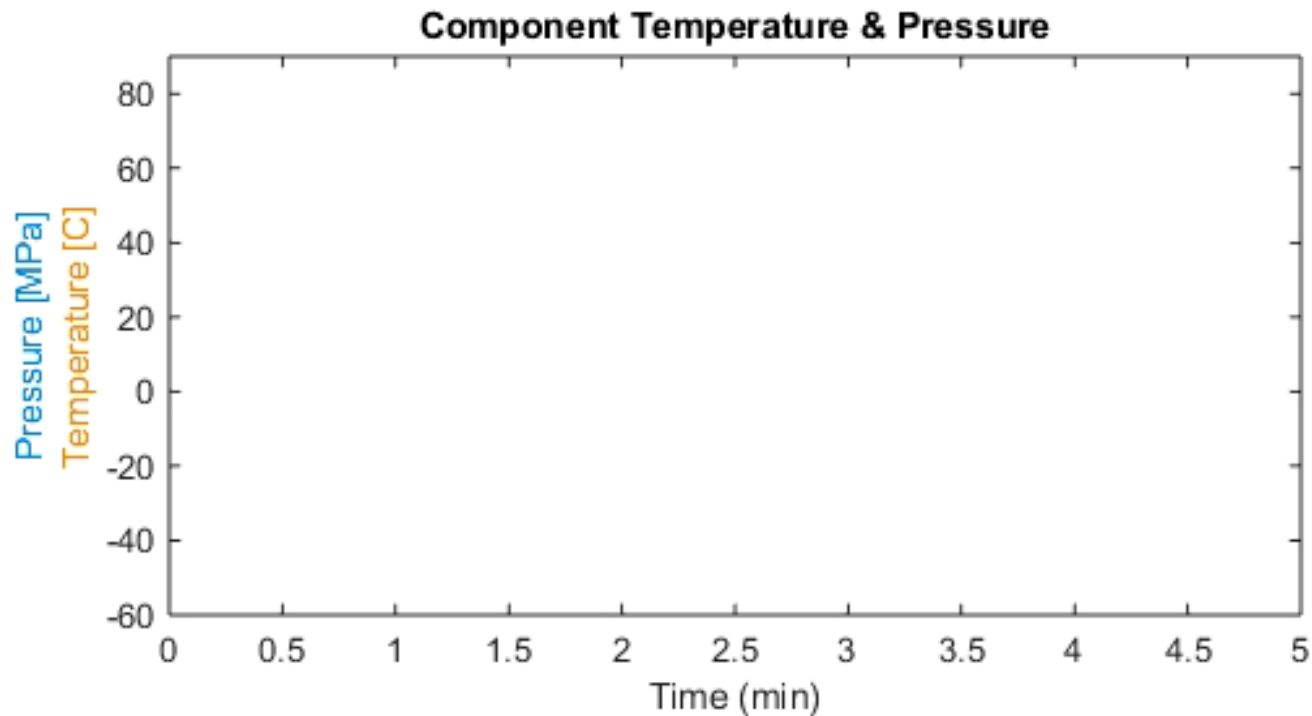

# Accomplishment: First Failure



<u>Cycle Count</u>		<u>Kilograms through DUTs</u>		<u>Total DUTs</u>	
108		124.2		40	
<u>Leaks Detected</u>		<u>Failure Tracking</u>			
DUTs	BoP	Part Removed		Fixed in Place	
1	0	2		0	

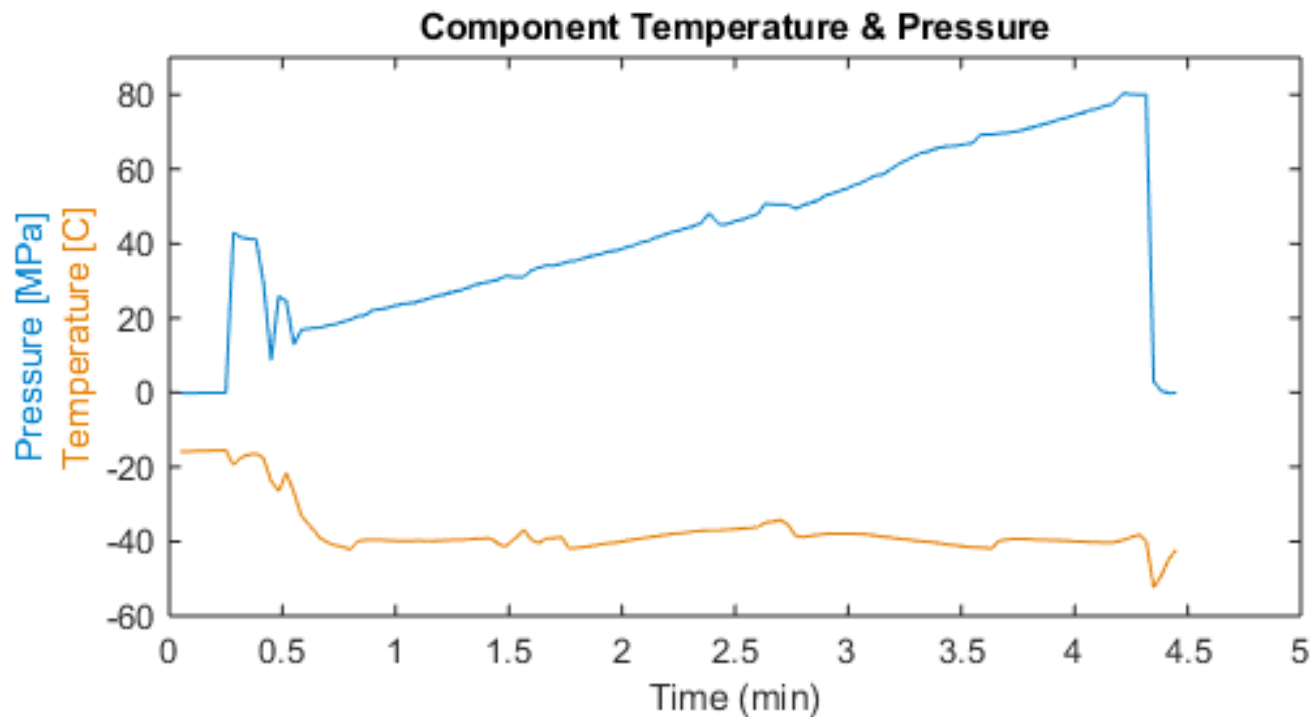

<u>Cycle Count</u>		<u>Kilograms through DUTs</u>		<u>Total DUTs</u>	
108		124.2		40	
<u>Leaks Detected</u>		<u>Failure Tracking</u>			
DUTs	BoP	Part Removed		Fixed in Place	
1	0	2		0	

Component Temperature & Pressure

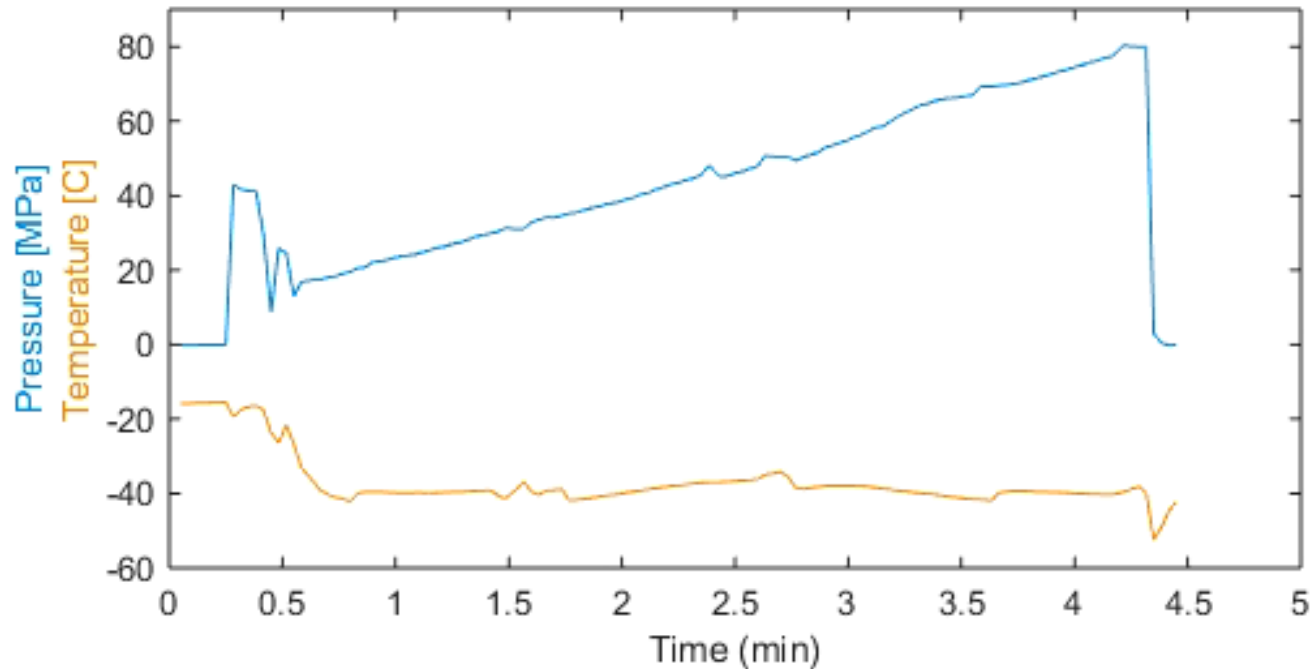

# Accomplishment: Manufacturing Setpoint

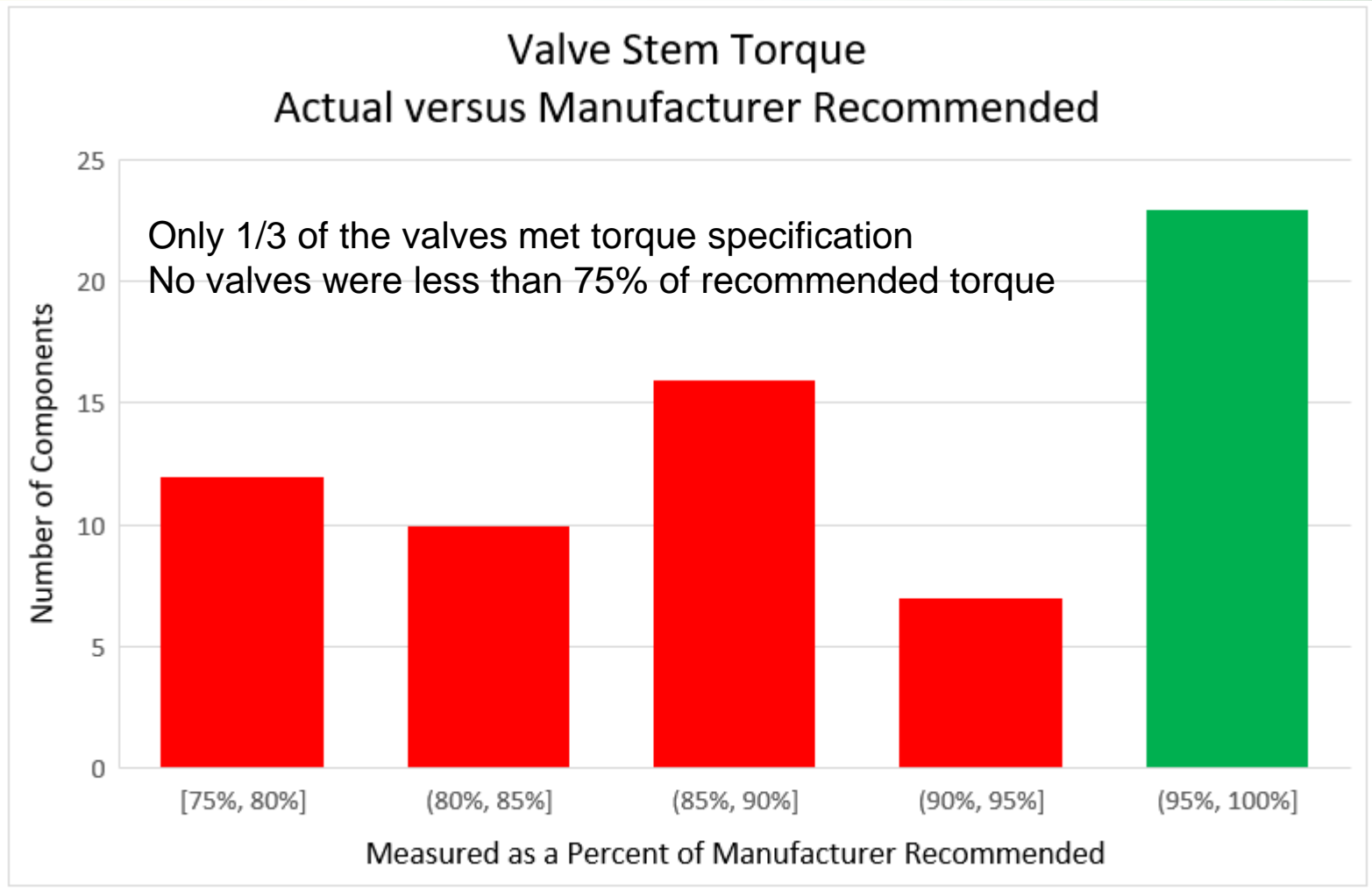



<u>Cycle Count</u>		<u>Kilograms through DUTs</u>		<u>Total DUTs</u>	
131		151.9		42	
<u>Leaks Detected</u>		<u>Failure Tracking</u>			
DUTs	BoP	Part Removed	Fixed in Place		
3	0	2	1		

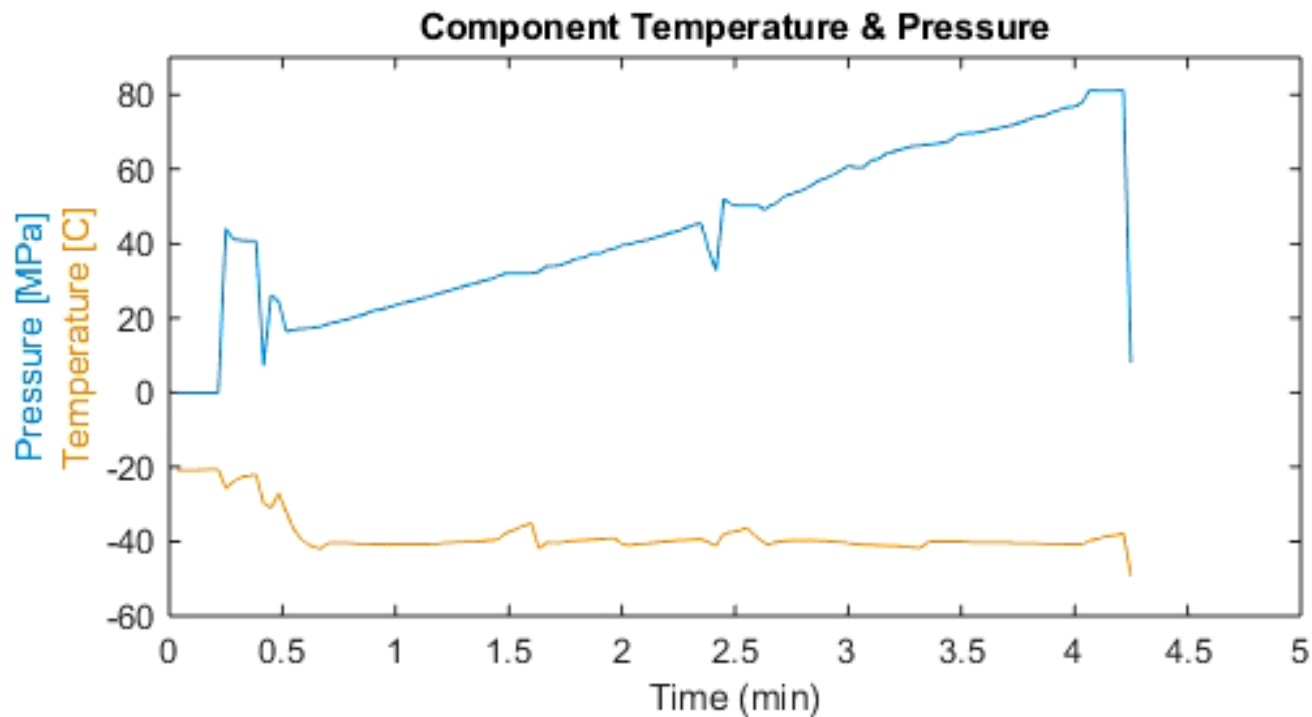

# Accomplishment: Leaks Resealing After Downtime

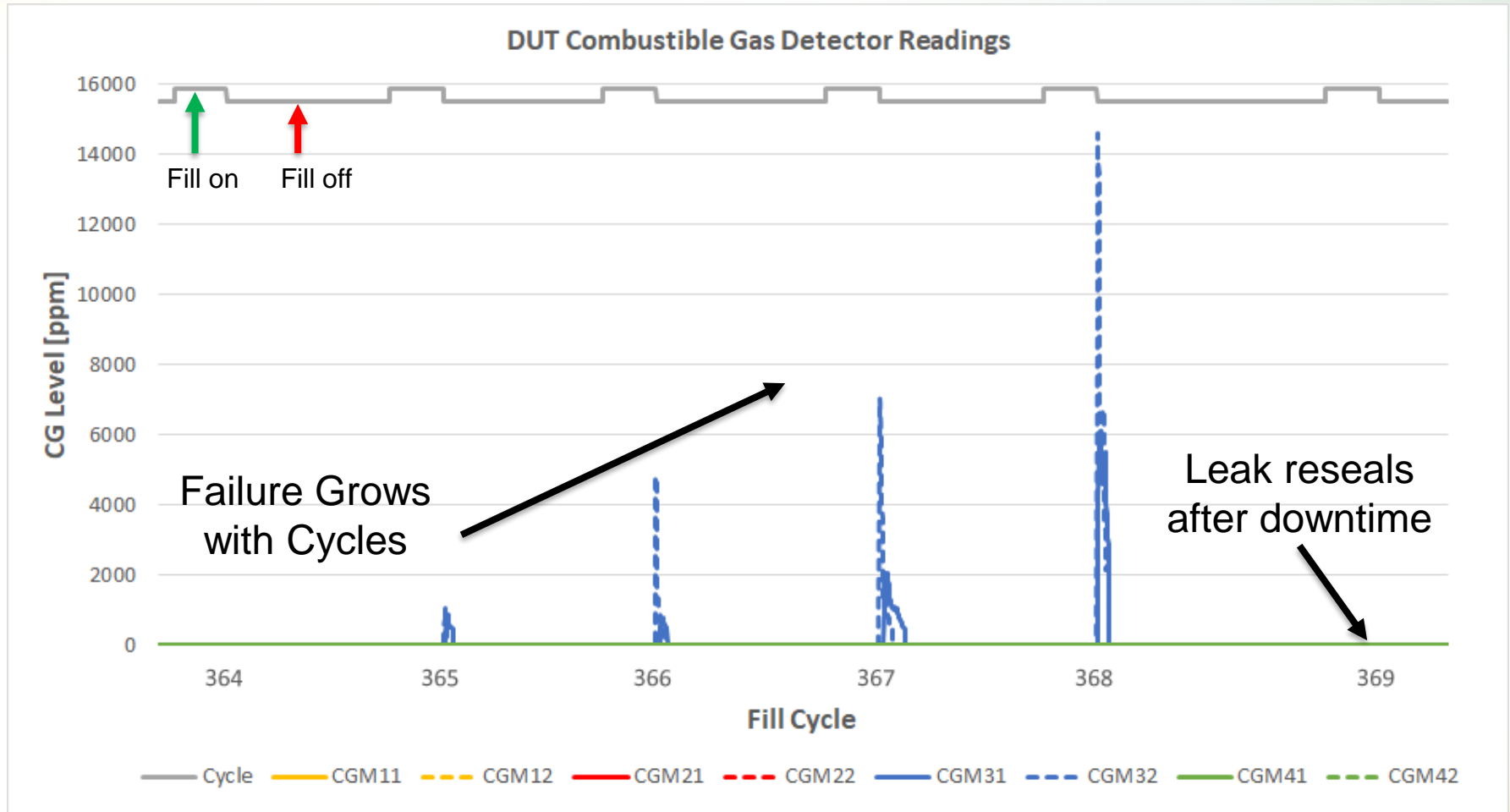

<u>Cycle Count</u>		<u>Kilograms through DUTs</u>		<u>Total DUTs</u>	
369		428.5		46	
<u>Leaks Detected</u>		<u>Failure Tracking</u>			
DUTs	BoP	Part Removed	Fixed in Place		
15	10	7	16		

Component Temperature & Pressure

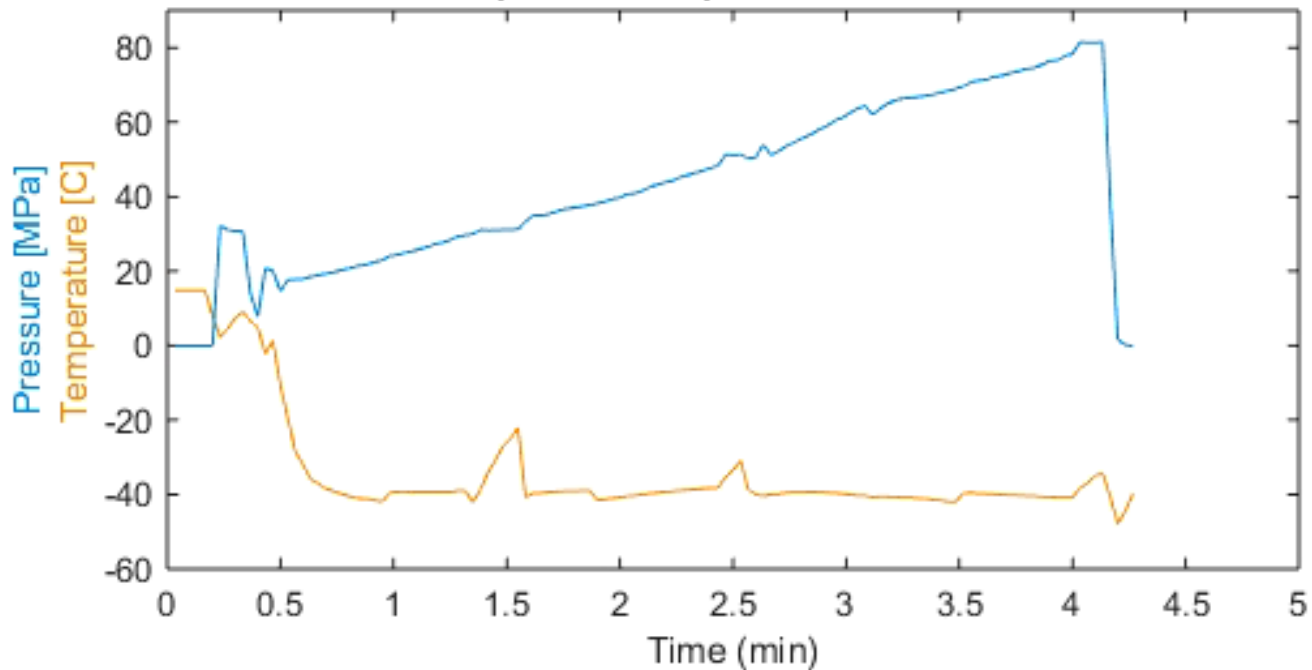

# Accomplishment: Last Cycle to Date



<u>Cycle Count</u>		<u>Kilograms through DUTs</u>		<u>Total DUTs</u>	
575		655.1		56	
<u>Leaks Detected</u>		<u>Failure Tracking</u>			
DUTs	BoP	Part Removed	Fixed in Place		
21	13	9	21		

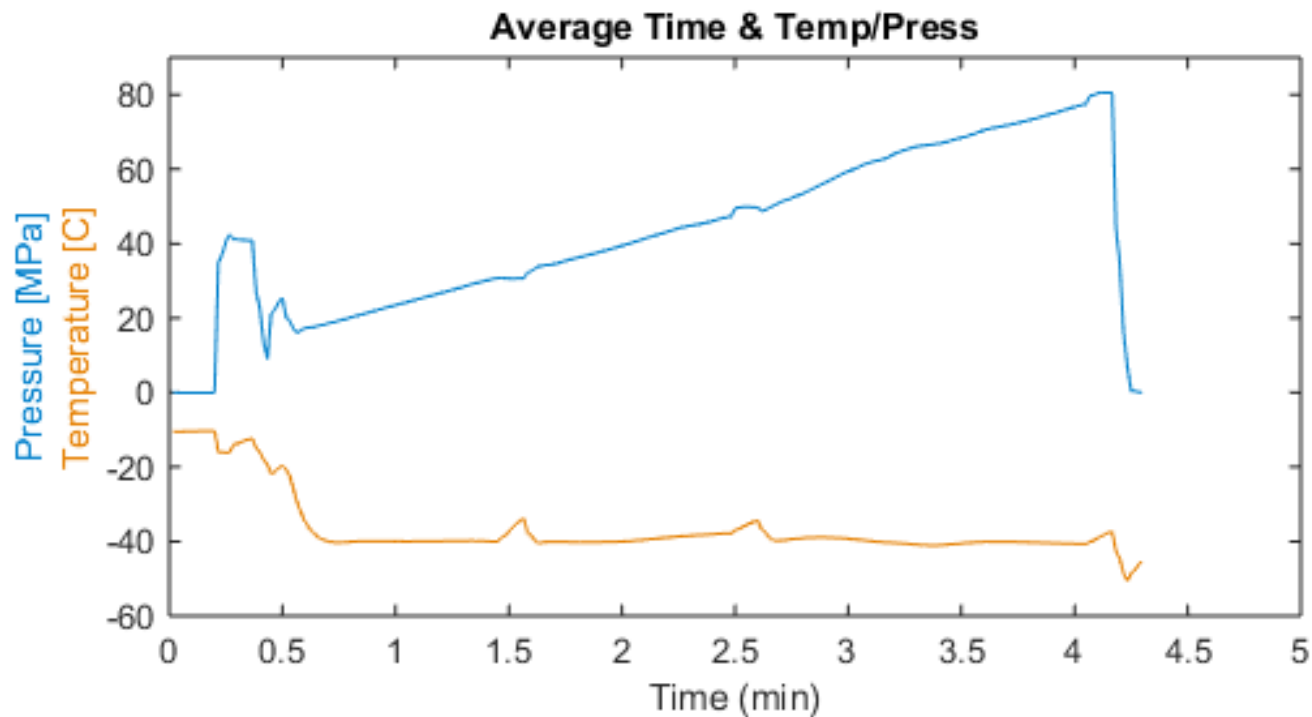



# Progress: Preliminary Statistical Analysis



- Number of cycles and censoring indicator fit a Weibull distribution with shape parameter ( $\hat{\beta}$ ) 1.7 and scale parameter ( $\hat{\eta}$ ) of 422
- A  $\beta$  of 1 is most ideal implying random failures independent of time (old part = new part)
- $\beta$  of 1 means hazard rate remains constant

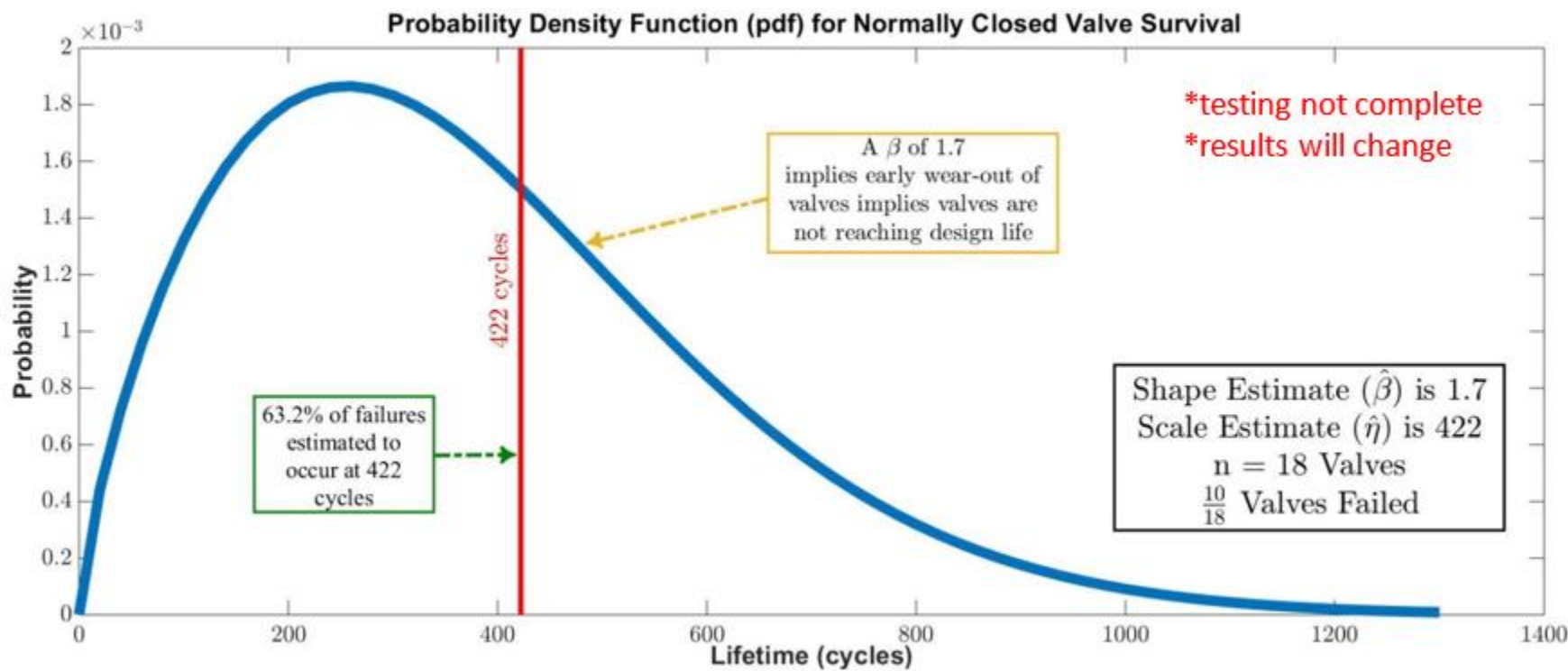

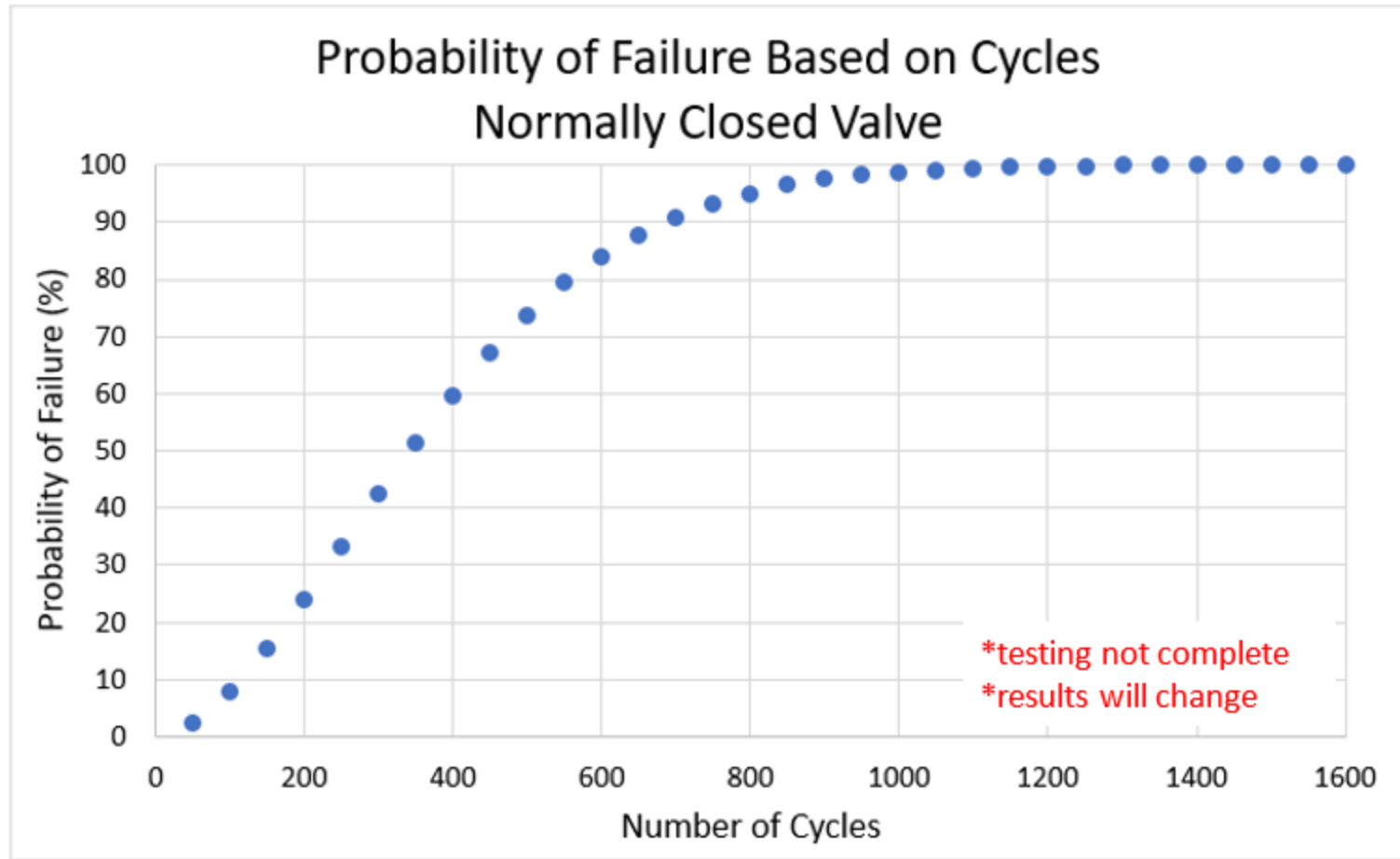

***Reviewer: Now that all the preliminary work is complete, the next phase of the project (actual testing) is the most important and should be given time to continue. It looks as though the project is slated to be complete by the end of September, but consideration should be given to the team's continuing testing until multiple failures have occurred and there is enough data to draw conclusions.***

Response: Our project continuation is determined annually, as indicated by last year's slides, but the plan is for the project to end in September of 2019. Gaining enough failure data to make strong conclusions on the lifetime of the components is essential to the success of this project. Cycles will continue to be collected at each temperature level until there is enough data to make these conclusions. So, if we get to September and still need more cycles (and have money) we will continue.

***It is not clear what materials analysis will be provided to materials manufacturers. It is also not clear that a well-thought-out process is in place for such an analysis.***

Response: For the material analysis, we have a great partnership with Sandia National Laboratories on this project but it is hard to fit all of the project information into one 20 minute presentation each year. DOE has accommodated this issue by enabling SNL to have a poster this year: Dispenser Reliability R&D: Materials Compatibility. Please go visit their poster tonight for more information about the material analysis. Next year, we plan on having two separate orals: 1) Component testing and lifetime analysis and 2) Material analysis and conclusions.

## Component Manufacturers

- Team has secured NDAs to discuss material analysis and testing with Walther and Weh
  - Walther visited NREL September, 2018
  - Weh Visited NREL June, 2018





## Time it Takes to Perform Lifetime Testing

- The project team needs to ensure that enough failures occur that solid conclusions can be made. Sometimes this can take longer than expected.



- The team has concerns around the role of ambient temperature and/or humidity as it relates to failures occurring
  - Colder + more humid ambient conditions seems to indicate a higher likelihood of failures – testing will prove/disprove this
- What does a leak mean in terms of \$ lost to the station operator?
  - Time to get to leak + time to fix a leak + lost revenue during that time
- If a component leaks and then reseals is that okay? Does it depend on leak rate and/or potential for exposure?
- Once testing is complete the statistical analysis will be able to predict the likelihood certain components last 1 week, 1 month, 1 year, or any given time
  - Initial work on early detection of failure

*Any proposed future work is subject to change based on funding levels.*

# Future Work: Project Level



- Continue -40°C until there is enough data to make statistical conclusions
- Complete -20°C and 0°C testing
- Continue to send failed/non-failed samples to SNL for analysis
- Report findings out to public



*Any proposed future work is subject to change based on funding levels.*



- Relevance
  - Dispensers are top cause of downtime in the field
  - Component testing is beneficial to better understand the effects of temperature on these components
- Approach
  - Perform accelerated life testing of components to failure under different temperature conditions
  - Define field-like test requirements
  - Design system capable of testing multiple dispensers at once
- Accomplishments
  - Operated system for 575 cycles at -40°C
  - Experienced 34 leaks during that duration and removed 9 parts
  - Observations have been made related to low temperature/high humidity ambient conditions leading to a higher failure rate
- Future Work
  - Testing will continue with -20°C and 0°C testing starting soon
  - SNL will continue with the material analysis
  - Provide feedback to industry and the public

Michael Peters – NREL – [Michael.Peters@NREL.gov](mailto:Michael.Peters@NREL.gov)

Nalini Menon – SNL – [ncmenon@sandia.gov](mailto:ncmenon@sandia.gov)

**THANK YOU**



# TECHNICAL BACKUP SLIDES

# Approach: Simulate Retail Fills

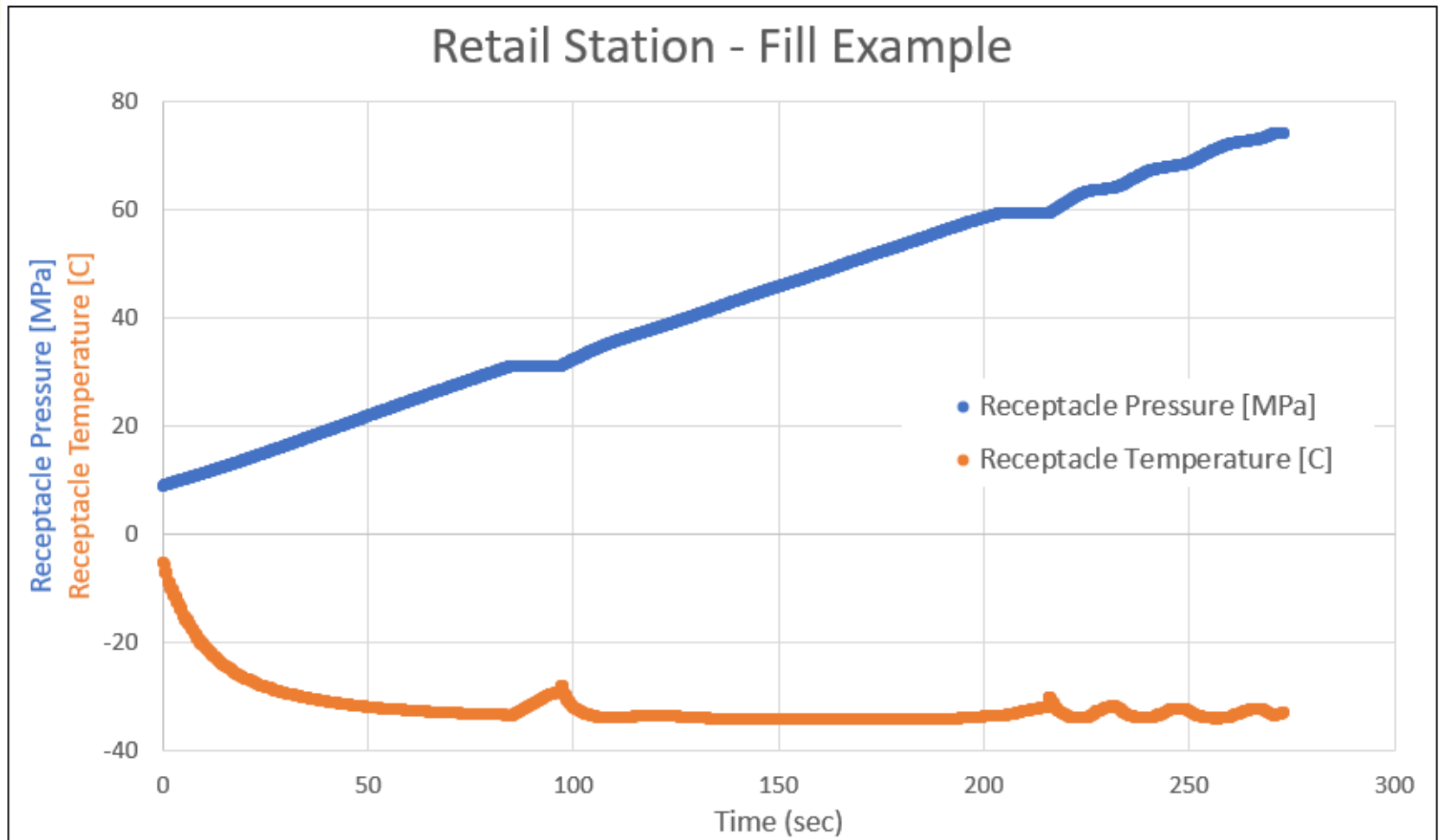

## Variable Factors

### Controlled

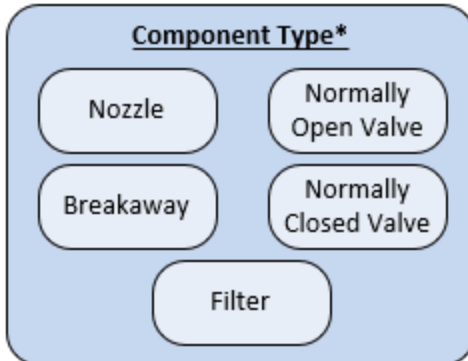
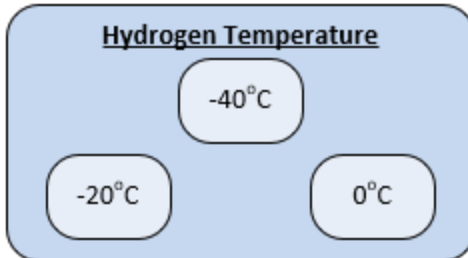

### Uncontrolled

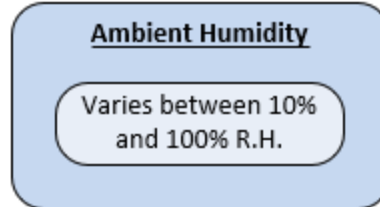
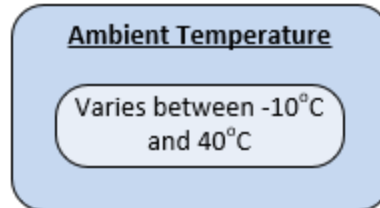

## Fixed Factors

### Controlled

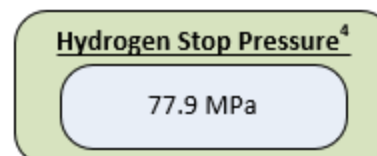
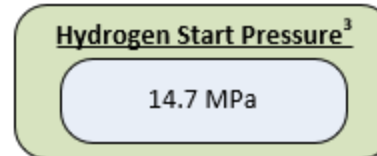
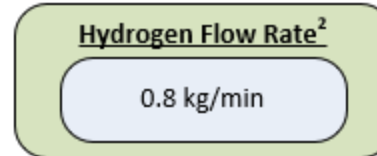

## Response Variables

### Unpredictable

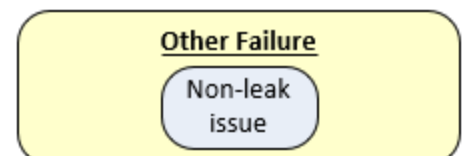
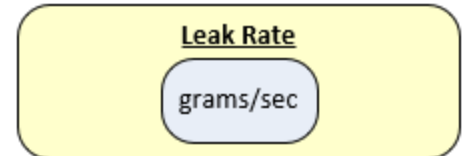
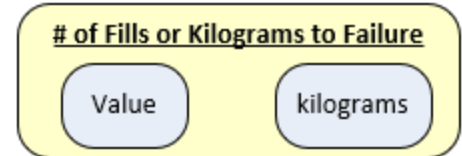
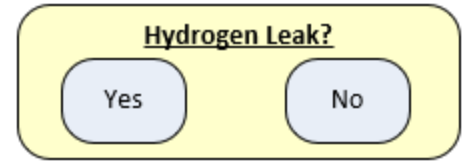

\*Components can be broken into subgroups by manufacturer but individual company performance will not be reported. Each component type has two manufacturers.

Sources: Fill Time (1) - <https://www.nrel.gov/hydrogen/assets/images/cdp-retail-infr-03.jpg> Hydrogen Flow Rate (2) - <https://www.nrel.gov/hydrogen/assets/images/cdp-retail-infr-02.jpg> Hydrogen Start Pressure (3) - [https://www.nrel.gov/hydrogen/assets/images/cdp\\_fcenv\\_15.jpg](https://www.nrel.gov/hydrogen/assets/images/cdp_fcenv_15.jpg) Hydrogen Stop Pressure (4) - <https://www.nrel.gov/hydrogen/assets/images/cdp-retail-infr-09.jpg>

- Kaplan Meier: a nonparametric way to estimate reliability functions ( $\hat{R}(t)$ )
  - Estimates the probability the life is longer than  $t$
  - Estimates time-to-failure of parts
- Kaplan Meier gives insight into true underlying lifetime distribution of parts
  - In this case, the Kaplan-Meier estimator fits to a Weibull reliability function
  - $\hat{R}(t)$  estimates 50% of failures to occur at 217 cycles
- An estimate for a distribution gives parameters to compute time-between-failures, mean-time-to-fails and so on
- Can aid in determining cost-efficacy of repairing or replacing parts

## Kaplan-Meier Estimate of Reliability Function

