

NREL Hydrogen Sensor Testing Laboratory

William Buttner, P.I. and Tashi Wischmeyer*
National Renewable Energy Laboratory

* Intern, University of Colorado, Boulder

DOE Hydrogen and Fuel Cells Program
2019 Annual Merit Review and Peer Evaluation Meeting
April 29 to May 1, 2019

Project ID # SCS 021

Overview

Timeline and Budget

- Project start date:
10/01/2010
- FY18 DOE funding * :
\$ 250 K
- FY19 planned DOE funding #:
\$ 534 K
 - Including ~40% for 2 subcontracts
- Total DOE funds received to date:
\$ 3090 K

*Owing to budget uncertainties, the NREL Sensor Laboratory did not receive FY2018 funding until Q3-Q4.

The NREL Sensor Laboratory was under the NREL Safety Codes and Standard Group AOP since 2010. A separate AOP was granted in 2019.

Barriers

- C. Safety is not always treated as a continuous process**
- F. Enabling national and international markets requires consistent RCS**
- G. Insufficient technical data to revise standards**

Partners

Industry: component manufacturers, automotive OEMs, Element One, KWJ, Linde, AVT, First Element, CGA/Chart

CDOs/SDOs: SAE, NFPA 2, ASTM

Government labs and agencies: JRC, DOT-NHTSA / Transport Canada / Environment Canada, CaFCP, SNL, LLNL, NREL (cross-cutting programs), HySafe, HSE/HSL (UK)

Academic: Colorado School of Mines, University Colorado, Georgia Institute of Technology, Colorado School of Mines

Relevance: What is a sensor?

Sensing Element vs. Sensor vs. Analyzer

Sensing Element: Interaction with stimuli and transduction into electrical signal

- Different Platforms (CGS, TC, EC, MOX, etc.)

Sensor: Provides quantitative information

- Sensing Element(s) integrated with electronic circuitry (convert sensing element electrical response to useful signal)

Detection Apparatus (Analyzer, etc.):

- Quantitation, Alarms, and Control Functions

Sensor vs. Sensing Element vs. Analyzer

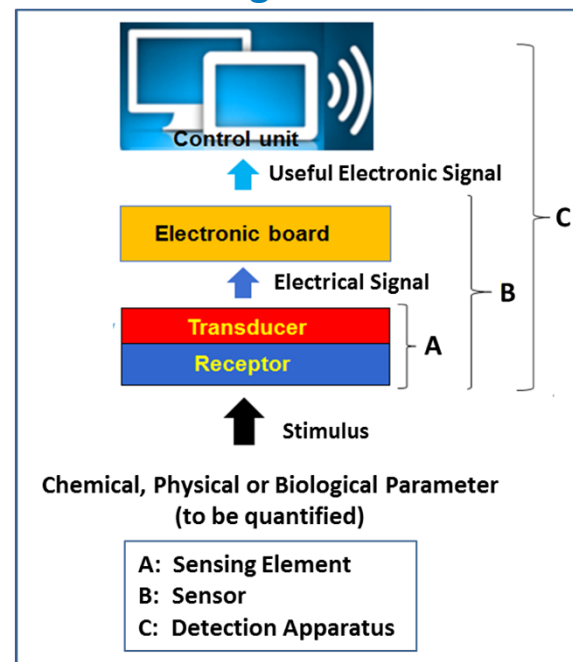

vs.



vs.



Sensing Element (\$10 to \$100)
(analog signal)

Sensor (\$50 to \$500)
(vol% H₂)

Analyzer (>\$500)
(Control Functions)

The term “*sensor*” can have different meanings among stakeholders within the hydrogen community. Clarification is necessary to minimize confusion.

Relevance

Need for Continued RD&D

“H₂ Sensors Don’t Work”

- Not true
- Not totally untrue
 - 1/3 of sensors tested out of spec.
 - Unacceptable failure rate in the field
 - Wrong sensor for application

Emerging Markets and Expectations

- New applications (end-users)
- New sensor technology
- Integrated active monitoring for enhanced facility safety

Expectations of Performance

- Improper use/wrong sensor
- Critical gaps
 - Sensor lifetime / deployment stability
 - Cost of ownership
 - Guidance on placement/location; H₂ Wide area monitoring (HyWAM)—2018 HySafe RPW

H₂ Sensors Supports Safety Research

- Sensor developers RD&D
- Pre-normative research in support of C&S development (hydrogen dispersion behavior)

Distributed vertical profiling of a LH₂ Release



The NREL Sensor Laboratory developed a multipoint monitoring system for the profiling of hydrogen releases, which can be the basis for a hydrogen wide area monitor (HyWAM) **(NREL Provisional Patent Prov 18-28)**

Approach: Mission and Strategy of the NREL Sensor Testing Laboratory

The NREL Hydrogen Sensor Testing Laboratory RD&D effort is guided by the needs of the hydrogen community.

- **Laboratory performance assessment**
 - Commercial and developing technologies
 - Qualification for end-users and applications
 - Performance verification NOT certification
 - Support infrastructure and vehicle clients/applications
- **Field Deployments**
 - Verification tools for regulation requirements (e.g., GTR)
 - Validation for specific end-user applications
 - Infrastructure safety and implementation (HyWAM)
 - Indoor and outdoor facilities
 - Medium to large scale facilities
 - Elucidation of release behavior--GH₂ and LH₂ safety research
- **Strategic partnerships to support RD&D**
 - Government agencies and research institutions
 - National and International Partnerships
 - Regulators, infrastructure, and OEMs
 - Support C&S Development and safety
 - Provide tools for pre-normative research and document development
 - Client Confidentiality



H₂ Sensor Testing Apparatus

The NREL Sensor Laboratory is a resource to the hydrogen community

Approach: Sensors and Mitigation — Evolving mission for hydrogen sensors and the NREL Sensor Testing Laboratory

Traditional Focus (performance evaluation)

- Sensors provide critical safety factor
 - Provide warning before unsafe conditions
 - Activate Corrective Measures (ventilation)
 - Focus: metrological performance (RT, Range)

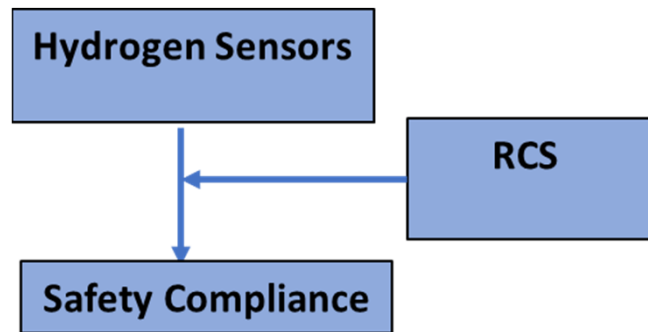

Assurance of Performance for General Safety Compliance

Emerging focus (integration into QRA)

- Temporal and spatial H₂ measurements
 - Tool for hydrogen behavior (validated CFD)
 - To integrate with QRA for facility design
 - Impacts safety and footprint

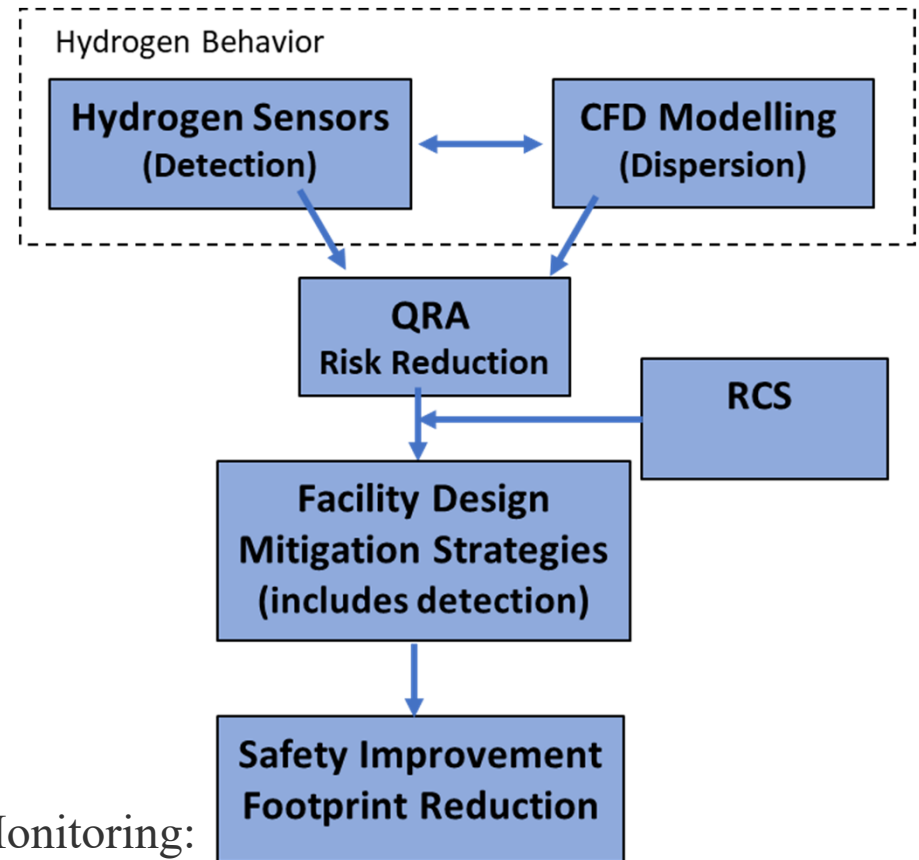

Active Monitoring:
One strategy for risk reduction

Accomplishments (update): Support of sensor development and infrastructure safety

Support of new sensor technology

- Private Partnerships (SBV, NDA, WFO)
- Address critical gaps on sensors
 - Low-cost manufacturing (economy of scale) to assure supply and low cost
 - Unique sensor capabilities (low-cost, wireless, etc.)
- National Laboratory provides resource not otherwise available

Sensor and Design Qualification

- NREL “HyWAM” sensors (H₂ behavior) (laboratory and field assessment)
- Hi Pressure Component Reliability Testing (laboratory and field assessment)

Sensor testing remain a core capability

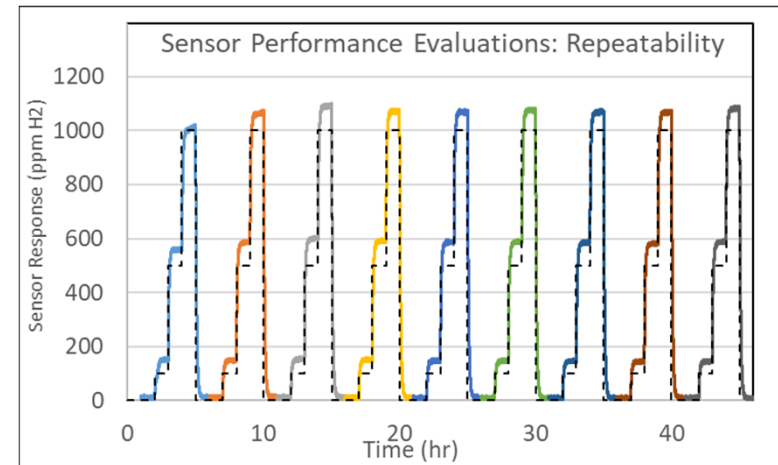

(Extracted from. “Characterization of a Selective, Zero Power Sensor for Distributed Sensing of H₂ in Energy Applications” T. Wischmeyer et al., Sen. and Act. (Dec 2018). Work performed with KWJ under the DOE SBV.

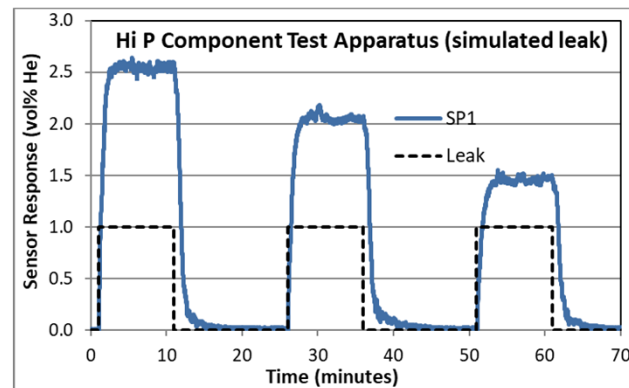

Apparatus for high P H₂ component testing. The Sensor Lab qualified sensors for the apparatus 24/7 operation. Leaks associated with failed components are quickly detected by hydrogen sensors.

Accomplishments and Progress: Support of C&S: SAE TIR J3089



SURFACE VEHICLE TECHNICAL INFORMATION REPORT (TIR)	J3089™	OCT2018
	Issued	2018-10
Characterization of On-board Vehicular Hydrogen Sensors		

Publication of SAE J3089

Characterization of On-Board Vehicular Hydrogen Sensors

Background

- Document development was led by NREL Sensor Laboratory under the auspices of the SAE Fuel Cell Standards Committee
- Supports OEM and suppliers on characterization of sensors for on-board FCEV applications.

Update

- Published (October 2018) and available (https://saemobilus.sae.org/content/j3089_201810)

**Codes and standards enhance safety and facilitate commercialization.
The TIR provides a uniform performance assessment guide for sensor suppliers and OEMs.**

Accomplishments and Progress: Support of C&S: FCEV Exhaust Analyzer GTR-13 Verification

GTR 13 (overview)

- Basis for the development for the FMVSS/CMVSS
- Prescribed FCEV H₂ exhaust level requirements

NREL FCEV Exhaust Analyzer (for hydrogen)

- H₂ Detection Technology for GTR-13 verification
 - Supported under DOT-NREL IAG 17-2046; partners include TCa and ECCCa
 - Performance verified in the on FCEV under load
 - Field deployment on FCEV reschedule for 2019 (ECCC/TC)
 - NREL ROI and 2019 ICHS paper

Photo by M. Veenstra/Ford, Used with permission

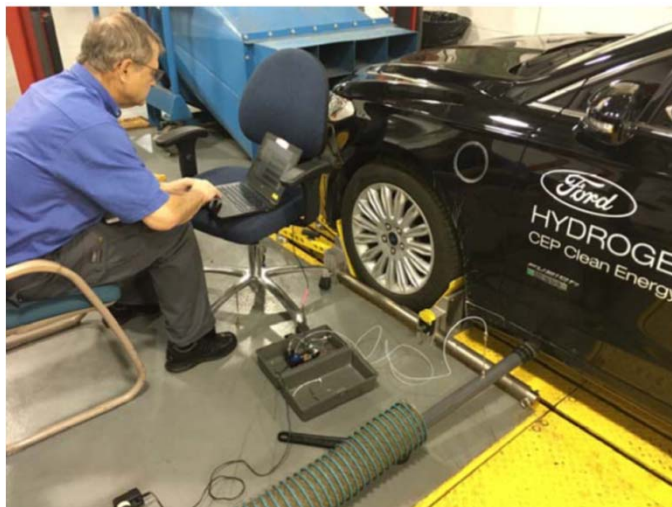
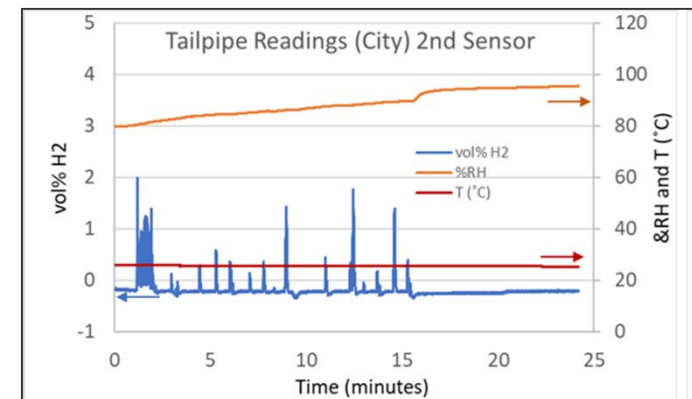
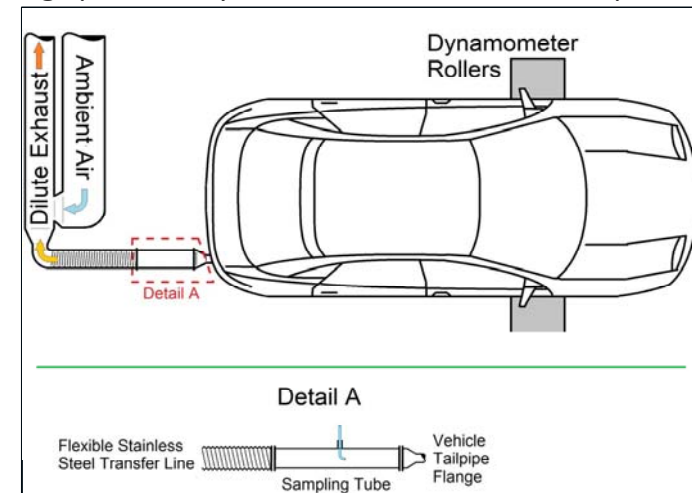

Image provided by A. Loisel/ECCCa, used with permission



H₂ transients in FCEV exhaust operating under load, as measured by the NREL FCEV Exhaust Analyzer

Regulatory requirements need a means to verify compliance. The NREL FCEV Exhaust Analyzer meets the GTR metrological requirements for compliance verification. .

Accomplishments and Progress: Guidance on Sensor Placement (Indoor HyWAM Application)

CFD modelling and empirical verification of indoor hydrogen releases

Guidance on H₂ Sensor Placement

Background

- Identified as H₂ sensor gap in HySafe RPW (Sept 18)
- Initial test system (small scale): ISO container (hydrogen production units with internal compressor)

Status and Plans

- CFD modelling by AVT, Inc. (with DOE support) and affirmed by JRC modelling, validated by NREL HyWAM
 - 10 sensor points for spatial and temporal profiling
 - Excellent temporal and spatial correlation
- Preliminary guidance document for sensor placement and facility design
 - Joint 2019 ICHS presentation; goal to go into NFPA 2

Future Activity

- Integration into QRA (e.g., HyRAM) for risk reduction
 - Strategic Partners include SNL and NFPA 2 Storage Group
- Expand to “large scale facility”

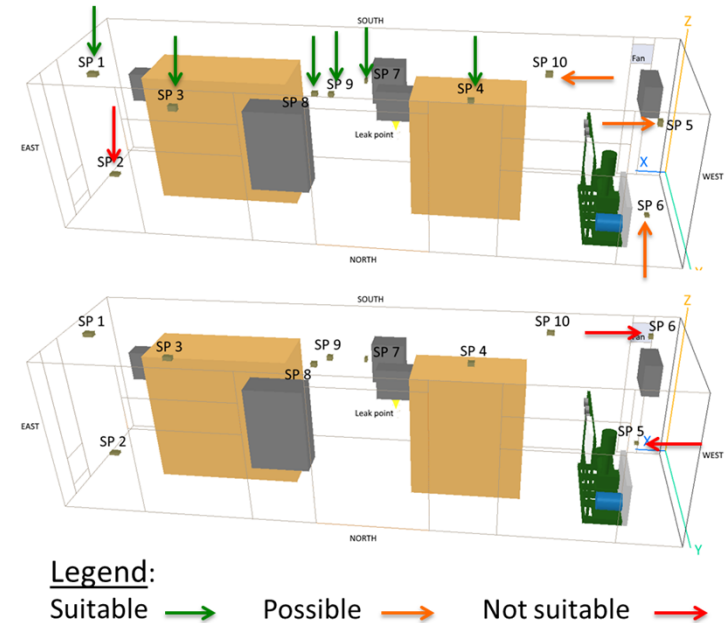

H₂ sensors are mandated by NFPA 2 and IFC, but without guidance on deployment. Understanding hydrogen plume behavior will guide sensor placement for optimized safety. Preliminary Sensor Placement Guidance will be presented at the 2019 ICHS (AVT, NREL and JRC)

Accomplishments and Progress: (HyWAM)

Analyzer Upgrades and Advancements (FY 18)

- NREL HyWAM System
 - Modular design, each with 8 or more H₂ sampling points
 - Active monitoring tool to alleviate LH₂ setbacks (NFPA)
 - Dedicated sensors ($\tau_{90} \approx 300$ ms)
 - Research and Demonstration System at NREL
 - NREL Provisional Prov 18-28: Wide Area Monitor for Hydrogen Releases within Hydrogen Facilities (HyWAM)
 - R&D tool for release modelling and site safety monitor

FY 2019 Planned Activity

- Elucidate LH₂ Release Behavior
- Strategic Partnerships to support HyWAM deployment
 - KWJ and First Element (TCF proposal)
 - HSL (NREL NDA 19-1382, 2019 ICHS)
 - Multiple WPs (PRSLHY)
 - Hardware demonstration: March 25-30, 2019
 - Releases start spring/summer
 - Outcome of HySafe
 - CGA/CHART (Ignited Releases)
 - National Laboratories (SNL, LLNL)

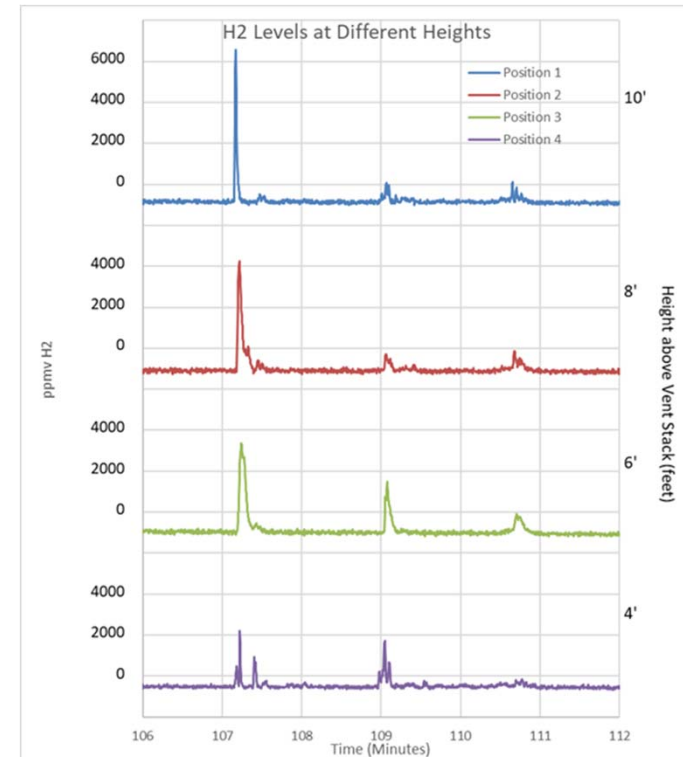

Sensor responses from 4 of 8 measurement points (NREL Research and Demonstration HyWAM)

Hydrogen Wide Area Monitoring (HyWAM)

The quantitative spatial and temporal 3-dimensional profiling of hydrogen releases (planned and unintentional)

Accomplishments and Progress: Internships within the NREL Sensor Laboratory

On-going mentoring of undergraduate scientists and engineers within the NREL Sensor Laboratory

Student Interns within the NREL Sensor Laboratory

- Mutually beneficial
- Real-world research experience in H₂
- Assigned as “technical lead” on a topical project
 - Interactions with clients
 - Allowed to present on their own work
 - Good publication record (co-authorship on talks, reports, and journal articles)
- FY18-19 interns (Hannah Wright, Tashi Wischmeyer)
- Successful post-graduation careers
 - Several have hired on at NREL



Former Sensor Laboratory Interns
M. Bubar, H. Wright, K. Schmidt, I. Bloomfield

**An NREL Internship provides real world experience in renewable energy.
Several Sensor Laboratory Interns have been hired by NREL**

Accomplishments and Progress: Responses to Previous Year Reviewers' Comments

Overall the comments from the 2018 AMR were positive and recognized the importance and contributions of the NREL Sensor Laboratory to the DOE Hydrogen program

Project Strengths: Project strengths include relevant accomplishments, a strong collaborative network, sustained engagement of the technical community, and a good progression of findings to practical scale, even with funding reductions in fiscal year 2017.

Project Strengths: The PI is clearly a national leader in sensor technologies—leading the effort to publish a TIR for SAE is a major achievement. The HyWAM work looks very promising.

Accomplishments and Progress: Responses to Previous Year Reviewers' Comments

Project Weaknesses: There was no data management plan. There is no information provided to facilitate access to the research.

Recommendations for Additions/Deletions to Project Scope: It is recommended that the team consider adding a method for accessing the project data, reports, presentations, draft plans, etc. The team should ensure these can be readily accessed by stakeholders.

- As noted in the introduction, the “traditional” mission of the NREL sensor laboratory was to provide confidential assessment of sensor performance. This often precluded open dissemination of data, and often presentation of data had, by necessity, to be sanitized.
- The emerging role of the NREL sensor laboratory is to utilize hydrogen detection support the elucidation of hydrogen release behavior, especially with regards to LH2 releases. To do this, we have entered into strategic partnerships, with HSL in the United Kingdom, private companies, and other national laboratories. The data from the HSL releases will be supported through the FCH JU PRSLHY program, and the data will be made available to the hydrogen community. HSL and NREL are already discussing this in the proposed deployment plan currently under development. Other partnerships include LLNL / SNL in which the data will be openly shared among partners.

Accomplishments and Progress: Responses to Previous Year Reviewers' Comments

Project Weaknesses: Some of the sensor evaluation work seems to be something that an entity such as Underwriters Laboratories (UL) could perform and, therefore, seems not to require DOE funding. Sensor manufacturers should seek a listing for their products to a published standard.

- First off, it should be noted that the NREL Sensor Laboratory does NOT certify sensors, and that our activity supports sensor RD&D. For the past several years, our evaluations have focused on working with sensor developers on assessing the performance of their sensing technology. Some of this activity was through the SBV program (implemented explicitly to provide small businesses access to resources available with the National Laboratories). The cost and complexity of certification is an identified gap (2017 JRC – NREL – FCH JU Hydrogen Sensor Workshop).
- Performance testing on commercial sensors is now more focused on qualifying sensors for a specific application (which is not necessarily covered in standards), such as HyWAM or internal RD&D.
- Although performance testing remains a core capability of the NREL Sensor Laboratory, it is at a lower activity level than in past years.

Collaborations: Private and Government Partnerships

Performance & Qualification (Safety)

Sensing Element (Sensor) Development

- Element One, Inc. (subcontract)
- KWJ, Engineering (SBV, SBIR)
- Panasonic (NDA)
- Nitto (NDA)

Infrastructure Support/Safety

- AVT (subcontract),
- KWJ (TCF, NDA on HyWAM)
- First Element (NDA, TCF)
- Shell
- CGA/Chart, Inc.

Vehicle Support

- Ford Motor Company (NDA)
- JARI (through the SAE FCSC)

New Markets

- HyWAM Development and Applications
 - CRADA (Toyota)
 - CGA/CHART (private)
 - LLNL/SNL (AOP)
 - HSL

Process Monitoring and Methods

Infrastructure Support

- NFPA 2 H₂ Storage Safety Task Group

Vehicle Support

- SAE Fuel Cell Standards Committee

Government Partnerships

- DOT/NHTSA (IAG) with TCa/ECCCa
- Joint Research Centre, Clean Energy Group
- HSL (LH₂ behavior/HyWAM)
- Ca Go Biz (DOE-California CRADA: California Hydrogen Research Consortium)

The NREL Sensor Laboratory

A resource to the H₂ community

- Infrastructure, vehicle, and new markets
- Sensor developers and end-users
- Formal and informal agreements
- Available for WFO

Remaining Challenges and Barriers

Hydrogen Sensors for Safety Applications

- **Sensor Placement:** Sensor placement strategies are primarily by intuition. Guidance documents are lacking. Cost-effective sensor technology is necessary for large facilities (e.g., H₂@scale); validated alternative strategies may be needed. (Identified as top research priority at the HySafe RPW)
- **Low maintenance sensors/lifetime (cost of ownership):** Sensor maintenance (calibration, replacement, and even out-of-the box out-of-spec performance) remains an issue. Validated ALT technology for lifetime predictions does not exist.
- **Active Monitoring for Enhanced Safety/HyWAM:** An economical HyWAM with the necessary metrological characteristics does not exist, especially for routine use. Active monitoring, coupled with CFD may be required to economically meet compliance requirements of NFPA 2
- **Complex Standards Requirements:** Strategies for meeting safety requirements require complex testing and validation; standards and safety strategies are not internationally harmonized

Process Control/FQ (“specialized” applications):

- **Metrologic performance:** Emerging applications have unique and challenging analytical requirements (detection limits, harsh environments). J2719 undergoing revision (to be harmonized with the ISO FQ standard)

Proposed Future Work: Hydrogen Sensors and the NREL Sensor Laboratory

- **Hydrogen Wide Area Monitoring (HyWAM)**

(Quantitative 3-dimensional Temporal and Spatial Profiling of Hydrogen Releases)

- Applicable to LH2 and GH2; indoor and out door activity; Planned releases (Research HyWAM) and as a Safety Tool for monitoring of unintentional releases (Commercial HyWAM)
- Integration into QRA for enhanced safety
- Stand-off strategies vs. Point Sensors

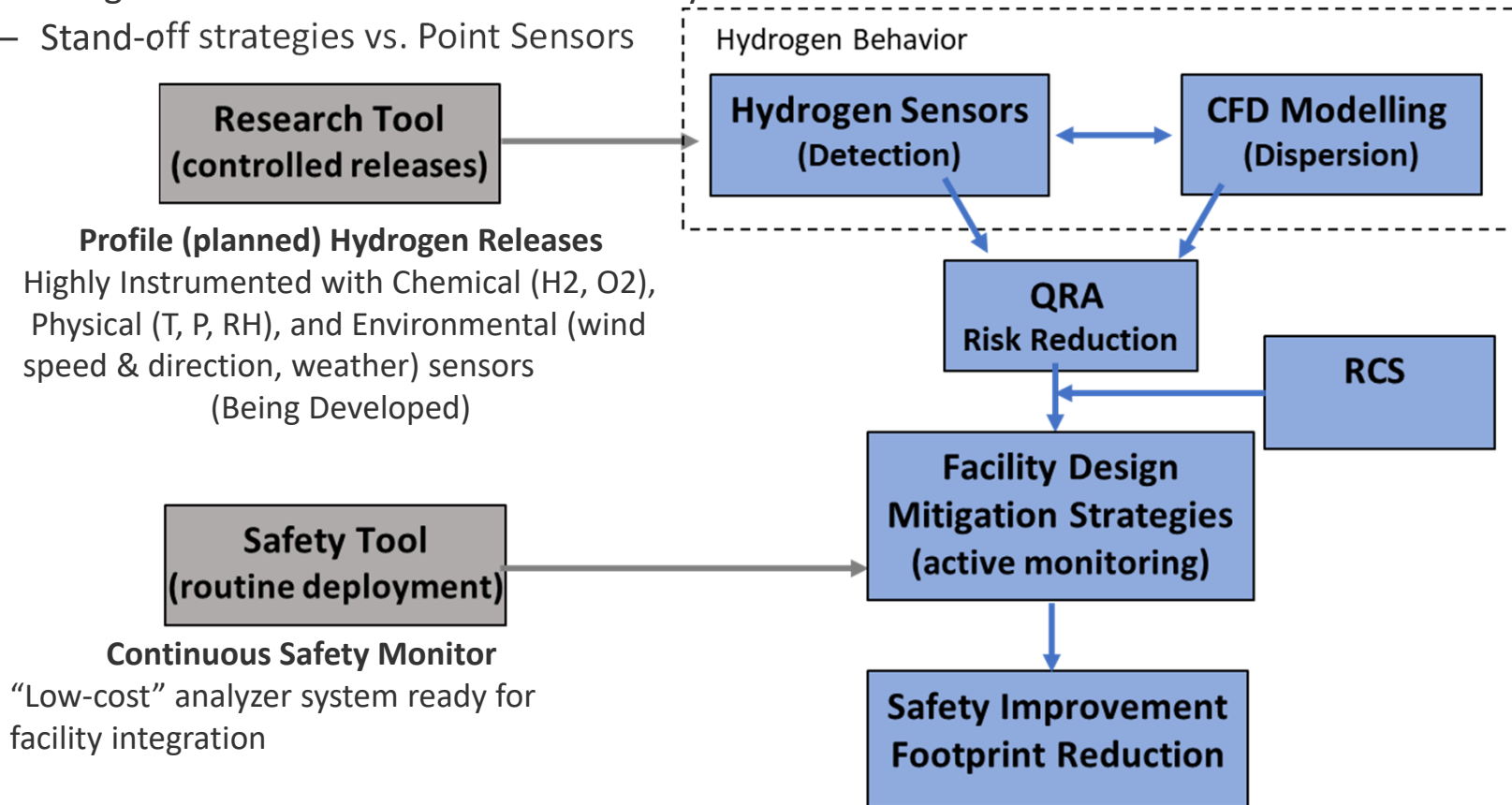

Active Monitoring has been identified as a potential mitigation strategy to alleviate NFPA 2 LH2 setback distances

Proposed Future Work: California Hydrogen Research Consortium (Project ID H2041) J. Kurtz, S. Sprik, M. Peters, W. Buttner, S. Onorato

Task 3 (HCD): With M. Peters, M. Koleva, J. Rodgers, C. Kreutzer

Task 3: H₂ Contaminant Detector 24 months, \$300k DOE, \$100k CA	Complete near real-time compliance verification to the J2719 requirements of in-line hydrogen quality detectors prior to validation at retail hydrogen stations.
---	--

In Progress

- Leverage previously funded HCD work
- Initiated assessment of possible HCD and selection criteria (e.g., matrix)
- Initiated interface experimental setup and risk review



Prototype image of HCD interface for initial verification of HCD operation
Source: NREL

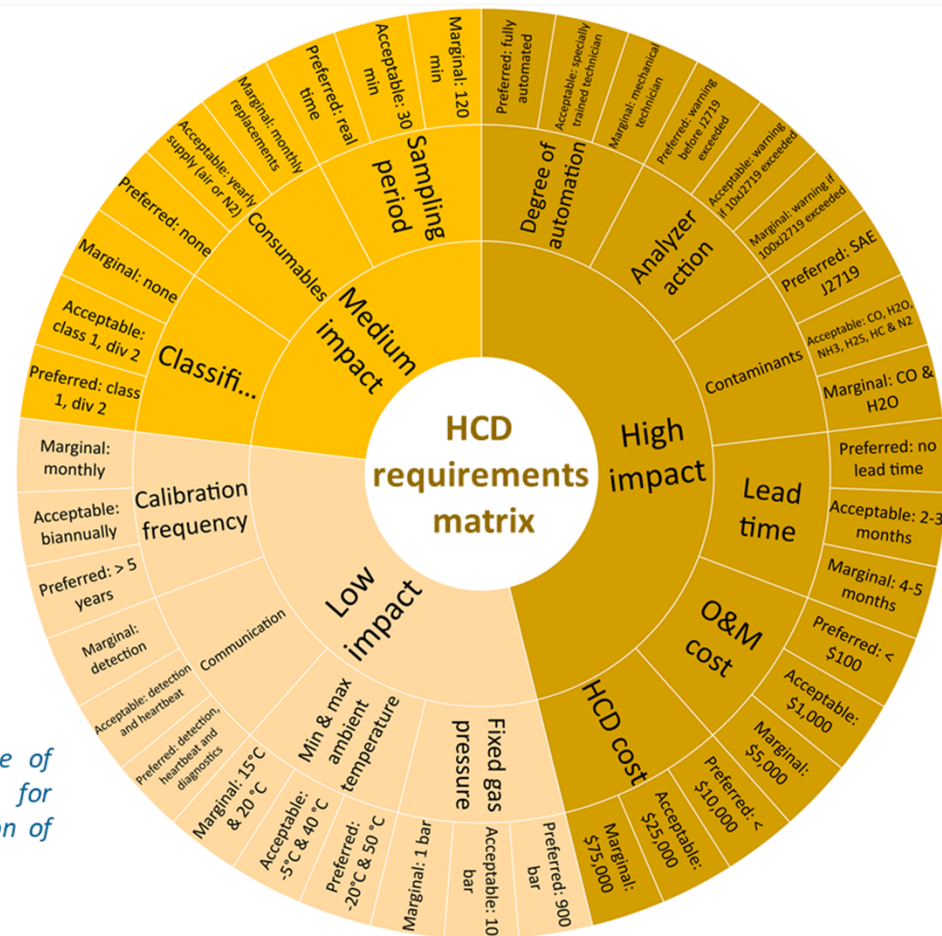

Technology Transfer Activities

- **NREL Provisional Patent PROV/17-94A** “Interface for High Pressure Dispensers”, W. Buttner, K. Harrison (October 30, 2018)
 - A universal low-pressure interface to any commercial/developing HCD.
- **NREL Provisional Patent PROV/18-28** “Hydrogen Wide Area Monitor”, W. Buttner, (December 17, 2018).
 - Basis for a successful Technology Commercialization Proposal with industrial partners (KWJ, First Element) to develop a effective HyWAM based upon NREL Technology
- **NREL Record of Invention ROI-19-25** “Collection Probe for Gas Analysis of Hydrogen Fuel Cell Exhaust”, W. Buttner, T. Wischmeyer (December 13, 2018)
- **NREL Record of Invention ROI-19-13** “Microfluidic Measurement of Multiple Gaseous Constituents in Hydrogen Systems” W. Buttner/NREL, J. Stetter/KWJ (November 13, 2018) Topic for SBIR Proposal
- **Small Business Voucher** projects to facilitate technology development from U.S. small business.
 - KWJ: Advanced Characterization of Printed Hydrogen Sensors for Fuel Cell and Vehicle Applications
 - Element One (CRADA 16-613): Development and Testing of Low-Cost Hydrogen Leak Detection

Summary

Relevance: Sensors are a critical hydrogen safety element and will facilitate the safe implementation of the hydrogen infrastructure.

Approach: NREL Sensor Laboratory tests and verifies sensor performance for manufacturers, developers, end-users, regulatory agencies and SDOs/CDOs.

Accomplishments and Progress: NREL's R&D accomplishments have supported developers, industry, and SDOs by providing independent third party assessment of performance.

Collaborations: Collaboration with other laboratories (JRC, universities, private industry) has leveraged NREL's success in advancing hydrogen safety sensors and process control.

Proposed Future Work: NREL will support hydrogen deployment and the proper use of hydrogen sensors. NREL will support the development of improved methods to verify fuel quality. NREL will continue to work with SDOs to revise documents, when required.

Summary: Advancement from 2018 of on-going projects and activity

Project/Activity	FY 18 Status	FY 19 Advancements
SAE TIR J3089	Completed draft TIR document under the auspices of the SAE Fuel Cell Standard Committee and submitted for ballot	Passed ballot with comments. Revised and passed affirmation ballot. Published in October 2018 (https://saemobilus.sae.org/content/j3089_201810)
HyWAM (Outdoor Applications)	Upgraded HyWAM system, IJHE paper on initial LH2 releases, ROI, active NFPA 2 subgroup participation, expanded applications, new partners (industrial, gov.)	On-site deployment of NREL HyWAM (GH2), active collaboration to deploy during planned LH2 releases (HSL, CGA/Chart, LLNL/SNL). HyWAM test plan complete for HSL LH2 Release. Site visits to HSL, Chart, LLNL
HyWAM (Indoor, GH2/He)	Completed the HyWAM instrumentation of test facility with the NREL HyWAM, ran He releases. CFD modelling performed by AVT (subcontract) and JRC	Empirical validation of CFD indoor release models by NREL HyWAM. Preliminary sensor placement and guidance document under development (2019 ICHS Paper)
FCEV Exhaust Analyzer, support of GTR 13	IAG with DOT (AIG 17-2046) through Sept 30, 2018 to deploy and validate the NREL Exhaust Analyzer. Developed and tested probe on FCEV, completed preliminary testing.	Under DOT guidance, worked with TC and ECCC. Revised probe design and tested on FCEV for compatibility with ECCC test facility. Field Test at TC/ECCC planned for 2019.
Sensor Testing and Evaluation	General testing in support of deployment, primarily under AOP and through SBV program	Performance evaluation remains a core capability of the NREL Sensor Lab, but more focused under NDAs and TSAs with sensor developers and end-users & support HyWAM.
CDO/SDO Committees	Completed SAE TIR J3089. Preliminary pre-normative research on hydrogen release behavior (especially LH2), on-going verification technology development	Continued participation on SAE standards committee (e.g., revised J2719--Fuel Quality); active on NFPA 2 Storage Task Group,
FQ Verification		Technical Lead on HCD Task within the auspices of a NREL-DOE-CA CRADA ; Provisional Patent on Interface and ROI of HCD analyzer. J2719 (FQ) is undergoing 5-year revision.

Much of the NREL Sensor laboratory FY19 activity is ongoing and naturally builds off the past work

Thank You

www.nrel.gov

Publication Number

NREL is a national laboratory of the U.S. Department of Energy, Office of Energy Efficiency and Renewable Energy, operated by the Alliance for Sustainable Energy, LLC.



Technical Back-Up Slides

(Include this “divider” slide if you are including back-up technical slides [maximum of five]. These back-up technical slides will be available for your presentation and will be included in Web PDF files released to the public.)

“Research” vs. “Commercial” HyWAM

“Research HyWAM”

- Specialized apparatus primarily for planned releases
 - HSL, CGA/Chart, LLNL/SNL, Linde, NREL and other labs,
 - Empirical data to support modelling studies
- Highly Instrumented array of support structures
 - Chemical (H₂, O₂, other?)
 - Physical (T, RH, P)
 - Environmental (wind speed & direction, radiance)
- Identify “controlling factors” plume dispersion
 - Environment parameters
 - Facility impacts
 - Release conditions
 - Support model development and validation
- Hardware validation
 - Sensor types (TC is baseline, but others)
 - (e.g., validate emerging sensors—fiber optic)
 - Other WAM Approaches (standoff methods, TBD)
 - Guide commercial HyWAM design and operation



“Commercial” HyWAM Applications/NEED

LH2 Storage at commercial fueling stations

- Means to increase site storage capacity
- NFPA 2 LH2 Setback Distance 75 feet
- Mitigation strategies include site monitoring (HyWAM)
- Also good for GH2

Commercial HyWAM

- Requirements
 - Continuous unattended operation, interfaced to facility control system, low-cost
- Gaps
 - Commercial HyWAM system does not exist
 - Deployment (placement) guidance does not exist
- Addressing Gaps
 - Deploy Research HyWAM to identify key parameters and get dispersion data
 - CGA?, Internal NREL Operations, First Element?
 - Data to be shared with SNL, JRC, others for modelling
 - Models will provide deployment guidance
 - Develop Hardware
 - Sensor types and number, and location
 - Partners: Fueling Facility and Instrument Manufacturer

