



Energy Materials Network  
U.S. Department of Energy



**HydroGEN**  
Advanced Water Splitting Materials

# A New Paradigm for Materials Discovery and Development for Lower Temperature and Isothermal Thermochemical H<sub>2</sub> Production

Jonathan Scheffe  
University of Florida  
5/29/2020

Project ID #  
P195

This presentation does not contain any proprietary, confidential, or otherwise restricted information





# Project Overview

## Project Partners

PI: Prof. Jonathan Scheffe, University of Florida

Co-PI: Prof. Juan C. Nino, University of Florida

Co-PI: Prof. Simon Phillpot, University of Florida

## Project Vision

We propose an innovative materials design approach that combines computational and experimental efforts towards the development and demonstration of novel materials for efficient solar thermochemical hydrogen (STCH) production under isothermal operation.

## Project Impact

Provide a pathway resulting in the scalable and efficient ( $\eta_{\text{solar-to-fuel}} > 26\%$ ) STH production, ultimately enabling DOE target of less than \$2/gge.

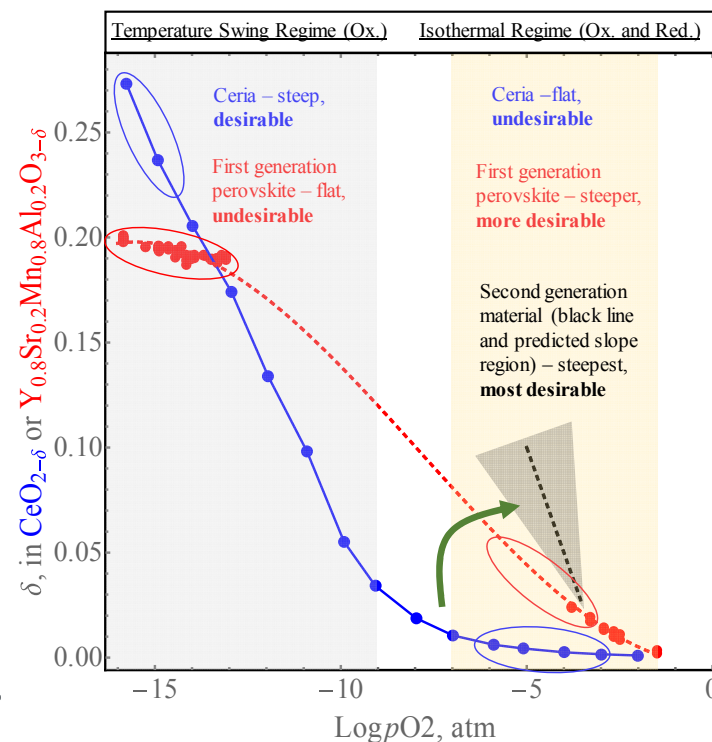
\* this amount does not cover support for HydroGEN resources leveraged by the project (which is provided separately by DOE)



# Approach: Summary

## Project Motivation

- Record  $\eta = 6\%$  measured by Steinfeld et al. Major irreversibility  $T_{\text{swing}}$  requires 63%  $Q_{\text{in}}$ . Solid phase heat recuperation difficult.
- Davidson et al. report gas phase heat recuperation of 95% for isothermal cycle. Overall lower  $\eta$  using same material ( $\text{CeO}_2$ )
- Can we couple computation and synthesis to develop more optimal material compositions and structures that operate isothermally?

## Barriers

- Computational accuracy coupled with high throughput
- Material stability and kinetics – phase stability and redox capability. Does it work?
- Scale-up synthesis and stability – porous structure synthesis and characterization with simulator and laser heating

## Key Impact

Metric	State of the Art	Expected Advance
Parameter 1	$\text{CeO}_{2-\delta}$	Perovskites beyond Manganates
Parameter 2	Performance ( $\propto \eta$ ) $< 7.5\text{E}10^{-5}$	Performance ( $\propto \eta$ ) $> 7.5\text{E}10^{-5}$
Parameter 3	Powdered materials	Ceramic foams to improve rxn. rates & radiative transfer

## Partnerships

**Simon Phillpot** – UF MSE - density functional theory (DFT) to address critical problems in materials discovery. Defect energetics and kinetics in complex oxides.

**Juan Nino** – UF MSE – ceramic processing and characterization. Fluorites, pyrochlores, perovskites, spinels for fuel cells, catalyst supports, semiconductor detectors, etc.



# Background: Efficiency of STH Cycles

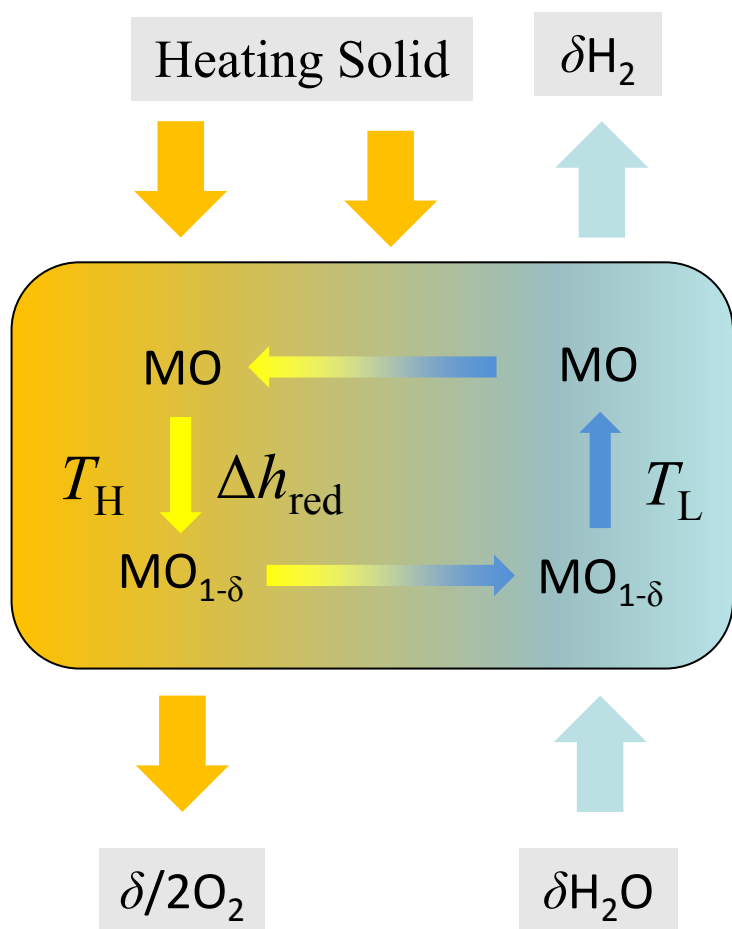

Large for  $T_{\text{swing}}$  cycle,  $T_H > T_L$

$$\text{Heating Solid Reactants} = \int_{T_L}^{T_H} c_{p,\text{ox}} dT$$

+

$$\text{Endothermic Reduction} = \Delta h_{\text{red}} \delta$$

+

Large for **isothermal** cycle,  $T_H = T_L$

$$\text{Heating Fluid Reactants} = \dot{n}_{\text{H}_2\text{O}} \Delta h_{\text{H}_2\text{O}} \Big|_{298\text{K} \rightarrow T_L}$$

$$Q_{\text{in}} = Q_{\text{solar}} \eta_{\text{abs}}$$

Heating Fluid Reactants

$$\eta_{\text{solar-to-H}_2} = \frac{\delta HHV_{\text{H}_2}}{Q_{\text{solar}} + E_{\text{penalty}}}$$



# Approach: Innovation

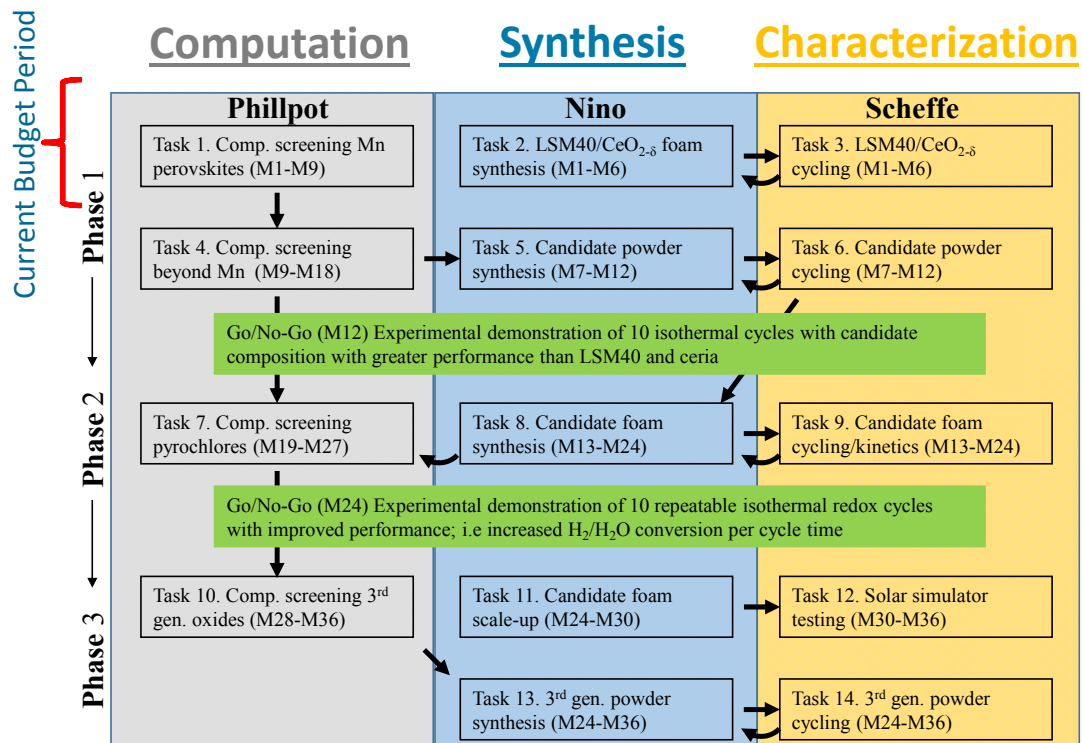
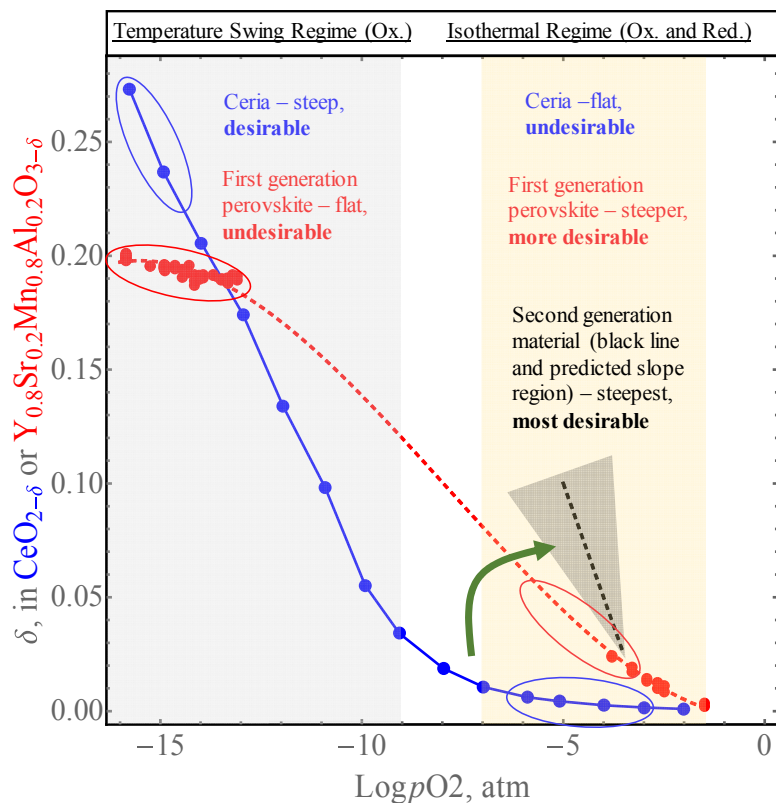

**Our Approach** - rather than focus on increasing  $\Delta s$ , use computation find the right combination of  $\Delta s$  and  $\Delta h$  computationally to improve **Performance** (slope) isothermally



# Relevance and Impact

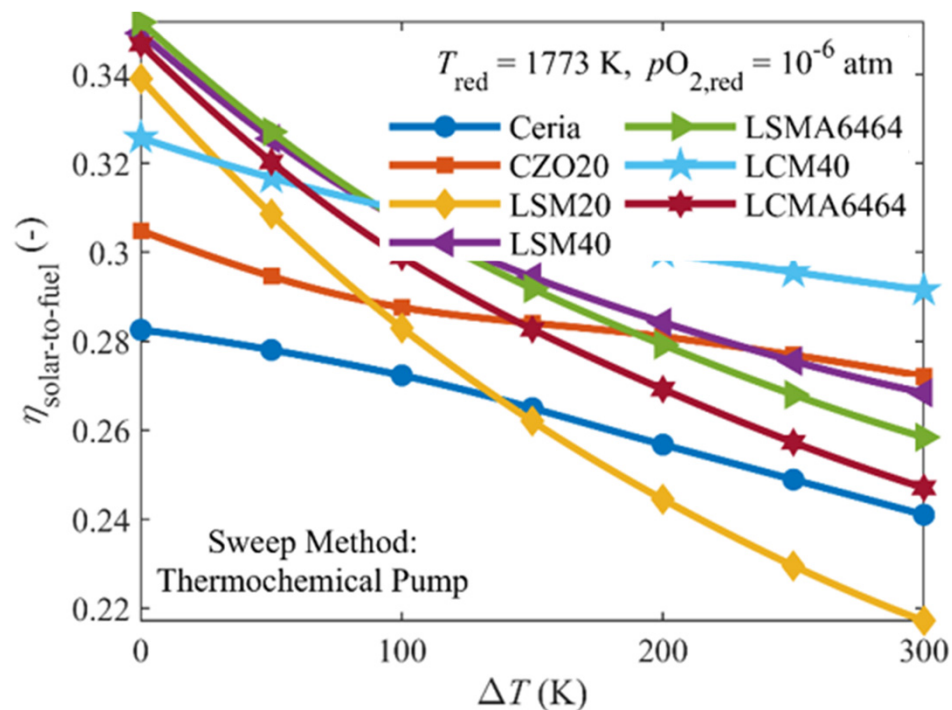
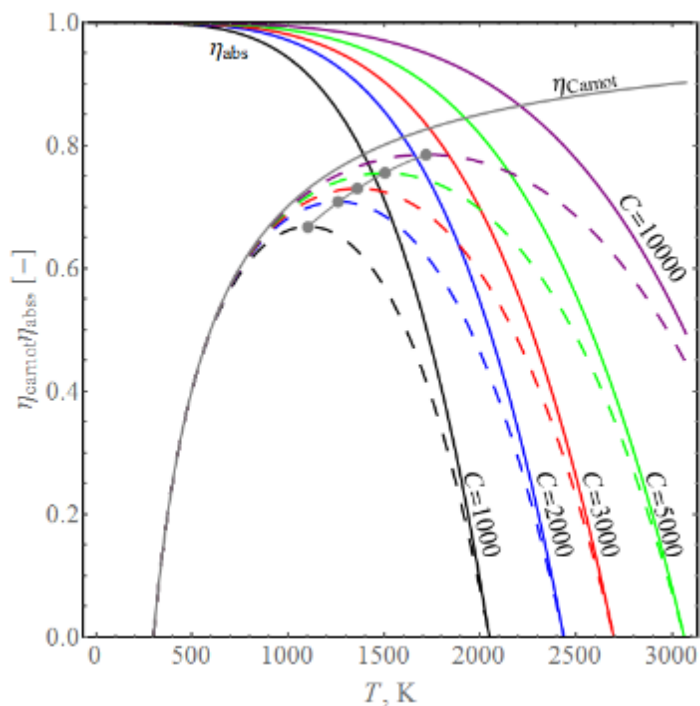

- ▶ Thermochemical pathways are capable of utilizing the entire solar spectrum, and as such provide a thermodynamically favorable pathway towards solar  $\text{H}_2$  production (left figure).
- ▶ By decreasing operation temperature and temperature swings, our technology is well suited to be scaled and withstand harsh conditions that limit lifetime of reacting materials and reactors.
- ▶ Established materials already show a viable pathway to improve  $\eta$  beyond ceria (right figure), and when coupled with new advancements from computation we expect even more improvement.  $\eta$  is the single largest factor affecting the DOE's mission to sustainably produce  $\text{H}_2$  for  $<\$2/\text{kg}$ .
- ▶ This work aligns nicely with several of the DOE  $\text{H}_2$  consortium nodes: computation, experimentation with high flux radiation to simulate concentrating solar and fundamental insights.





# Accomplishments: Budget Period 1 Phase 1

- **Task 1, Milestone 1.2.1 (Q3): Identification of stable B-site and A-site substitutions that lead to formation energies only slightly greater than the target value of 2.5eV.**
- We identified the computational parameters that meet the precision needs of the high-throughput screening of cubic structure (space group Pm-3m), orthorhombic structure (Pnma), trigonal structure (R-3c), hexagonal structure (P63cm) and cubic structure (Ia3) for the lowest computational cost.
- The appropriate smallest values are KPOINTS = 64 (4 x 4 x 4) for cubic structures and 48(4 x 4 x3) for other structures; ENCUT = 400 eV; and ETOL = 10<sup>-4</sup> eV.
- These settings save considerable computational cost and offer reliable calculations. For the simple case of LaMnO<sub>3</sub>, these setting show that the orthorhombic structure has the lowest energy.

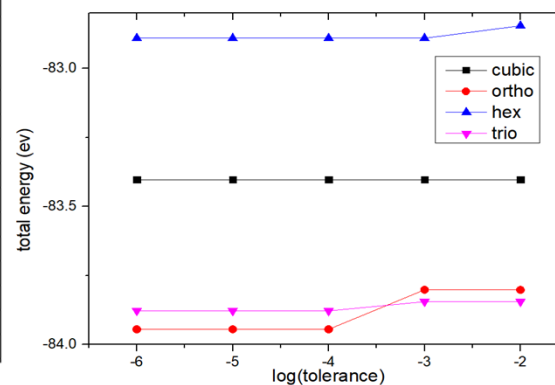
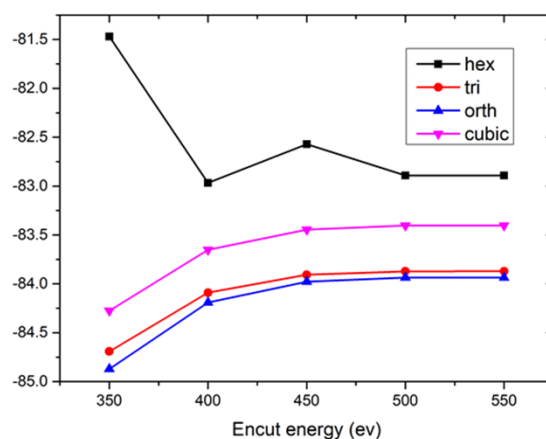
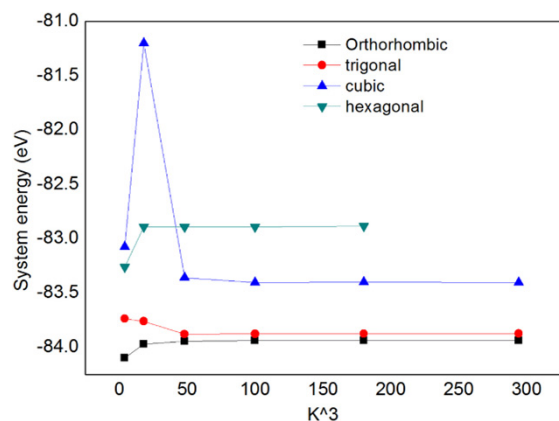

(left) k-point test for different structures in LaMnO<sub>3</sub> (center) Energy cut off test for different structures in LaMnO<sub>3</sub> (right) energy tolerance test for different structures in LaMnO<sub>3</sub>



# Accomplishments: Budget Period 1 Phase 1

- **Task 1, Milestone 1.2.1 (Q3): Identification of stable B-site and A-site substitutions that lead to formation energies only slightly greater than the target value of 2.5eV.**
- We have performed test calculations with DFT+U on Mn sites, to see if it has an effect on the energetics.
- This had the effect of reducing the energy difference between the orthorhombic and trigonal phases, though the orthorhombic phase remains the lowest energy structure.
- The excess energy of the four structures are above the orthorhombic phase and show that the predictions with the regular and ultrasoft oxygen potential are essentially the same.

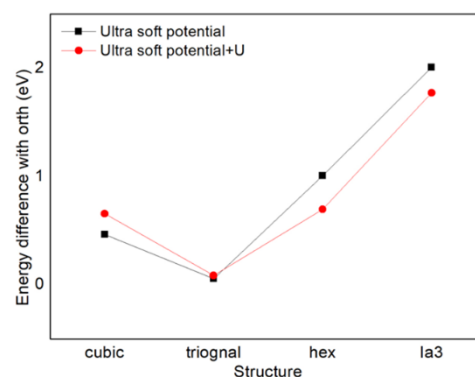
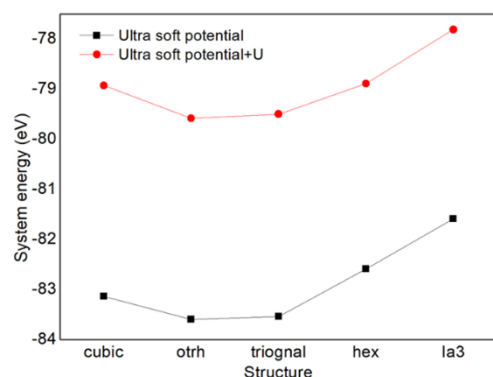

(left) total energy calculations of LaMnO<sub>3</sub> structures with DFT+U method and standard DFT (right) energy difference between orthorhombic structure and other structures in LaMnO<sub>3</sub>.





# Accomplishments: Budget Period 1 Phase 1

- **Task 2, Milestone 2.2.1 (Q2): Synthesis of ceria and LSM40 foams with overall porosities greater than 60% using the direct foaming method.**
- Direct foaming method incorporates air into a suspension which then leads to trapped air upon setting, forming pores in the ceramic. Air is incorporated into the suspension either by an external gas phase or by in situ gas evolution.
- Three successful samples have been produced that are greater than 1 g, meeting the requirements for testing at this stage.
- To the right are optical images of two different samples. The foams look to possess an open-celled structure with few pores that are overly large. These samples will be shaped to fit in the reactor tube for testing.

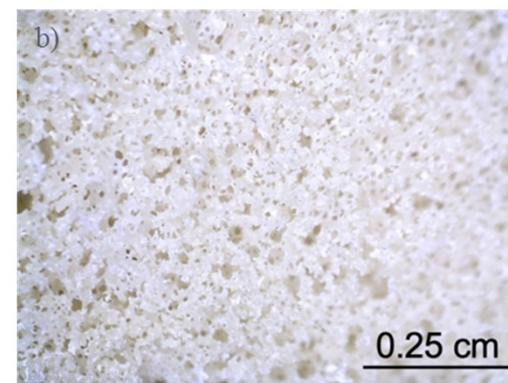
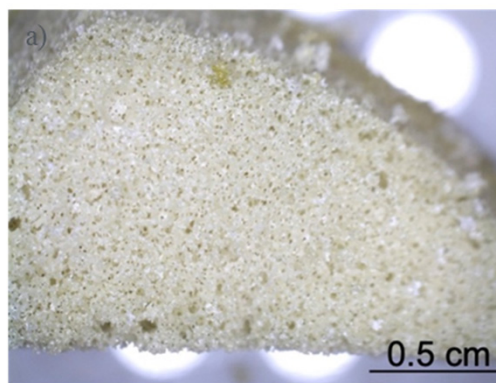
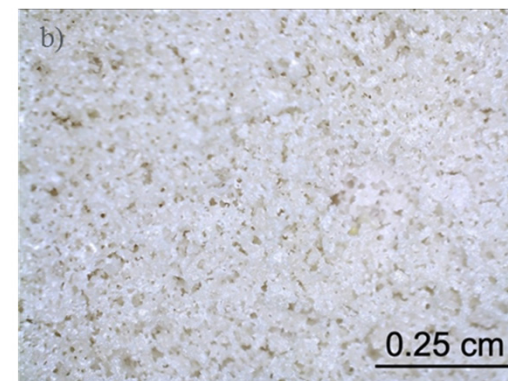
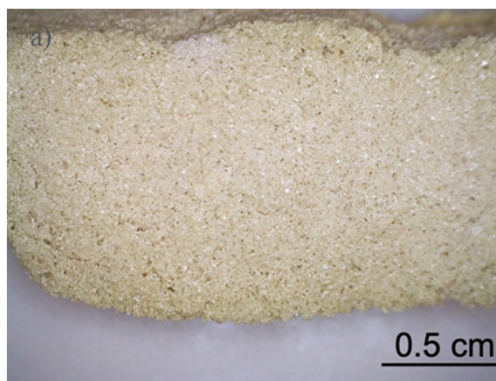



# Accomplishments: Budget Period 1 Phase 1

- **Task 3, Milestone 3.2.1 (Q2):** Demonstration of ten redox cycles of LSM40 and  $\text{CeO}_{2-\delta}$  under optimal reaction conditions, between 1200 °C and 1400 °C.
- **Task 3, Milestone 3.2.2 (Q2):** Demonstrating higher performance using LSM40.
- Experimental setup has been validated using LSM40 and  $\text{CeO}_{2-\delta}$  powders.
- Below is  $\text{H}_2$  production and consumption, corresponding  $\text{H}_2\text{O}$  input, and temperature profile of ceria during isothermal cycling at 1400 °C.

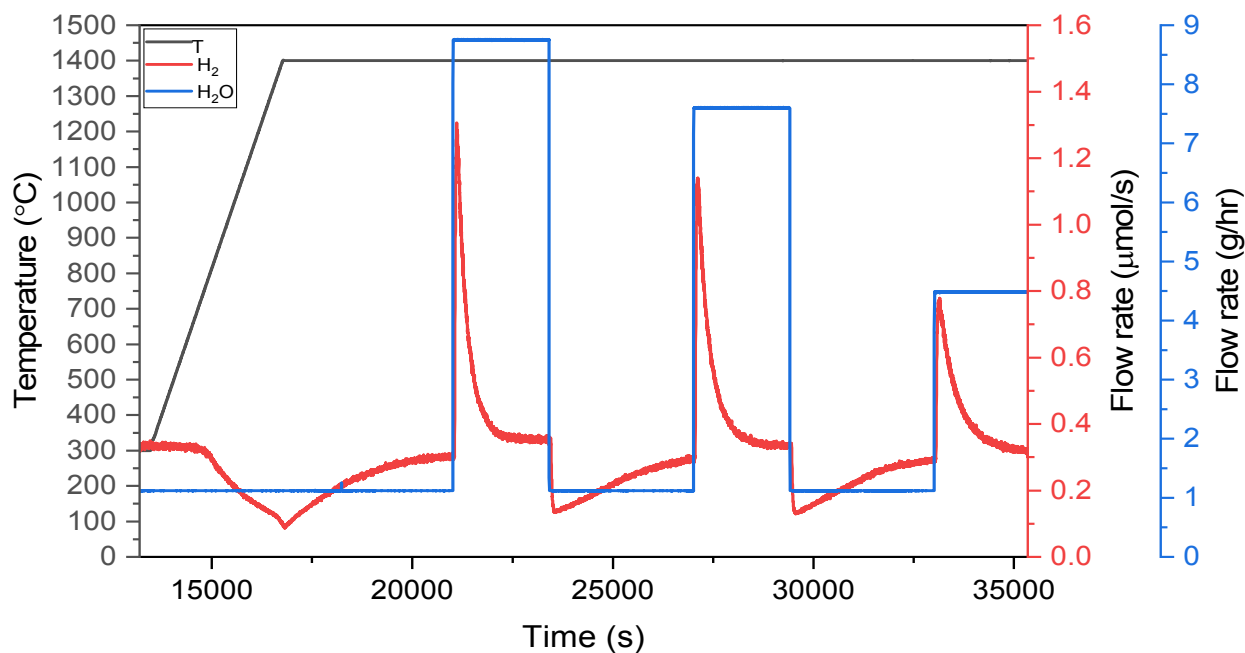



# Accomplishments: Budget Period 1 Phase 1

- **Task 3, Milestone 3.2.1 (Q2):** Demonstration of ten redox cycles of LSM40 and  $\text{CeO}_{2-\delta}$  under optimal reaction conditions, between 1200 °C and 1400 °C.
- **Task 3, Milestone 3.2.2 (Q2):** Demonstrating higher performance using LSM40.
- Below is  $\text{H}_2$  production and consumption, corresponding  $\text{H}_2\text{O}$  input, and temperature profile of LSM40 during isothermal cycling at 1400 °C.

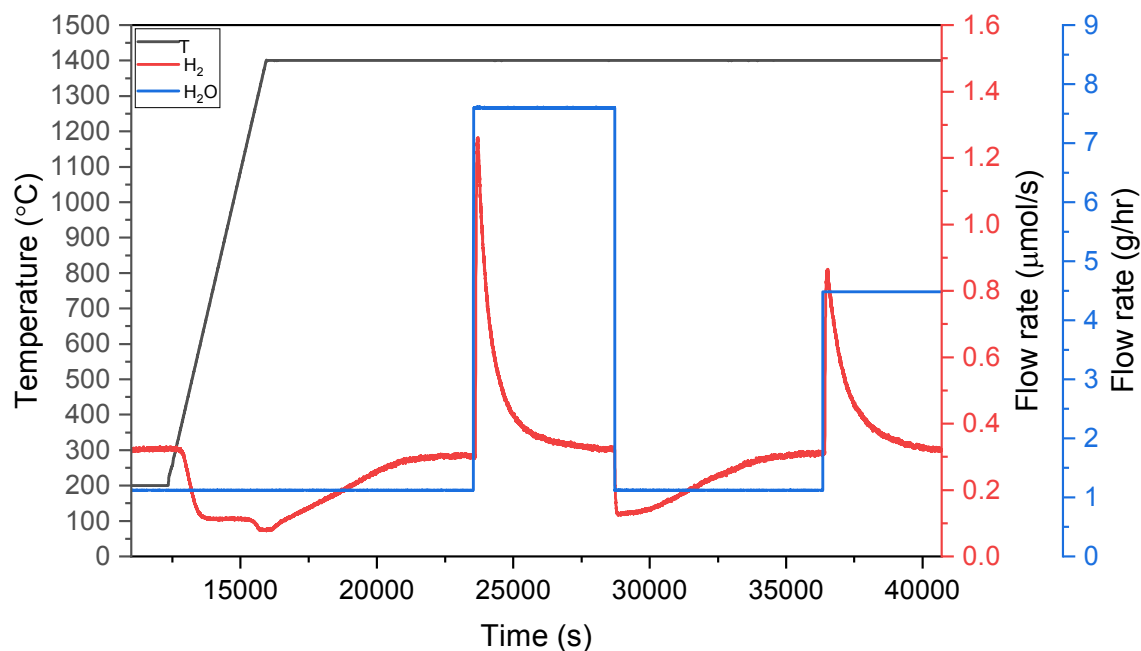



# Accomplishments: Budget Period 1 Phase 1

- **Task 3, Milestone 3.2.1 (Q2):** Demonstration of ten redox cycles of LSM40 and  $\text{CeO}_{2-\delta}$  under optimal reaction conditions, between 1200 °C and 1400 °C.
- **Task 3, Milestone 3.2.2 (Q2):** Demonstrating higher performance using LSM40.
- Below is summarized change nonstoichiometry of ceria (left) and LSM40 (right) vs.  $[\text{nH}_2\text{O}/\text{nH}_2]_{\text{in}}$  at 1300 °C, 1350 °C, and 1400 °C and comparison to thermodynamic predictions from the literature.

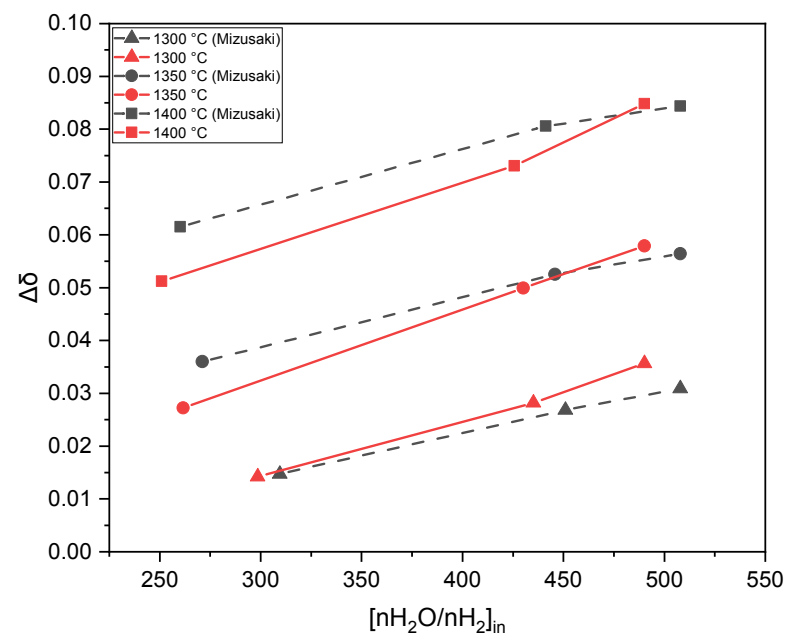
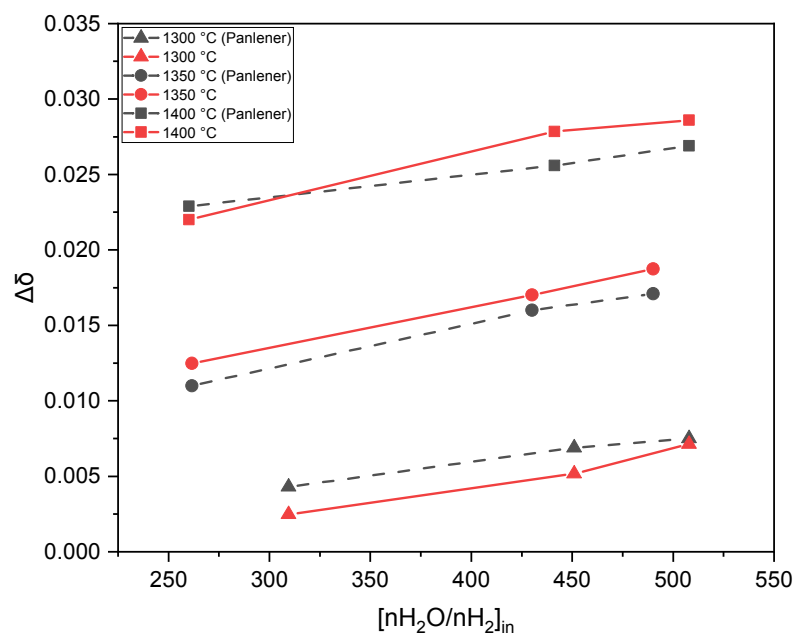

Panlener, R. J.; Blumenthal, R. N.; Garnier, J. E., Thermodynamic study of nonstoichiometric cerium dioxide. *Journal of Physics and Chemistry of Solids* 1975, 36, (11), 1213-1222.

Mizusaki, J. et. al., Oxygen nonstoichiometry and defect equilibrium in the perovskite-type oxides  $\text{La}_{1-x}\text{Sr}_x\text{MnO}_{3+d}$ . *Solid State Ionics* 2000, 129, (1-4), 163-177.



# Accomplishments: Budget Period 1 Phase 1

---

- **Outlook**
- **We are well positioned to Go/No-Go Decision Point by the end of Q4.**
- To summarize we have made major progress on Task 1 (computational screening), Task 2 (porous foam synthesis), and Task 3 (LSM40 and ceria characterization) and demonstrated the viability of our computational and experimental methods.
- Go/No-Go decision will be made based on demonstrating significant progress towards all milestones in BP1. Further, 10 near-isothermal cycles with identified compositions showing performance greater than LSM40 and ceria will be demonstrated.
- Based on our results and progress made toward achieving milestones during Q1 and Q2, we are confident that we are on track to achieve this milestone by Q4 at the end of this Budget Period.



## Collaboration: Effectiveness

---

- We have initiated a strong collaboration with the group of Dr. Stephan Lany at NREL's First Principles Materials Theory for Advanced Water Splitting Pathways. Dr. Phillipot's Ph.D. student is working closely with Dr. Anuj Goyal from Dr. Lany's team on standardizing the computational tools and efficiently working together on this project.
- After close coordination with Dr. Farid El Gabaly and Dr. Anthony McDaniel, we have identified the first set of samples and experiments to be performed at SNL's Near Ambient Pressure Electrochemical X-Ray Photoelectron Spectroscopy (E-XPS), part DOE's HydroGEN characterization node. These include: a) LSM powders as received, b) LSM powders after cycling, c) LSM powders quenched at operating conditions, and d) LSM foams.
- Since attending the benchmarking workshop in Fall 2019, we are working actively with the "2b" benchmarking/protocols team (under Dr. Ellen Stechel) on finalizing protocols for kinetic and thermodynamic evaluation of thermochemical redox materials.





# Proposed Future Work

- Currently we are about half-way through Q2 in BP1.
- Proposed work from Q2-Q4 involves the following
- Identification of the lowest energy structure of a number of AMnO3 systems, where A is a lanthanide or other element of interest.
- Testing the pylada-defects workflow tool (<https://github.com/pylada/pylada-defects>) for high throughput calculations of defect energies in the lowest energy structures identified by pylada.
- Fabricate LSM and candidate samples by the direct foaming method. Explore other synthesis techniques such as replica foam.
- Characterization of foams to calculate the size distribution of pores and overall porosity through pores, morphology and density.
- Begin testing ceria, LSM35 and candidate ceramic foams.
- Develop mathematical relationship for “Performance” benchmark to fairly compare isothermal materials.

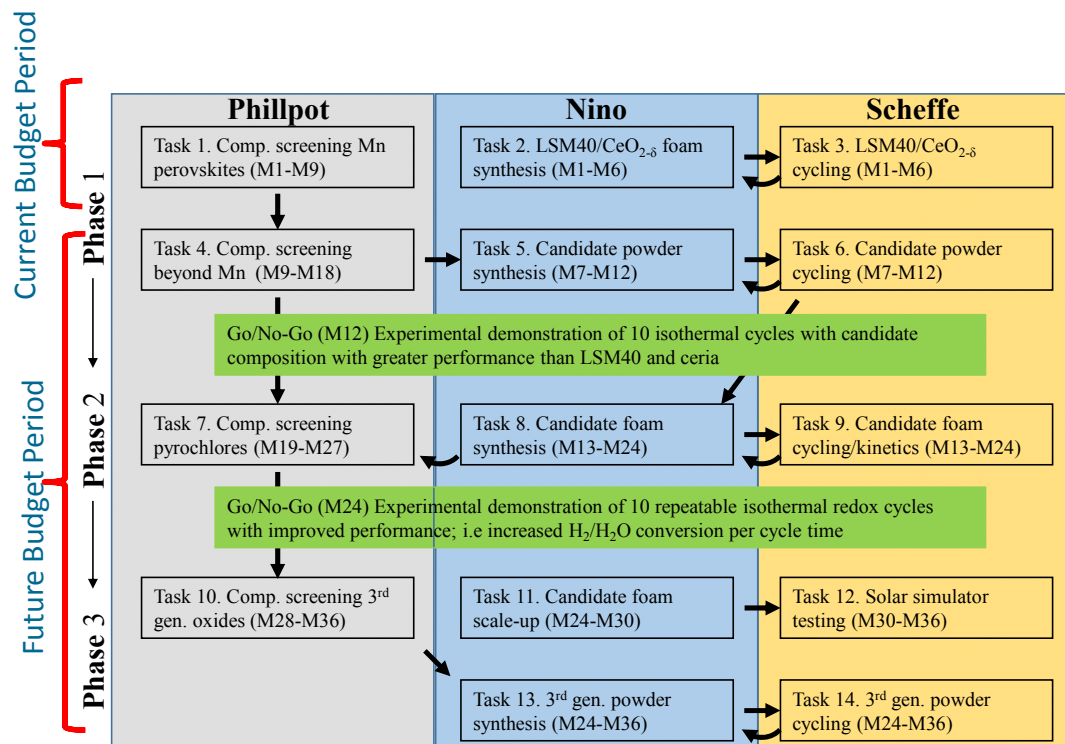

Total Project Value	\$1.25M (DOE+Cost Share) 20%
BP1 Value Cost Share %	\$.323M (DOE+Cost Share) 20%
BP1 Estimated Remaining Cost Share %	\$.0.16M (DOE+Cost Share) 20%





## Project Summary

---

- **We are well positioned to Go/No-Go Decision Point by the end of Q4.**
- Computational and experimental methods necessary for achieving all milestones during BP1 have been validated.
- Improved H<sub>2</sub> production/performance for LSM40 compared to ceria has been established using powder samples.
- Comparison and testing of samples for H<sub>2</sub> production will ensue using porous samples fabricated by the Nino Research Group.
- By the end of Q4 we aim to synthesize candidate materials beyond ceria and LSM40 and demonstrate greater isothermal performance in the temperature range 1200-1400 °C.