



# Los Alamos National Laboratory: Minority Serving Institutes Partnership

## DOE HFTO Annual Merit Review & Peer Evaluation Meeting May 6-9, 2024

Rod Borup (Program Manager) and  
Tommy Rockward (P.I.)

LAUR Requested

"This presentation does not contain any proprietary, confidential, or otherwise restricted information"

# Overview

## Timeline and Budget:

- Project start date: October 1, 2021
- Project end date: September 30, 2025
- Total budget: \$2.0M (\$500K/yr)
- FY23 Carry-over \$318K
- FY24 Expected \$500K

## Notable Partners:

- GM, LBL, & US Army  
DEVCOM
- LANL Director's office:  
URMPP
- NNSA MSIPP



## University Partners

U. Texas El Paso  
Morehouse  
Prairie View A&M U  
Tenn. St. Univ.  
Florida Int. Univ.  
Inter Amer. (P.R.)  
Southern Univ. (NO)  
Virginia State Univ.  
Navajo Tech Univ.  
Bay Mills CC  
Cankdeska Cikana  
CC  
Turtle Mountain CC  
Salish Kootenai  
Tuskegee University

U. Texas Rio Grande Valley  
Florida A&M University  
University of Arizona  
New Mexico State  
Southern University (BR)  
Southwestern Indian  
Polytechnical Institute  
New Mexico Tech  
Texas Tech University  
Miami-Dade College  
U. Texas San Antonio  
Nebraska Indian Community  
College  
Howard University  
N. Carolina A&T University

# Outline

- Project Goals and Approach
- Success Story
- Accomplishments via Existing Collaborations
  - Industry
  - National Labs
  - Universities
- Future Work
- Summary
- Acknowledgements

# Project Goals:

## Workforce Development for MSI Scholars:

- Relationship building **HFTO, LANL, Industry, and MSIs**
- Provide opportunities to MSIs & scholars to participate in and perform cutting-edge FC research
- Encourage MSI scholars to pursue advanced degrees and enter the 'H2 and FC Workforce'



# Approach:

## Recruit, Train and Retain:



From left to right, Los Alamos interns with the NTU partnership program Jonathon Chinana, Joel Yazzie, Nylana Murphy and Jasmine Charley. Los Alamos scientist and program principal investigator Tommy Rockward is at right.

### Harnessing potential from untapped talent

Los Alamos has worked with NTU for more than seven years to shape curricula through the NNSA's [Minority Serving Institution Partnership Program](#), a separate but related collaboration to align the university's STEM curriculum to match needs in the national security enterprise and prepare students for careers and advanced degrees. A range of outreach activities promote science and research to students to build a pipeline of students. Research opportunities are the final piece of the program, as students gain skills in manufacturing, characterizing and testing materials.



# Retention Leads to Success (shown FY23, Updated for FY24)

# New hire: LANL Staff



Robert Lazarin



Cortney Kreller



Rod Borup

- M.S. Mechanical Engineering (December 2022), University of Texas at El Paso
  - Thesis: ***“THE QUALIFICATION OF SEALABILITY AND CREEP RELAXATION OF ADDITIVELY MANUFACTURED ZYTEL GASKETS FOR PEM FUEL CELLS”***
  - Focus: Hydrogen Fuel Cells, Gaskets, Leak Rate, Creep Relaxation, Additive Manufacturing

Began Collaborating | Los Alamos NATIONAL LABORATORY | Graduated M.S. in ME in fall 2022

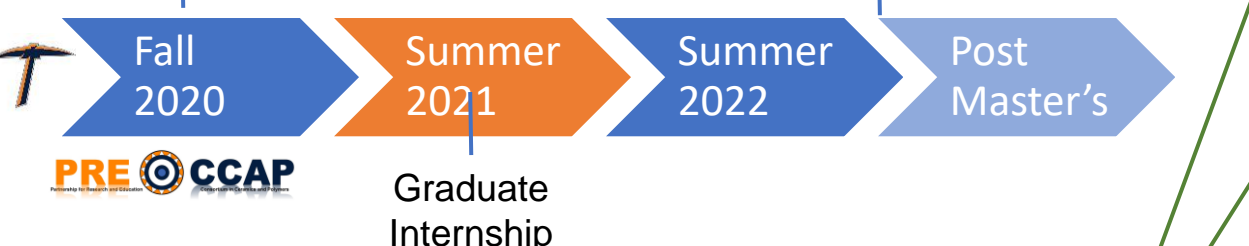

- Post-master's student at LANL (January 2023)
- Three focus areas: High Pressure PEMFC Gaskets, Electrochemical Corrosion of Metals, Novel Catalyst Manufacturing for PEMFC's

Development of High-Pressure FC Gaskets

Electrochemical Corrosion of Metals

Manufacturing Techniques for PEFC Electrodes

# Potential Impact: Developing the next generation workforce

# Collaboration and Coordination: LANL-MSIs Investigating Hydrogen Storage Materials



Rigobert Ybarra

Rigobert Ybarra: UT-Rio Grande Valley

- MS student graduating Spring '24
- Summer student at LANL '22 and '23
- Beginning Post-Master's at LANL Summer '24
- Synthesis and Characterization of graphite intercalation compounds (GICs).
- Study of GIC H<sub>2</sub> storage capabilities



Daniel Leonard  
LANL Staff Scientist



**Enhancement of Ni-Foam for Liquid Alkaline Water Electrolysis**

Rigobert Ybarra J., Dr. Daniel P. Leonard, Dr. Sandip Maurya | Materials Synthesis and Integrated Devices (MPA-11)

**Objectives:**

- The DOE goals stand to have cells perform below 0.2 A/cm<sup>2</sup> at 1.7 V per cell.
- Degradation testing for cells must last up to 1000 hours under corrosive conditions at 80-85 °C per cell.
- Current LAWE systems operate around 0.2-0.6 A/cm<sup>2</sup> @ 1.7 V.

**Introduction:**

- Liquid alkaline water electrolysis (LAWE) cells contain electrolyte that undergoes the oxygen evolution reaction (OER) and the hydrogen evolution reaction (HER).
- Due to the alkaline conditions present the use of highly abundant materials such as nickel are preferred over more susceptible metals.
- The modification of these cells at various points such as the electrodes with various deposition methods such as electrodeposition and sputtering.

**Discussion:**

- The HER and the OER occur at less than 0 volts and greater than 1.23 volts respectively on the Cathode and Anode of a operating cell.
- The use of nickel modified with iron alters the surface morphology of each electrode and has a direct effect with the OER activity.

**Conclusion:**

Through the use of different modification techniques ( sputtering and electrodeposition) the surface of a known commercial electrode have been modified. The method that was tested was able to increase performance of nickel based. Further investigation it can be said that with different alloys, or variations of the cathode and anode electrodes can yield varying results.

**Acknowledgment:**

Thanks to Daniel P. Leonard, Dr. Tommy Bookout, and Dr. Sandip Maurya. Along with everyone else that assisted me to be able to learn and conduct this team. This project was supported by the Department of Energy and Minority Serving Institutions Partnership Program (MSIPP) and JAMEMPOWERED. Special Thanks to Los Alamos National Lab.

Los Alamos National Laboratory, MSIPP, NNSA, Department of Energy

# Collaboration and Coordination: LANL-MSIs

## Analysis of MEA degradation compounds during CO<sub>2</sub> capture

- Create multiple MEA samples as well as the degradation compounds which include: 2-Oxazolidinone, N,N'-bis(2-hydroxyethyl)urea, N-(2-hydroxyethyl)ethylenediamine, and N-(2-hydroxyethyl)imidazolidin-2-one
- Use HPLC instrumentation to create an analytical method to quantify the degradation compounds in the MEA samples
- Use NMR instrumentation to analyze the CO<sub>2</sub> release and absorption in pre-synthesized MEA samples

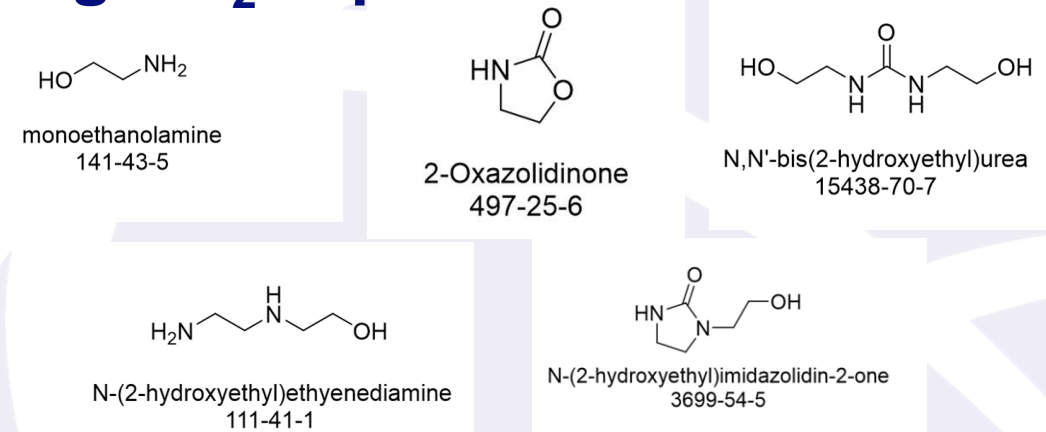

HPLC SPECTRA

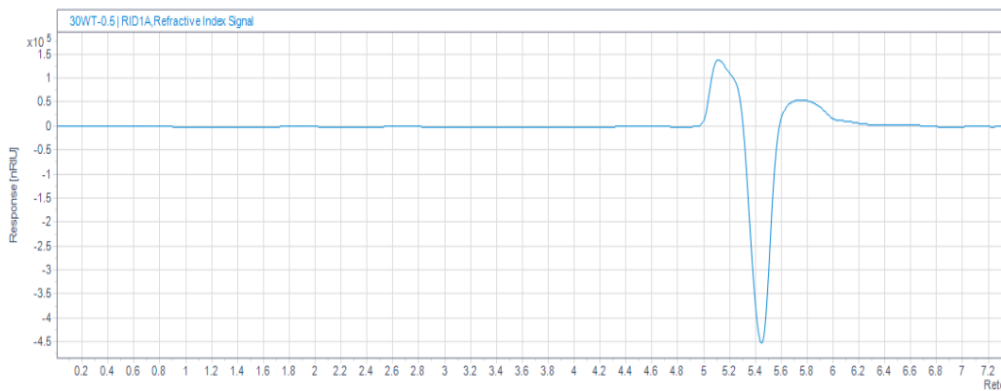

NMR SPECTRA

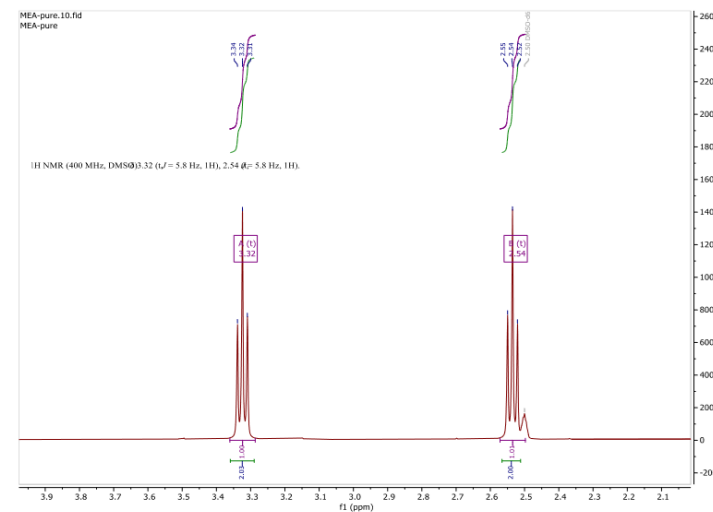

De'Ja Toole  
B.S. Chemistry



### Accomplishments

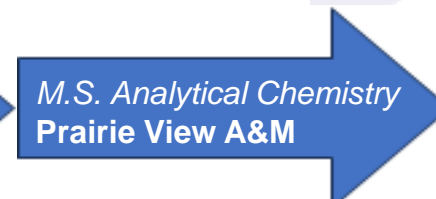
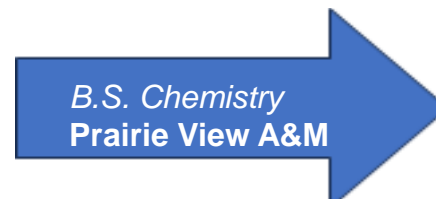

# Collaboration and Coordination: LANL-MSIs

## Computational Investigation of H<sub>2</sub> storage in GICs



Matthew Salinas

Matthew Salinas: UT-Rio Grande Valley

- Graduating Spring '24
- 2<sup>nd</sup> Summer at LANL
  - Ionic Conductivities of Zirfon and PBI
  - **Computational investigation of H<sub>2</sub> storage in GICs**
- Beginning Chemistry PhD program at Dartmouth Fall '24



Daniel Leonard  
LANL Staff Scientist

**Ionic Conductivities of Zirfon and Poly(benzimidazole) Polymers in Potassium Hydroxide Electrolyte\***

Matthew Salinas, Dr. Daniel Leonard, Dr. Sandip Maurya | Materials Physics and Applications, Los Alamos National Laboratory, Los Alamos, NM, USA

MSIPP  
CA<sup>2</sup>REERS CONSORTIUM

**Motivation:**  
The Future of Carbon-Zero Energy

An impediment to the increased use of alkaline water electrolysis (AWE) an alternative energy production process is the unsatisfactory conductivity exhibited by the ion-solvating polymer (ISP) separators through which selective reactant transfer occurs.

Discovery of an implementable ISP with excellent electronic conductivity will:

- Allow for greater current flow at lesser voltage drops
- Reduce AWE electrolyzer degradation rates by encouraging the use of lesser voltage drops
- Improve AWE electrolyzer performance

These improvements will render electrolysis a more favorable energy production process and allow clean, carbon-zero electrolysis and, by extension, hydrogen production, to exercise greater influence in the energy industry.

**Solution:**

We propose the use of two potential ISP candidates:

Zirfon:

\*C1=CC=C(C=C1)C2=CC=CC=C2C3=CC=CC=C3C4=CC=CC=C4C5=CC=CC=C5C6=CC=CC=C6C7=CC=CC=C7C8=CC=CC=C8C9=CC=CC=C9C10=CC=CC=C10C11=CC=CC=C11C12=CC=CC=C12 + \*C1=CC=C(C=C1)C2=CC=CC=C2C3=CC=CC=C3C4=CC=CC=C4C5=CC=CC=C5C6=CC=CC=C6C7=CC=CC=C7C8=CC=CC=C8C9=CC=CC=C9C10=CC=CC=C10C11=CC=CC=C11C12=CC=CC=C12

**Electrolysis of Interest:**  
The Underlying Electrochemistry

Anodic:  $2OH^- \rightarrow O_2 + H_2O + 2e^-$   
Cathodic:  $2H_2O + 2e^- \rightarrow H_2 + 2OH^-$   
Total:  $H_2O \rightarrow H_2 + O_2$

Fig. 1. AWE electrolyzer schematic illustrating the gas-producing nature of the half-reactions.

- An alkaline environment must be maintained for the diffusion of hydroxyl ions; this necessitates the use of the potassium hydroxide electrolyte.
- The gas produced by the gas evolution occurring at the electrodes, if left to diffuse, causes cell degradation and diminishes cell performance. The role of the ISP separator is to selectively diffuse only reactant and electrolyte across its length.

**Experimental:**  
Cell Components

The following cells were tested:

- Nickel Cathode, Nickel Oxide Anode
- 30 wt% KOH Electrolyte
- Zirfon or PBI ISP separator

After temperature equilibration of each cell at 30°C, 50°C, and 80°C, EIS was delivered at a constant 10 mV under a logarithmic frequency sweep from 1 MHz to 100 Hz. From the resultant high-frequency resistance (HF<sub>R</sub>) values and known electrolyte-ISP interfacial dimensions, conductivities were calculated.

**Data:**

Temperature (°C)	Zirfon HF <sub>R</sub> (Ω)	PBI HF <sub>R</sub> (Ω)
30	~100	~100
50	~200	~200
80	~400	~400

Chart 1. Conductivity of Zirfon and PBI separators at various temperatures.

Chart 2. Temperature dependence of conductivities tabulated in Chart 1.

**Analysis & Conclusion**

The data points yielded by the 500 μm-Zirfon polymer contradicted physical intuition, offering a poor basis for direct comparison with those of the PBI polymer. The data yielded by the Zirfon<sup>+</sup> polymer should more truly reflect the conductivity of Zirfon and will instead be considered.

Chart 2 illustrates that the ionic conductivity of Zirfon<sup>+</sup> exhibits greater sensitivity to temperature than does PBI, exhibiting twice the ionic conductivity at 30°C and nearly four times the ionic conductivity at 80°C. On the basis of ionic conductivity at the temperature range considered, Zirfon<sup>+</sup> greatly excels in comparison to PBI, undermining the attractiveness of the latter for use in alkaline water electrolyzers.

\*Note: This poster is a draft. Additions and revisions will be made.

**Acknowledgments:**  
LANL, MSIPP, and CA<sup>2</sup>REERS have made this research possible.

**References:**

1. Salinas, M., Leonard, D., Maurya, S. (2023) On the Discovery of Alkaline Water Electrolysis Membrane's Thesis. Retrieved from [https://www.lanl.gov/document/20230313/MSIPP\\_20230313/MSIPP\\_20230313.pdf](https://www.lanl.gov/document/20230313/MSIPP_20230313/MSIPP_20230313.pdf)

2. G. Liu, et al., "Electrochemical Impedance Spectroscopy for the Investigation of Alkaline Water Electrolysis Membranes," *ACS Energy Letters*, 8(2019), doi: 10.1021/acsenergylett.8b02009

3. Liu, H., et al., "Investigation of Poly(arylene ether sulfone) Membranes for Alkaline Water Electrolysis Membranes," *Membranes*, 10(2020), doi: 10.3390/mem1002009

# Collaboration and Coordination: LANL-MSIs

## Developing Mechanically Enhanced Reinforced Membranes

- University of Texas-Rio Grande Valley: Marina Pacheco
- Summer student at LANL '22 and '23
- Fabrication of reinforced membranes using a porous polypropylene substrate and *in-situ* polymerization to demonstrate enhanced mechanical properties
- Marina fabricated an anion exchange membrane and demonstrated hydroxide conductivity of  $31 \text{ mS cm}^{-1}$  at  $80^\circ\text{C}$  and tensile strength of  $36 \text{ MPa}$  with elongation at break of  $56\%$ .
- Marina is pursuing her Master's degree in Chemistry at UTRGV and will continue to work on hydrocarbon membrane development



Sarah EJ Park, LANL staff



### Development of Reinforced Ion Exchange Membranes

Marina S. Pacheco,<sup>1,2</sup> Sandip Maurya,<sup>2</sup> Sarah Eun Joo Park<sup>1</sup> | <sup>1</sup>University of Texas Rio Grande Valley, <sup>2</sup>MPA-11: Materials Synthesis and Integrated Devices, Los Alamos National Laboratory

#### Research Goals

- Fabricate reinforced anion exchange membranes (AEMs) by polymerizing and in-situ-crosslinking of 4-vinylbenzyl chloride (VBC) with a porous polypropylene substrate to prepare mechanically strong AEMs.
- Obtain anion exchanging trimethyl ammonium groups via membrane treatment with trimethylamine for quaternization.
- Characterize membranes for evaluation of reinforced AEM properties compared to free-standing membranes.
- Apply the reinforcement strategy to fabricate proton exchange membranes (PEMs).

#### Background

Ion-exchange membranes are critical to membrane-based water electrolysis in transporting oppositely charged ions and consist of polymers with ionic group attached to their backbone.

#### AEM-BASED WATER ELECTROLYSIS

Desired properties for AEMs:

1. High Anion Conductivity: Ammonium functionalized polymers for anion exchange via quaternization
2. Mechanical Stability: mechanically strong and chemically inert polymer substrates for membrane reinforcement (e.g. porous polypropylene)
  - crosslinking for additional strength to both the polymer backbone and the porous substrate

#### SYNTHESIS OF REINFORCED AEM

#### Membrane Characterization

Figure 1. ATN-IR Spectra of Porous PP substrate, VBC, PP polymerized film, Quaternized V8\_PP with TMAH2O, and Quaternized V8\_PP with TMA/EtOH

AEM	Thickness (μm)	Water Uptake (wt%)	Swollen Thickness (μm)	Water Content (%)	Exchange Capacity (meq/g)	In-Plane Conductivity (mS/cm)
GAU_PP 10	76±2	95.5	3.08	2.88	7.41 <sup>a</sup>	1.16±0.01 <sup>b</sup>
GAU_PP 20	41±2	95.5	3.07	3.44	8.19 <sup>a</sup>	0.75±0.02 <sup>b</sup>
GAU_PP 30	39±1	95.5	2.90	2.41	37.71 <sup>a</sup>	4.85±0.02 <sup>b</sup>
GAU_PP 40	-	-	-	-	-	31.01 <sup>c</sup>

<sup>a</sup> Average IEC value for two sample sizes determined via Moisture (VCl) anion conductivity. <sup>b</sup> Conductivity performed at 80°C and 100%RH. <sup>c</sup> Conductivity performed at 80°C and 100%RH.

#### DYNAMIC MECHANICAL ANALYSIS

Figure 3. DYNAMIC MECHANICAL ANALYSIS at 50% humidity and heating rate of 20°C/min for reinforced AEM.

#### ONGOING WORK

Figure 4. 1H-NMR Spectra of (a) 4-vinylbenzyl chloride and (b) quaternized (4-vinylbenzyl) triacetate

#### SUMMARY

- A variety of reinforced AEMs were synthesized with varying IEC.
- A polymer with the same composition was synthesized without the substrate, however it couldn't be formed as a free-standing film.
- High IEC polymers produced brittle membranes, while the ideal IEC of 2.0 meq/g possessed more flexible reinforced membrane.
- A membrane demonstrated tensile strength ( $36 \text{ MPa}$ ) with elongation at break of  $56\%$ . Hydroxide conductivity at  $80^\circ\text{C}$  was determined to be  $31.01 \text{ mS/cm}$ .

#### ACKNOWLEDGEMENTS

This work was supported by the CAREERS program and the University of Texas Rio Grande Valley. My appreciation goes out to my college advisor, Javier Macosay-Torres and my co-mentor, Tammy Kozdrow for their help in acquiring this great opportunity. I am also grateful to Gulmin Ahn and Ajay Kumar for their support with laboratory techniques.

#### REFERENCES

1. Journal of Membrane Science, 2021, 643, 119110, pp. 28-35.
2. ACS Energy Letters, Vol. 7, 2022, pp. 3447-3457.
3. ACS Infectious Diseases, Engineering Chemistry Research, Vol. 83, 2013, pp. 10284-10279.

May 2023

May 2024

UGS  
at LANL

GRA

Accomplishments



Accomplishment

# Industry Collaboration-General Motors

## Characterizing Bipolar Plate (BPP) corrosion with novel coatings for fuel cells

- Designed an innovative and modular sample holder for direct comparison of corrosion data
- Enhanced setup for ideal uninterrupted testing

**Corrosion Cell**

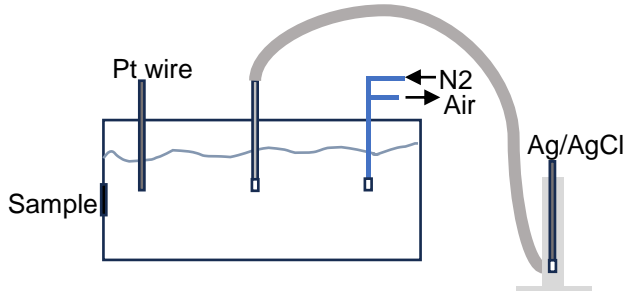

- Engineered a custom ICR template design for high resolution data

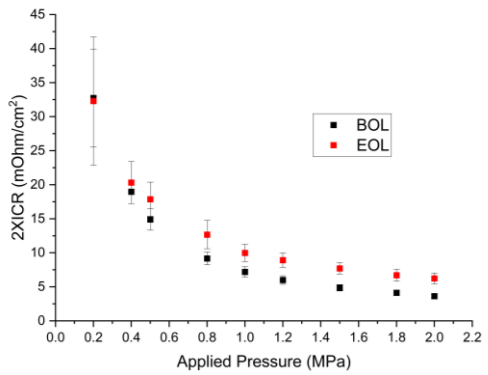

### Interfacial Contact Resistance

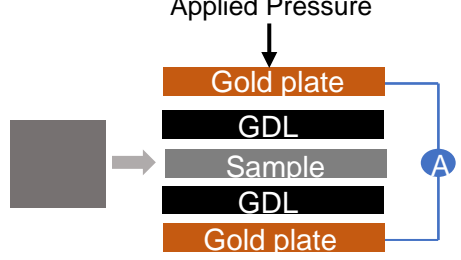

- Unique design allows for data accuracy and reproducibility

- Inductively-Coupled Plasma Mass Spectroscopy (ICP-MS) for low-level detection of cation release from materials

Element Concentration (ppb)					
(47) Ti	(52) Cr	(55) Mn	(56) Fe	(57) Fe	(60) Ni
<0.000	0.4444	0.2441	<0.000	<0.000	0.2370
<0.000	0.0826	0.1721	<0.000	<0.000	0.0677
<0.000	0.5109	0.3653	<0.000	<0.000	0.2302
<0.000	0.2333	0.2370	<0.000	<0.000	0.0203



**Lexy Murphy**  
B.S. Computer Engineering



**Lyra Troy**  
M.S. Chemical Engineering



**De'Ja Toole**  
B.S. Chemistry

### Highlights

- ✓ Characterized the corrosion resistance of new coatings on BPP materials for GM
- ✓ Designed high-precision, reproducible, novel method for measuring contact resistance
- ✓ Provide ICP-MS capability for GM to determine cation release rates

### Accomplishments



# Industry Collaboration-Treadstone Collaboration

## Characterizing the corrosion of coated and textured bipolar plated for fuel cells



- AST Development
- Perform potentiodynamic and potentiostatic corrosion tests on novel bipolar plate materials supplied by Treadstone
- Characterize the corrosion voltage and currents during accelerated stress tests to analyze the performance of the bipolar plates in a fuel cell operating environment



### Corrosion cell

### Highlights

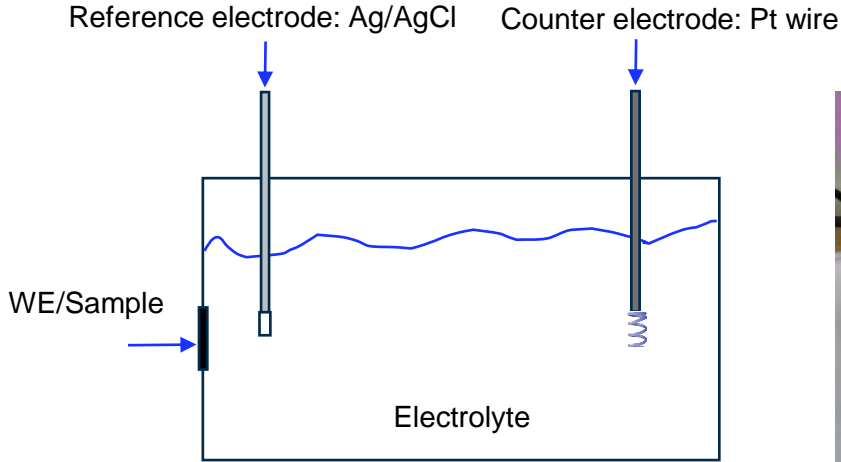

- ✓ Characterized the corrosion of novel bipolar plates with different coatings materials for Treadstone
- ✓ Analyzed how varying surfaces of bipolar plates affect their performance during operation
- ✓ **Developed new methods for structural health monitoring of fuel cells**

# National Lab Collaboration

## Manufacturing Novel Electrodes for Improved Performance



Rangachery Mukundan



Jabari Allen  
Graduate Research Assistant



- Collaborative work between Berkley Lab, UT EI Paso, and LANL
- Co-Advisors: Tommy Rockward, Rangachary Mukundan
- Monthly Meetings



Manufacturing novel electrodes

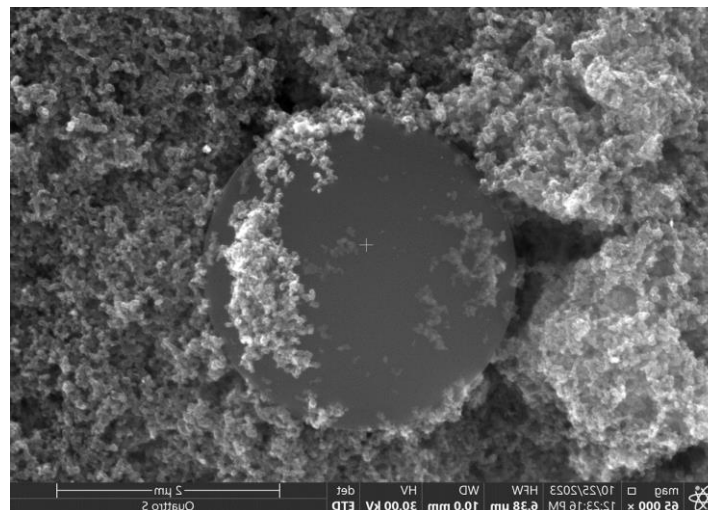

Investigating distribution of material on electrode surface using SEM

Examination of substrate and catalyst ink interaction

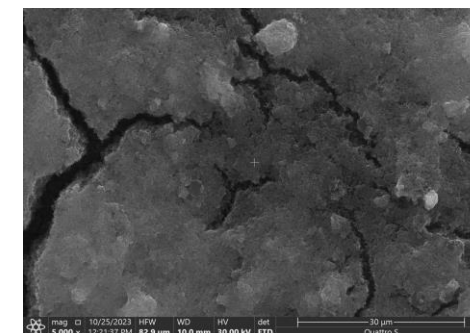

Heat map of platinum loading on spray coated membrane using X-ray fluorescence mapping

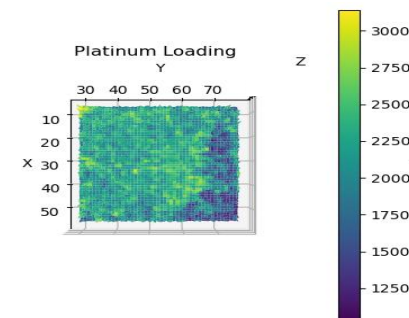

Started B.S. Computer Engineering Spring 2020 at FAMU

2021 Summer internship at LANL

Graduated B.S. in Spring 2023



Joined ASTERIX in Fall 2020 as an undergraduate research assistant

2022 internship in MPA-11 at LANL

GRA position at LANL while pursuing Masters at UTEP



Accomplishments

# M2FCT Collaboration-General Motors

## Determining parameters needed for membrane durability and lifetime predictions for fuel cells

- Characterize  $Ce^{3+}$  movement in novel membranes using controlled test cell and XRF imaging techniques
- Utilize cation migration profiles to determine critical lifetime parameters from modeling



**Lyra Troy**  
M.S. Chemical Engineering

### Membrane samples in test cell

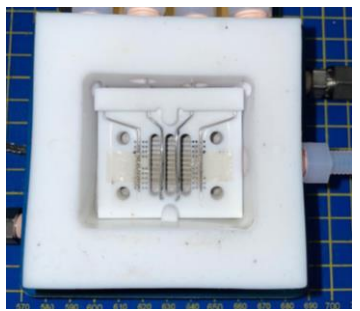
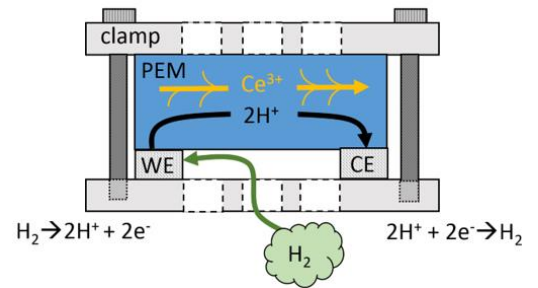

### XRF Mapping

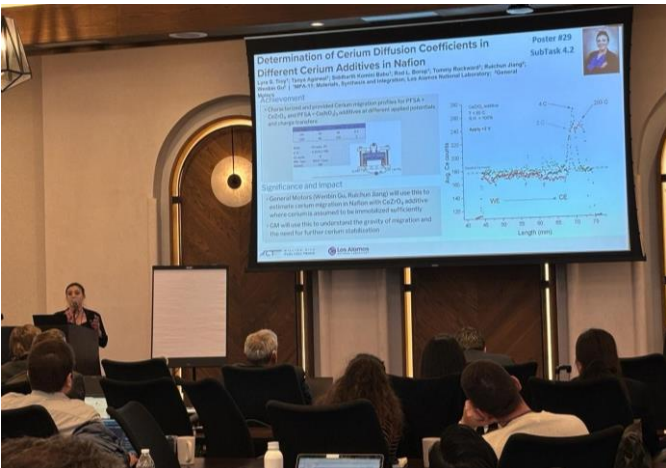
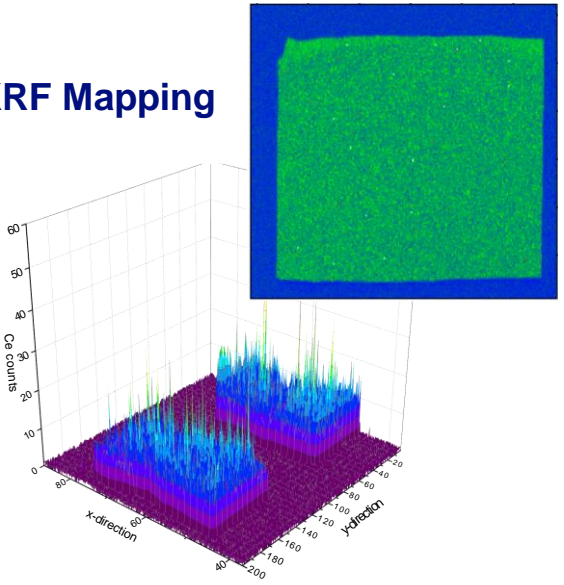

### Highlights

- ✓ Presented findings at M2FCT Consortium
- ✓ Characterized cerium mobility in membranes with new additives
- ✓ Provided General Motors with experimental data needed for modeling and membrane lifetime parameters

### Accomplishments



**May 2020**  
B.S. Chemical Engineering  
B.S. Mathematics  
University of Arizona

**Dec. 2022**  
M.S. Chemical Engineering  
University of Arizona

**Oct. 2022-Present**  
Post Master's Researcher  
Los Alamos National Laboratory



# H2NEW Collaboration

## Building New Capabilities and Enhancing Skillsets



Daniel Leonard & Tommy Rockward  
LANL Staff Scientists

Brandon Cepeda – UT-EI Paso

- Graduate Research Assistantship
  - **Started Spring '24 at LANL**
  - Design of lab-scale, high-pressure liquid alkaline water electrolysis test station
- Work will build new capabilities for Hydrogen for Next-generation Electrolyzers of Water (H2NEW) Consortium
- Electrode design and development for battery replacement



# Internal Cross-Group Collaboration: LANL

**Gonzalo Seisedos**  
**Ph.D. in Materials Science and Engineering**  
**Postdoc Research associate at LANL in the MPA-11 group**



2019

- B.S. Mechanical Engineering from Florida international University (FIU)
- Started Ph.D. in Materials Science and Engineering at FIU

2021

- Joined Partnership in Research and Education Consortium in Ceramics and Polymers (PRECCAP)
- Interned at Los Alamos National Laboratory (LANL) as an MSIPP Graduate Research Assistant

2023

- Obtained Ph.D. in Materials Science and Engineering from FIU
- Started as a Postdoc research Associate at LANL at the MPA-11 group

2024

- **Develop novel techniques for the structural health monitoring of corroding systems and MEA manufacturing**

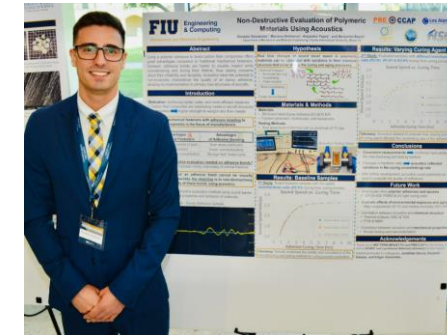

# Collaboration and Coordination: LANL- Navajo Technical University

## Collaboration with Navajo Technical University supports clean hydrogen careers

Internships, high-tech equipment offer learning opportunities



A poster presentation on electrochemistry was part of the focus of the Navajo Technical University partnership at the Four Corners Energy & Water Innovation Student Symposium in April 2023.

A newly expanded partnership between the Laboratory and Navajo Technical University (NTU) is helping foster a STEM-adept workforce ready to contribute to a high-tech, clean energy future with a concentration on fuel cell technology and additive manufacturing.

The Department of Energy recently helped expand Los Alamos' partnerships with NTU by establishing the Hydrogen and Fuel Cells Technology Office (HFTO) Native American Fellowship, a pilot program that offers Lab internships for NTU students, connects students with real-world research experiences and funds the purchase of advanced scientific equipment installed at the tribal university. The new program is also supported by and builds upon similar efforts from the National Nuclear Security Administration's Minority Serving Institutions Partnership Program.

# Modification of a Slot Die Coater Electrode Manufacturing: Project 1

Ink Parameterization and Surface Treatment

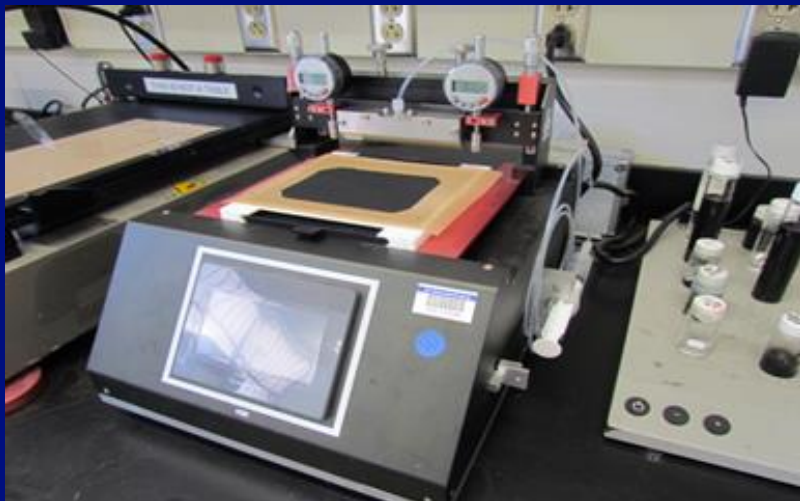

Slot Die Coater

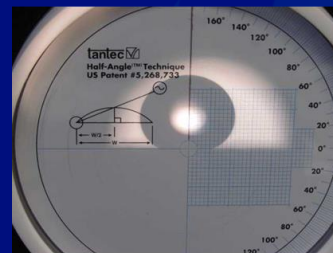

Pristine;  $\theta = 139.5^\circ$

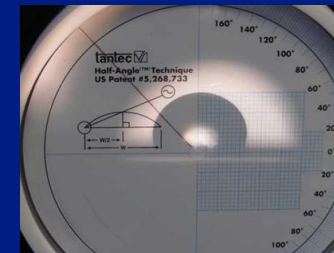

30% IPA;  $\theta = 106.3^\circ$

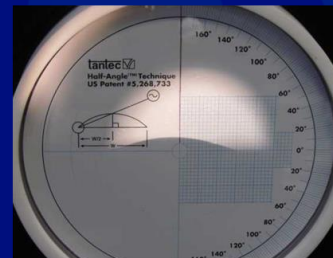

50% IPA;  $\theta = 27.5^\circ$

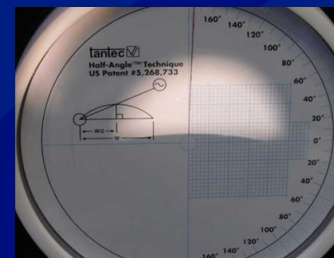

70% IPA;  $\theta = 14.9^\circ$

Wettability challenges on  
GDLs



**Turtle Mountain**  
Community College

# Accomplishments: Team 1

## Navajo Technical University - Los Alamos Collaboration

### Flat Slot Die Coater with modification to allow for pre-treatment to be applied

#### Problem:

Pre-treatment dries too fast causing the substrate to crack before final solution can be administered.

#### Requirements:

- ❖ Mirror the slot die to create a second die for pre-treatment.
- ❖ Spacer would need to be modified.
- ❖ One blade, two dies.
- ❖ Design a secondary slot die that allows for pre-treatment to be applied within adequate amount of time.

Original slot die only had one orifice to allow for one solution to run at a given time.

The technician would have to connect the pre-treatment, run the program, then disconnect the pre-treatment and change over to the final solution and run the program again.

The time spent on the change over would occasionally cause the substrate to dry out and crack resulting in the technician having to start over.



#### First Solution:

The prototype shown below is only one side because we wanted to run a test before printing the rest of the prototype. The Prototype did fail because water was Not able to pass through the channel. The extruded hole is being reposition at an Angle.



#### Second solution:

Create a slot die with same dimensions as the original. The die would attach to the original and cut down on the change over time. Separate channel for pre-treatment to.

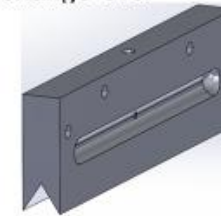

**Joel Yazzie**  
B.S Mechanical  
Engineering

**Wynona Wilson**  
B.S Mechanical  
Engineering

#### Achievements:

Having two solutions allows for more than one option.

Being able to show our creativity and still have a final part.

# AM Enables Solutions to Complex MEA Manufacturing Challenges: Team 2

## Slot Die Head Structure

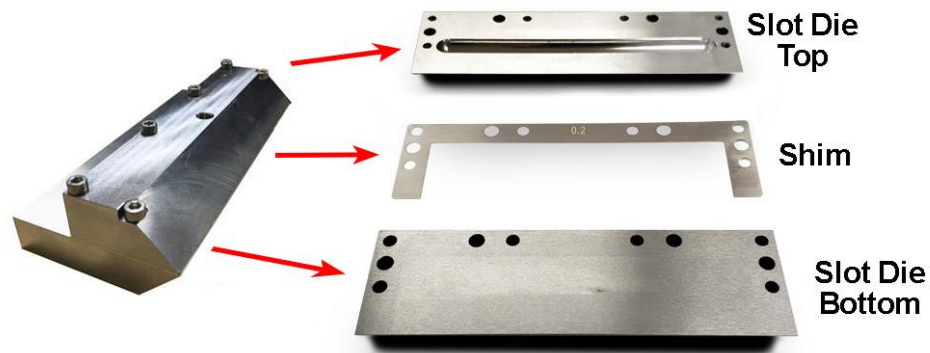

## Design considerations to improve electrode manufacturing process

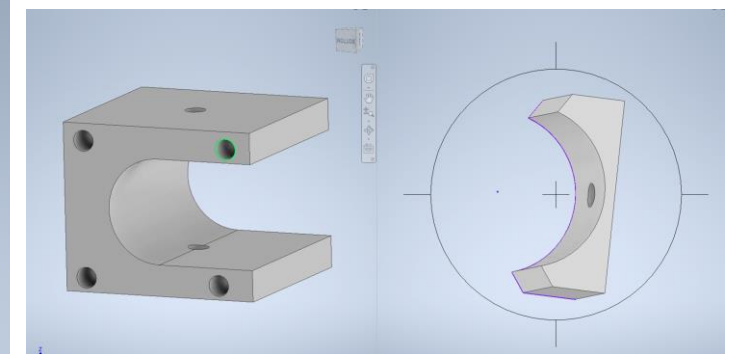
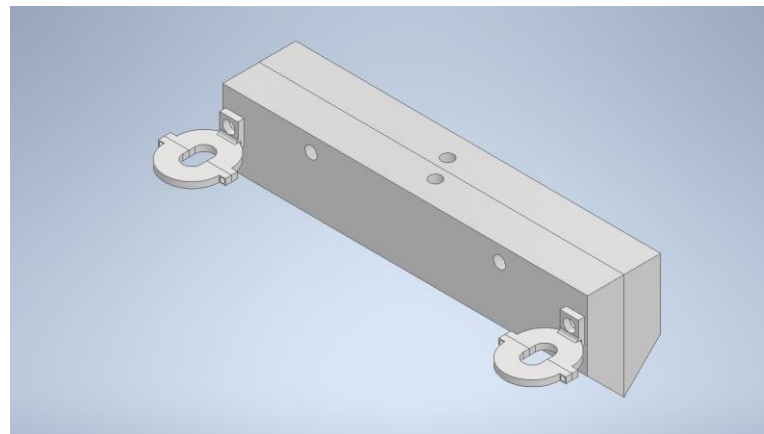
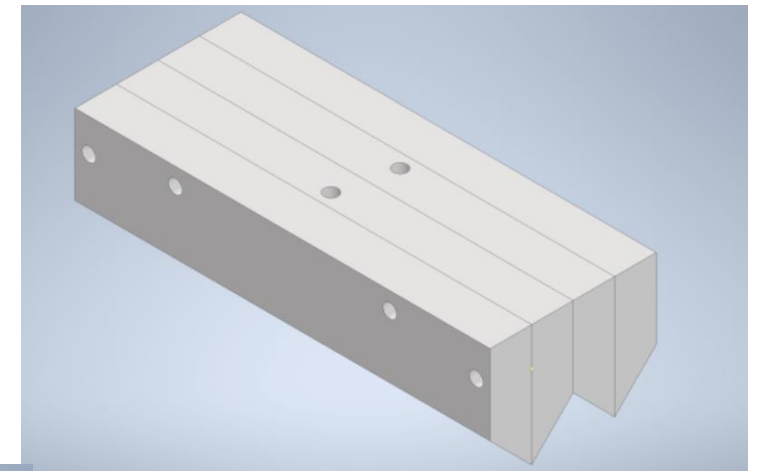
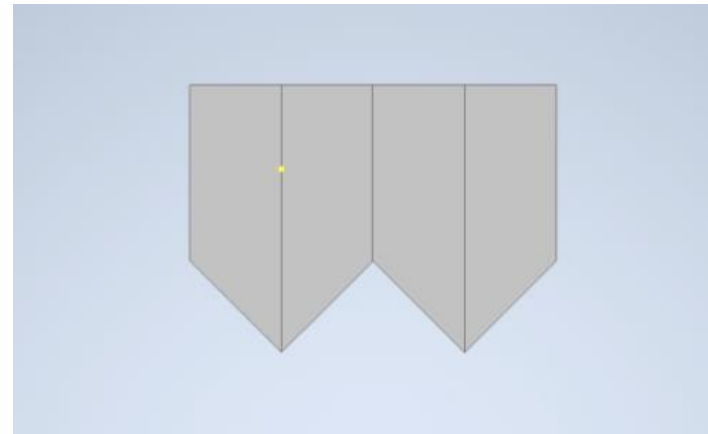
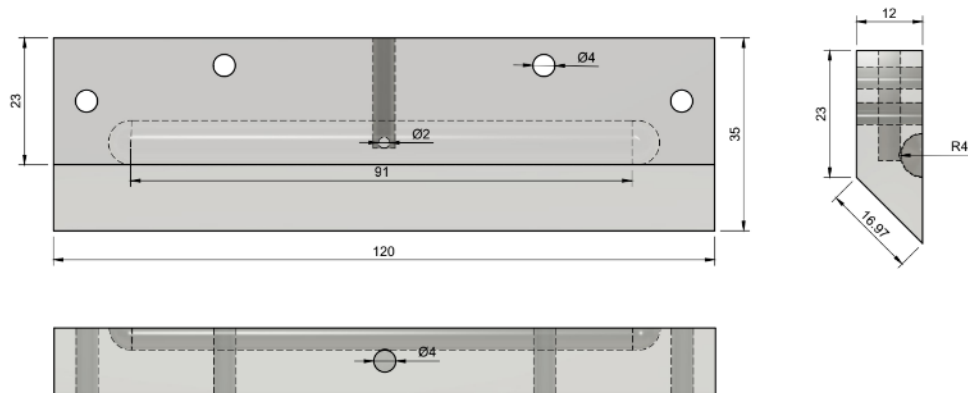

# Summary & Proposed Future Work

## Recruit, Train and Retain:

- Continued to provide opportunities and collaborations in the form of internship, trainings, thesis advisory, and joint project interactions, etc.
- Maintained the momentum developed over the prior years
- Scholars are utilizing their skillsets to make valuable contributions and are learning new skills

**”Any proposed future work is subject to change based on funding levels”**

- Build upon successes to show ROI to sponsors
- Sustain the program to afford more opportunities
- Recruit, train and retain
- Grow the number of collaborators
- Grow the number of MSIs

# Acknowledgements

## **DOE EERE Hydrogen and Fuel Cell Technologies Office**

- Director: Sunita Satyapal
- Program Manager: Dimitrios Papageorgopoulos

## **NNSA Minority Serving Institutes Partnership Program**

- Jenny Kline, Director
- David Canty, Program Manager
- Betsy Snell, Program Manager.

## **The Director's Office Under-Represented Minority Partnership Program**

- Director Thom Mason

## **Mentors**