

## VII.H.5 Development of Sensors for Automotive Fuel Cell Systems

*Thomas Clark<sup>1</sup> (Primary Contact) and Brian Knight<sup>2</sup> (United Technologies Research Center)*

*UTC Fuel Cells*

*195 Governor's Highway*

*South Windsor, CT 06074-2419*

*<sup>1</sup>Phone: (860) 727-2287; Fax: (860) 998-9811; E-mail: tom.clark@utpwr.com*

*<sup>2</sup>Phone: (860) 610-7293; Fax: (860) 660-1204; E-mail: Knightba@utrc.utc.com*

*DOE Technology Development Manager: Donna Ho*

*Phone: (202) 586-8000; Fax: (202) 586-9811; E-mail: Donna.Ho@ee.doe.gov*

*DOE Project Officer: Reg Tyler*

*Phone: (303) 275-4929; Fax: (303) 275-4753; E-mail: Reginald.Tyler@go.doe.gov*

*Contract Number: DE-FC36-02AL67616*

*Subcontractors:*

*ATMI, Inc., Danbury, CT*

*Illinois Institute of Technology (IIT), Chicago, IL*

*NexTech Materials, LTD, Worthington, OH*

*United Technologies Research Center, East Hartford, CT*

*Start Date: April 1, 2002*

*Projected End Date: December 31, 2005*

### **Objectives**

- The objective of this effort is to develop technology and a commercial supplier base capable of supplying physical and chemical sensors required to optimize the operation of proton exchange membrane (PEM) fuel cell power plants in automotive applications.

### **Technical Barriers**

This project addresses the following technical barriers from the Fuel Cells section of the Hydrogen, Fuel Cells and Infrastructure Technologies Program Multi-Year Research, Development and Demonstration Plan:

- A. Durability
- H. Sensors

### **Approach**

The team assembled for this project will perform the following tasks:

- Obtain representative samples of physical parameter sensors currently available to meet the requirements specified by DOE.
- Design and construct a facility for testing physical and chemical sensors under simulated reformer-out conditions.
- Determine the suitability of state-of-the-art physical parameter sensors for the extreme environment of a PEM fuel cell power plant by testing them in a combination of laboratory and simulated fuel cell flow stream environments.
- Assist the sensor manufacturers, where necessary, to modify their sensors to achieve the requisite performance and durability goals.

- Modify baseline chemical sensing technologies to create sensors capable of operating in a PEM fuel cell environment.
- Validate and document the performance and durability of the developed sensors by exposing them to a combination of laboratory and simulated fuel cell flow stream environments.
- Install the developed sensors on a PEM fuel cell at UTC Fuel Cells (UTCFC) for final testing.

### **Accomplishments**

- Designed and constructed physical and chemical sensor test facility for simulated reformer test gas stream.
- Developed lower explosion limit (LEL) sensor for H<sub>2</sub> that meets cost and technical goals.
- Sensor is ready for commercialization.
- Developed stack H<sub>2</sub> sensor with dynamic response of less than 2 seconds in humid gas streams containing up to 70% H<sub>2</sub>.
- Demonstrated 5 ppm CO sensing in humid gas stream in the presence of 40% H<sub>2</sub>.
- Demonstrated H<sub>2</sub>S sensing at 10 ppb level with new sensing technology.
- Demonstrated ammonia sensing technology at 5 ppm level at 75°C.
- Completed physical sensor survey and candidate sensor evaluation.

### **Future Directions**

- Optimize sensor performance and reliability.
- Determine cross-sensitivity of sensors to other syngas components.
- Evaluate other chemical sensing technologies.
- Evaluate physical and chemical sensors in United Technologies Research Center (UTRC) facility followed by tests at UTCFC on the PC35 gasoline-fired reformer breadboard facility.

---

### **Introduction**

The present state-of-the-art in fuel cell power plant sensor technology is embodied in the UTCFC PAFC PC 25 and PEM S200 power plants. Sensors measuring all of the parameters defined by DOE are utilized in designing and setting up these power plants. However, none of the chemical sensors and only a very few of the physical sensors are “onboard” the power plant, and only temperature and stack differential pressure, in the S200, are measured continuously for control purposes. Production automotive fuel cell power plants require all of these sensors to be onboard the power plant and to provide data signals on a continuous basis to optimize fuel cell operation and to protect the cell stack from damage.

### **Approach**

UTCFC is evaluating the sensors described above in the appropriate test facilities, supplying a synthesized gas stream of known inlet gas

composition, and determining the response accuracy of each sensor at the required operating temperature. By controlling the inlet gas composition and mass flow, a fixed reference will be established to which the sensor response will be compared as a function of time. This effort is being conducted in UTRC, IIT and UTCFC facilities. Baseline sensor technologies taken from a combination of production PC25, S200 and fuel cell development laboratory applications are being subjected to a series of performance, durability and cost reduction studies. Concurrent with this portion of the task, a detailed review of alternate sensors is being conducted by IIT. New advanced solid state electrochemical and micro electro-mechanical system (MEMS) sensors are being developed at NexTech and ATMI. This work includes new transduction principle development, new sensing materials and fabrication development, and sensor prototyping. Sensors will be ranked according to their probability of successful test results. Initial qualification tests are being conducted

by IIT in the PEM Fuel Cell Benchmark Facility. These tests consist of installation and exposure of baseline sensor technologies to precisely controlled temperature, humidity, pressure, and gas mixture conditions. Sensor response versus these parameters is logged.

Second-level testing is being conducted at UTRC. During these tests, the sensors are installed in a chamber through which gases simulating an autothermal reactor (ATR) exhaust stream flow (created by mixing gases, heating and humidifying as necessary to obtain the desired composition). The sensors are evaluated for accuracy, speed of response, and cross-sensitivity to non-target parameters and test gas parameters. The tests operate continuously as a PC utilizing National Instruments LabView software controls and log all test parameters, including gas composition, sensor output, and control safety systems. It is assumed that repetition of the above testing cycle will be required due to non-performance of some sensors. If baseline sensors cannot demonstrate the required performance, alternates will be selected.

**Results**

A team has been assembled to address the development and evaluation of physical and chemical sensors meeting the requirements listed above. Table 1 shows the breakdown of responsibilities for each of the team members

UTRC has constructed a physical and chemical sensor test facility capable of subjecting candidate sensors to gas compositions simulating operation in

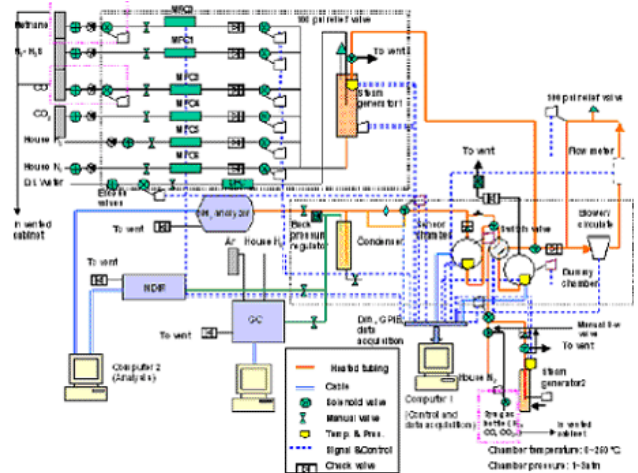

**Figure 1.** UTRC PEM Fuel Cell Gas Stream Simulator and Sensor Testing Rig

a gasoline/natural gas-fueled reformer based fuel cell system. IIT is evaluating all sensors developed during execution of this project in their PEM fuel cell test facility. The UTRC facility design is shown in Figure 1. NexTech Materials, Inc. has multiple test platforms for development of electrochemical and solid-state sensors. ATMI has developed H<sub>2</sub> safety and pre-stack sensors using a micro-hotplate design.

Table 2 summarizes the results of the physical sensor survey and testing conducted at UTRC. The results shown indicate the candidate physical sensor technologies that have been selected that will meet the technical goals of the project. UTRC continues to search for new sensing technologies as the project progresses and will be interacting with Honeywell Corporation in their sensor development efforts under their DOE-funded project.

**Table 1.** Sensor Development Team Responsibilities

Team Member	T	'P	RH	flow	O <sub>2</sub>	CO	H <sub>2</sub>	SO <sub>2</sub>	H <sub>2</sub> S	Technological Expertise / Responsibility
UTCFC	X	X	X	X	X	X	X	X	X	Testing on \$300 Breadboard
UTRC	X	X	X	X	X	X	X	X	X	Testing in Reformate Simulator
ATMI							X	X	X	Develop Using MEMS Silicon Microhotplate
IIT	X		X		X	X	X	X	X	Testing in Benchmark Facility
NexTech						X		X	X	Develop Using Solid State Electrochemical

**Table 2.** Results of Physical Sensor Survey

Sensor	Operating Principle	Positive Attributes	Development Needs
Temperature	Thermistor	0 to 250°C, -40 to 750°C	Response time needs improvement
Pressure	Strain Gauge (Druck)	Silicon-based integrated circuit compatible fabrication	Mass production and miniaturization
Relative Humidity (RH)	Polymer capacitive (Panametrics)	0 to 180°C, 0-100% RH	Improve recovery from condensing flow regime
Flow	Thermal dissipation		Response fluctuation due to condensation

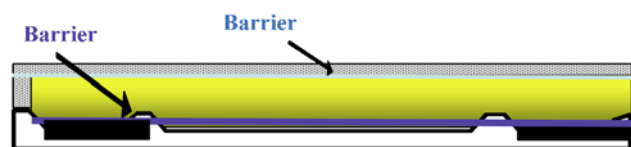
**Figure 2.** ATMI Micro-Hotplate Sensor Platform for H<sub>2</sub> Sensing

## H<sub>2</sub> Sensors Development

The H<sub>2</sub> safety sensor was designed to operate in ambient conditions and detect H<sub>2</sub> levels up to 4% in air. ATMI utilized their micro-hotplate design, shown in Figure 2, as a basis for the sensor platform. Tests have validated sensor operation in temperatures from -30 to 80°C, with a response time of <1 s. Humidity ranged from 10-98%. Selectivity from hydrocarbons was demonstrated with an uncertainty of 5%. A five-year lifetime is predicted. Results are shown in Figure 3. The pre-stack sensor has been tested with H<sub>2</sub> concentrations ranging from 1-100% at temperatures ranging from 70-150°C. Response times (T<sub>90</sub>) demonstrated ranged from 0.1-1 seconds at 1-3 atm total pressure, 10-30 mole % water, with CO<sub>2</sub> and N<sub>2</sub> ranging from 30-75%, and an uncertainty ranging from 1-10% full scale. Prototype sensor performance in wet gas streams at various H<sub>2</sub> concentrations is shown in Figure 4.

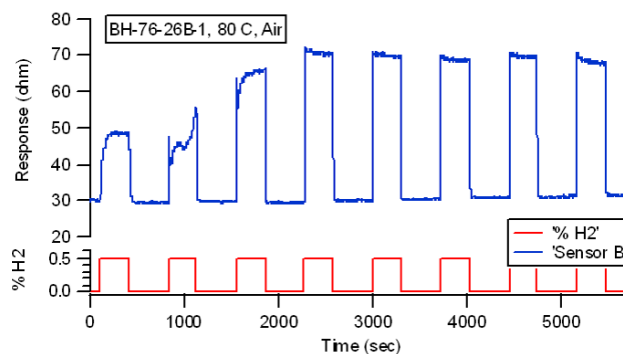
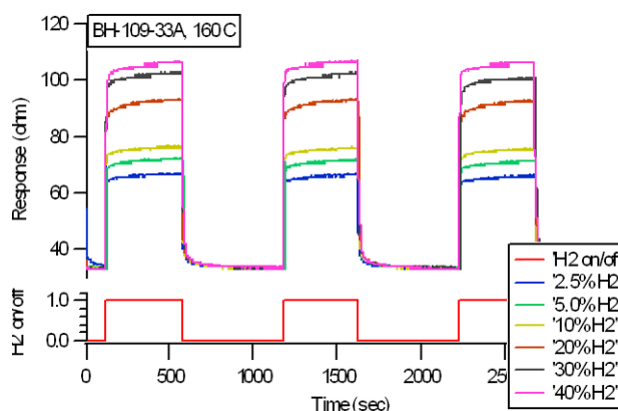
**Figure 3.** ATMI Safety Sensor Response in Ambient Air Conditions**Figure 4.** ATMI Pre-Stack H<sub>2</sub> Sensor Response in Wet Environments for Various H<sub>2</sub> Concentrations

## CO Sensor Development

NexTech Materials has developed solid oxide fuel cell (SOFC)-based sensor technology with electrodes engineered to respond to CO that shows reversible and quantitative response to CO in wet N<sub>2</sub>/H<sub>2</sub> gas streams. Results are shown in Figure 5. Future work will focus on schemes to improve sensitivity to CO in the 0-100 ppm range and testing cross-sensitivity to alternate syngas components.

## H<sub>2</sub>S Sensor Development

ATMI has developed Rh-based MEMS-based sensors that show reversible and quantitative

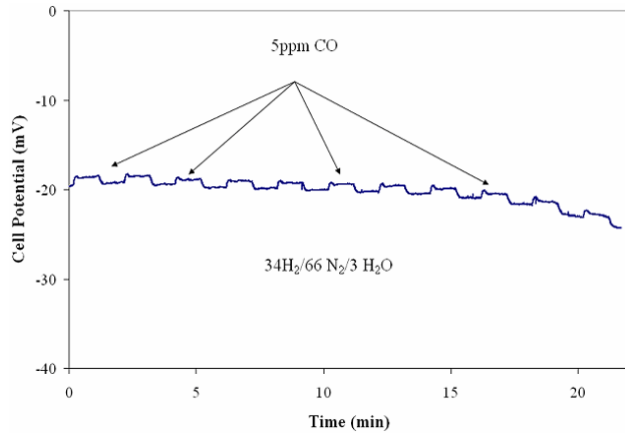

**Figure 5.** NexTech Materials CO Sensor Response in Humid Gas Streams

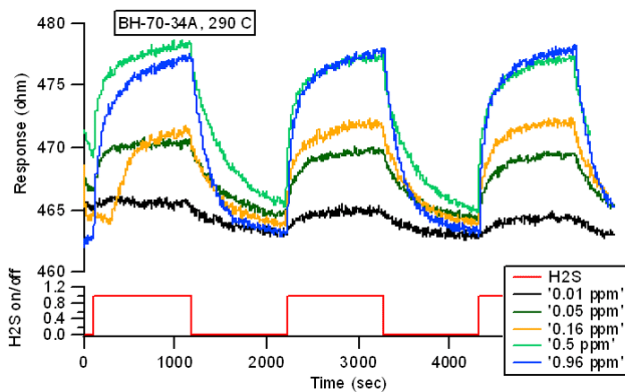

**Figure 6.** ATMI H<sub>2</sub>S Sensor Response in Humid Gas Streams

response to H<sub>2</sub>S, as demonstrated in Figures 6 and 7. NexTech is currently evaluating resistive-based sensor technologies that have demonstrated no cross-sensitivity to CO. Future work will focus on measuring lower sulfur concentrations and cross-sensitivity to individual syngas components.

As shown in Figure 7 the ATMI H<sub>2</sub>S sensor has a linear  $\Delta R$  response to the log of concentration of H<sub>2</sub>S from 10 to 1000 ppb. Figure 8 shows the response of the NexTech Materials H<sub>2</sub>S sensor at low H<sub>2</sub>S concentrations.

## Conclusions

The hydrogen safety sensor developed by ATMI has been shown to meet all program goals and is in a

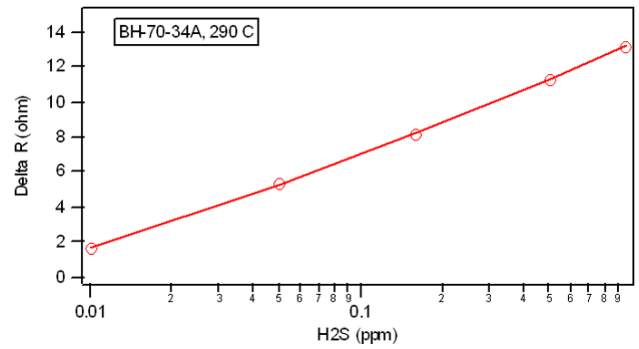

**Figure 7.** ATMI H<sub>2</sub>S Sensor Response at Low H<sub>2</sub>S Concentration

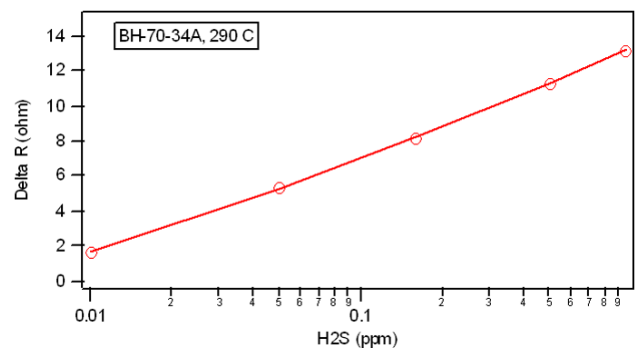

**Figure 8.** NexTech Materials H<sub>2</sub>S Sensor Response at Low H<sub>2</sub>S Concentration

state of readiness for commercialization. The pre-stack H<sub>2</sub> sensor developed by ATMI has demonstrated excellent performance and will be optimized in future efforts. The work being performed by ATMI and NexTech Materials has resulted in candidate chemical sensors that will meet the program goals, although optimization is still needed. This will take place during the FY 2005 effort. IIT will continue to evaluate sensors in their test facility and will continue their sensor survey efforts to identify alternative sensing technologies. UTRC will continue evaluation of physical and chemical sensors and coordination of the efforts of the subcontractors as well as continuing interaction with Honeywell Corporation in its physical sensor development project.

## FY 2005 Publications/Presentations

1. Development of Sensors for Automotive Fuel Cell Systems 2004 4<sup>th</sup> Quarter Report, submitted December 8, 2004.

2. DOE Sensor Program 4<sup>th</sup> Quarter Review, presented March 23, 2005.
3. DOE Hydrogen & Fuel Cells Annual Program Review, May 26, 2005.
3. "Solicitation for Financial Assistance Applications No. DE-RP04-01AL67057 Research and Development and Analysis for Energy Efficient Technologies in Transportation and Buildings Applications;" DOE Albuquerque Operations Office, November 21, 2000

### **References**

1. DOE Workshop; "Sensor Needs and Requirements for Fuel Cells and CIDI/SIDI Engines," Robert S. Glass, Ed., published by Lawrence Livermore National Laboratory, April, 2000
2. Hydrogen, Fuel Cells & Infrastructure Technologies Program Multi-Year Research, Development and Demonstration Plan, June 3, 2003