

Solar Hydrogen Production with a Metal Oxide Based Thermochemical Cycle

Nathan Siegel, Tony McDaniel, Ivan Ermanoski

Sandia National Laboratories
Solar Technologies Department

DOE Annual Merit Review
5/12/2011

Project ID: PD081

Timeline

- Project Start Date: 06/2004
- Project End Date: 10/01/2011*
- Project Complete: 80%

Budget

- Total project funding to date
 - DOE share: \$ 3,452K (2004-2011)
 - Contractor share: 20% cost share on contracts
- Funding received in FY10: \$ 60K
- Funding for FY11: \$ 250K + \$620K (c/o)

*Project continuation and direction determined annually by DOE

Barriers

- Barriers addressed
 - U: High temperature thermochemical tech.
 - V: High temperature robust materials
 - X: Coupling solar and thermochemical cycles

Partners

- Collaboration with the University of Colorado at Boulder (Al Weimer)

Conceptual Design and Operation of the Particle Reactor

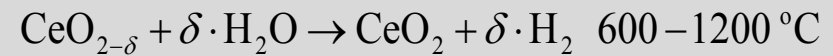
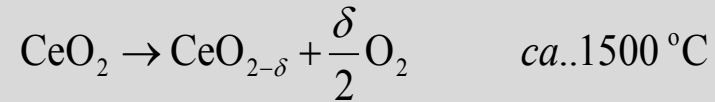
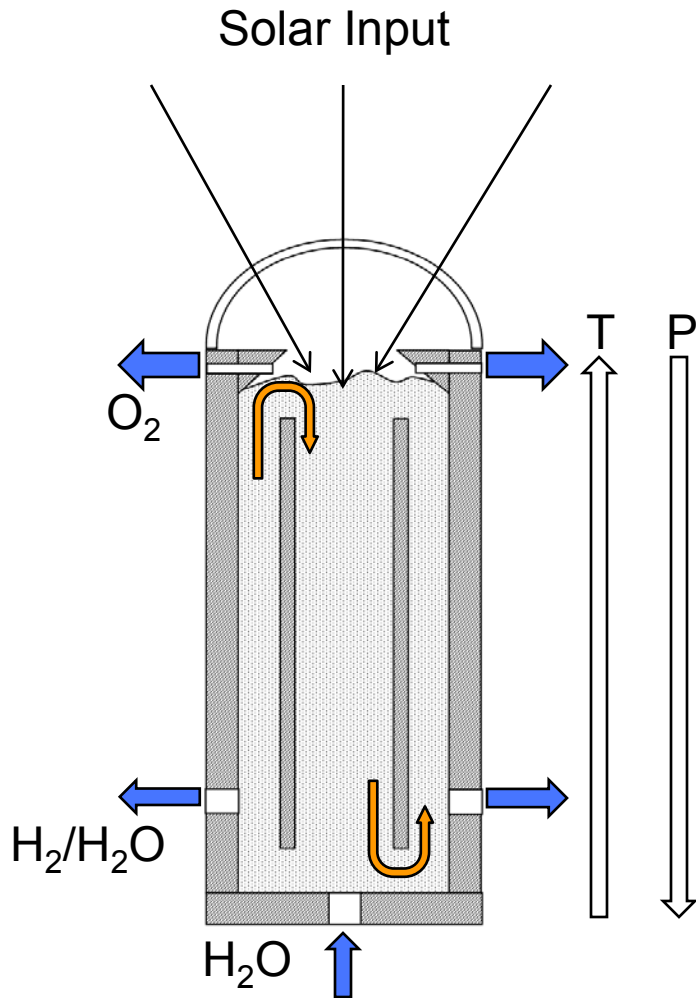

- Direct solar irradiation of the reactive particles (thermal reduction)
- Spatial separation of reaction products (O_2 and H_2)
- Internal pressure separation
- Continuous flow
- Internal heat recovery (recuperation)
- Requires beam down optics

- **Objective:** To develop a particle based thermochemical reactor for efficient solar hydrogen production. The successful development of this reactor will provide a solar interface for most two-step, non-volatile metal oxide cycles that are considered to be among the most efficient solar thermochemical processes.
- **Targets:**
 - \$3/gge at the solar plant gate by 2020 (DOE)
 - System level solar to hydrogen production efficiency ~ 20 % (annual average)
 - Maximizing efficiency is key to reducing costs
- **FY 11 Accomplishments and impact:**
 - Identified a reactor system concept capable of annual average solar to hydrogen production efficiency in excess of 20%
 - Reactor utilizes a particulate reactant to maximize kinetics and avoid issues with mechanical stress/failure
 - Built a test platform suited to the characterization of rapid thermochemical processes (materials development)

Technical efforts target three areas

- Materials Discovery and characterization
 - Evaluate the kinetic and thermodynamic performance space of several reactant systems starting with cerium oxide
- Reactor Development
 - High temperature material compatibility
 - Packed bed solids conveyance
 - Advanced solar optics
 - Prototype
- System Analysis
 - High level performance models used to predict annual average performance
 - Detailed ASPEN flow sheets for reactor optimization

- **Materials Discovery and Characterization**
 - Laser heated reactor is operational: Heating rates of 100°C/s
 - Initial characterization of cerium oxide reduction and oxidation
- **Reactor Development**
 - Performance model has been developed
 - Particle transport properties have been measured (CeO₂ powder)
 - Particle packed-bed conveyor has been designed
 - 10 kW_{th} prototype design underway
- **System Model**
 - Annual average efficiency of a dish-based system has been calculated for a range of conditions

- Reactor model combined with TMY2 meteorological data to estimate hourly performance for an entire year
 - Results are geographically dependent
 - Model enables prediction of annual average efficiency
 - Dish-based reactor system model is complete, towers are next.
- System level model is being ported to Aspen Plus[®] for detailed design and analysis

System Level Performance (2 of 2)

$T_{TR} = 1500^{\circ}\text{C}, T_{OX} = 1000^{\circ}\text{C}$
 $P_{TR} = 100 \text{ Pa}$

↓ Sunlight

Resource eff. = (Resource > 300 DNI) / Resource = **95%** for Daggett

Operational ~ 94%

Equip. Availability = 97%, B&S = 98%, Wind Outage = 99%

Optical ~ 79%

Reflectivity = 93% (two reflections), Dirt = 95%, Window = 95%,
Tracking = 99%, Intercept = 95%

Receiver ~ 82%

Radiation = 82%
Conduction/Convection = 0 %

Solar to Available Heat = 58%

Reactor/Thermochemical ~ 37%
Pumping ~ 96% (100 Pa)

↓ H₂

**Annual Average Solar to
Hydrogen**

Design Point: 21%

Range: 20%-24%

- Cerium oxide powders ($\sim 5 \mu\text{m}$) are the near term reactant
- Much effort has focused on conveying ceria powder within a reactor under the appropriate conditions
 - Solid phase transport of ceria powder has been measured including bulk density, permeability, and wall friction
 - Conveyor conceptual designs have been developed
- Compatibility of ceria powder with alumina and Haynes 214 was experimentally demonstrated to 1400°C
- Models of reactor operation have been developed
 - Recuperation is critical to efficient operation
 - There is room for improvement with respect to the reactive material performance

- Particles can be vertically conveyed using an “Olds” elevator
 - Works for dish and tower platforms
- Steam is used to react, cool, and convey particles
- Models predict potentially high conversion efficiency with recuperation

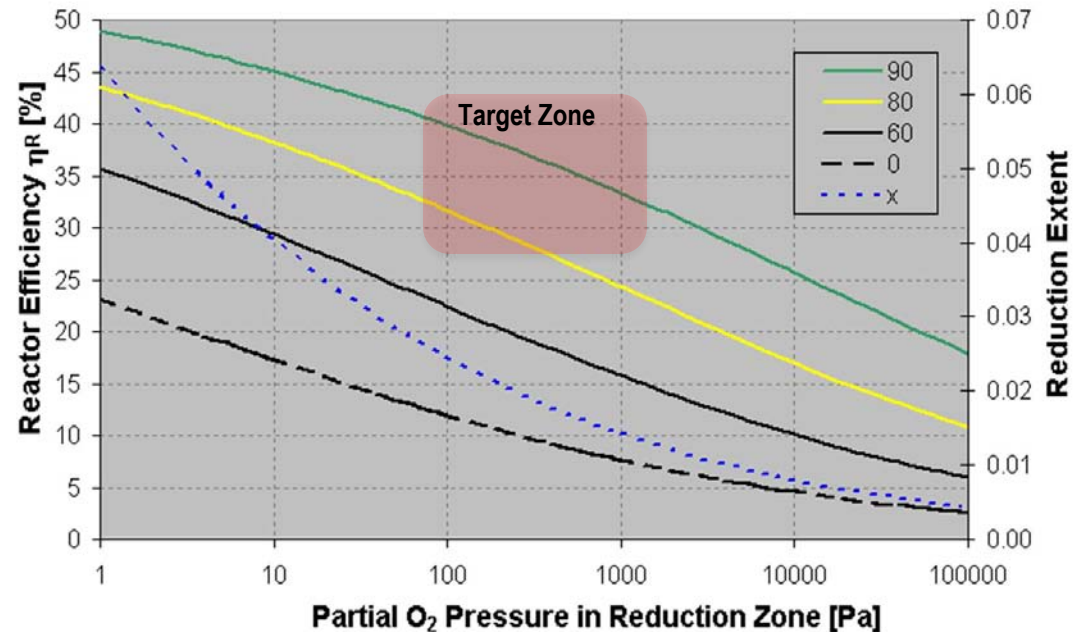
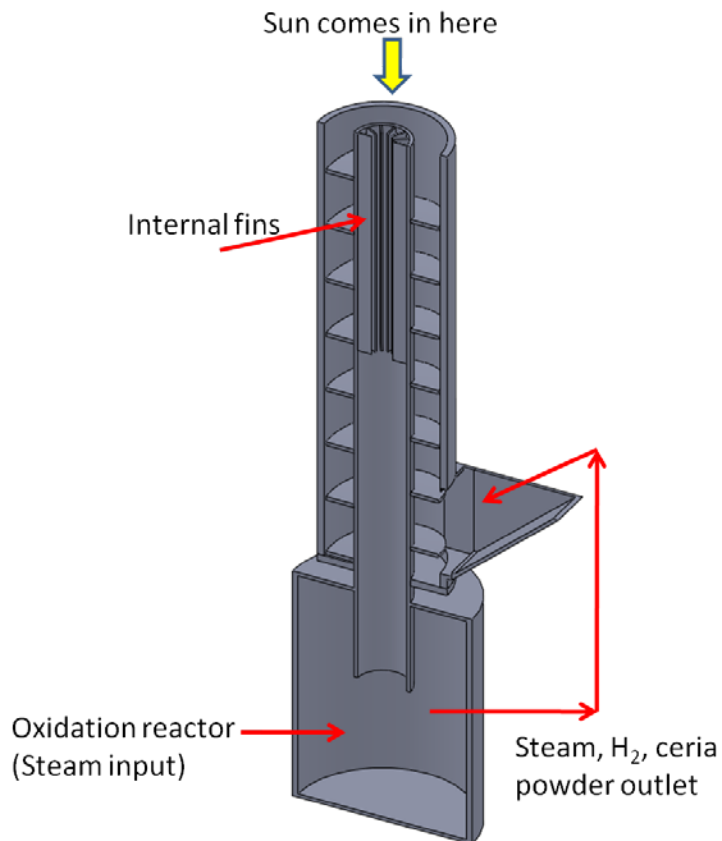

Thermochemical performance for pure cerium oxide reactant powder

- An on-sun prototype of the particle reactor is being designed
 - $T_{TR} = >1400^{\circ}\text{C}$, $T_{OX} < 1000^{\circ}\text{C}$,
 $P_{tot} = 1000\text{-}10000\text{ Pa}$
 - Reactor power input 10 kW_{th} on the solar furnace facility at SNL
 - Target hydrogen production between: 4-20 Liter/min
 - Ceria flow between 20-100 g/s
 - Conveyor and optics design underway

Spectral Reflectance of Second and Front Surface Silvered Reflectors

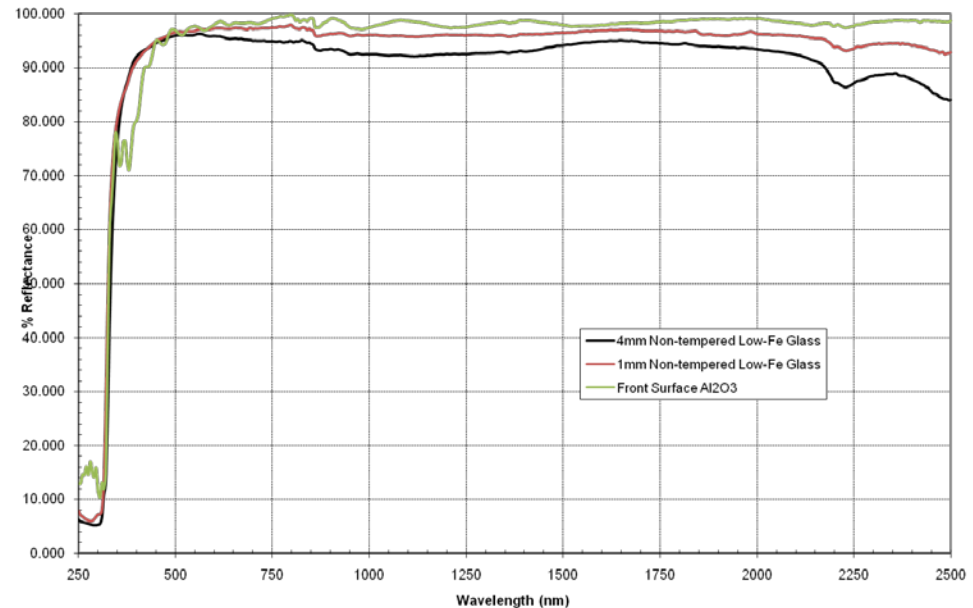

Spectral reflectivity of solar optics. Compound solar reflectivity for the prototype (two reflections) is 93%. Heat load on the second reflector is 0.7 kW, but its non-uniform. Data provided by NREL

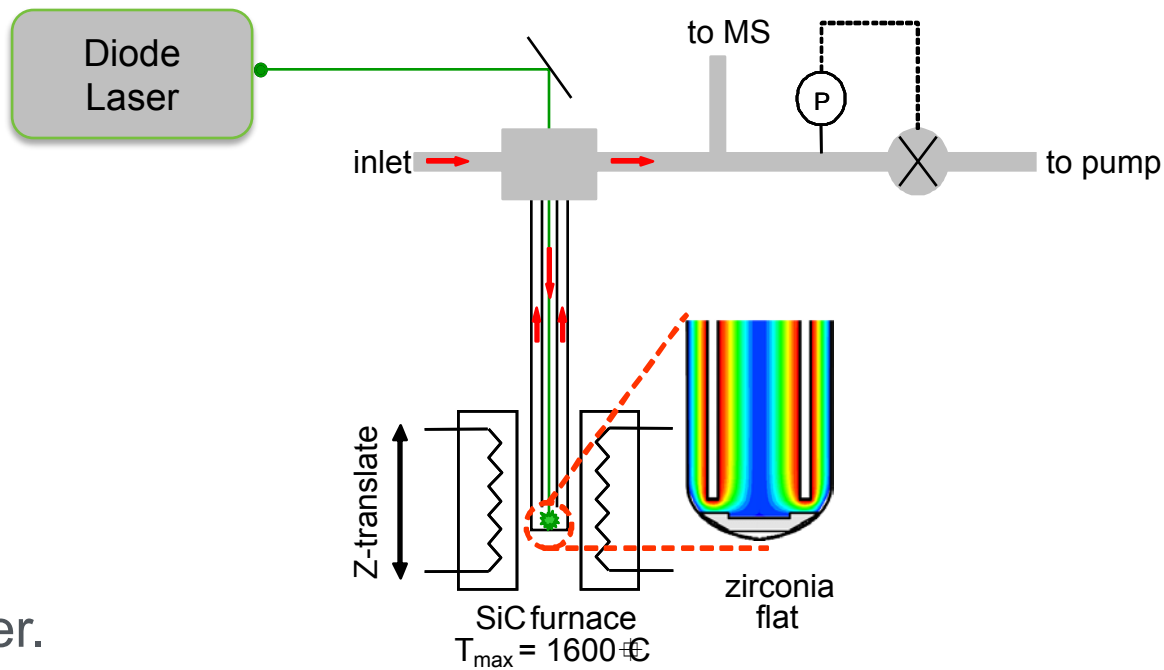
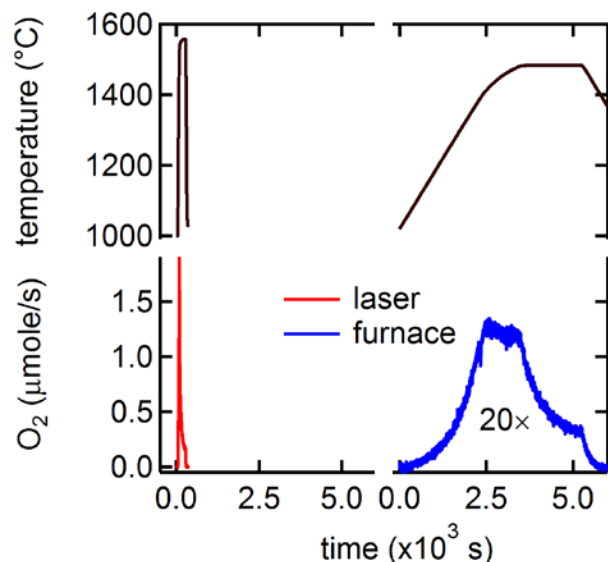

- 500 W CW near IR laser.
 - Achieve heating rates in excess of 100 °C/s.
 - Adjust radiative flux with optics and power control.
 - 0 to >> 5000 suns
- Thermodynamic and kinetic characterizations over a range of conditions
- Investigate thermal reduction.
 - More closely mimic CSP conditions in a “model” environment.

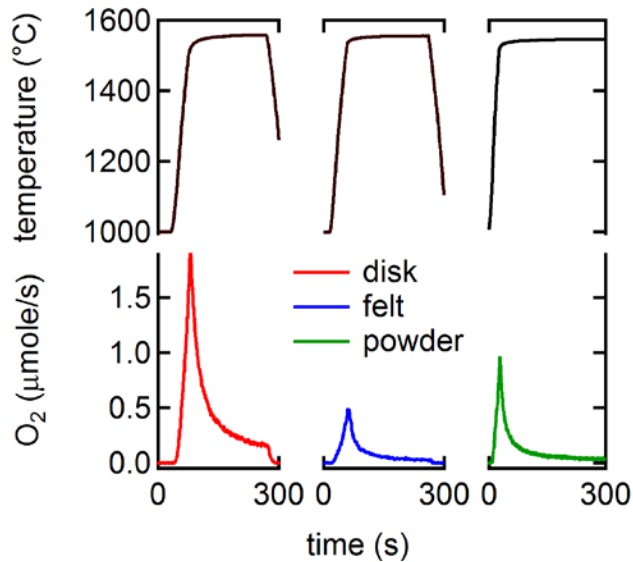

form	mass (mg)	mole O ($\times 10^{-6}$)	δ
disk	960	220	0.0394
felt	207	48	0.0398
powder	454	91	0.0350



felt

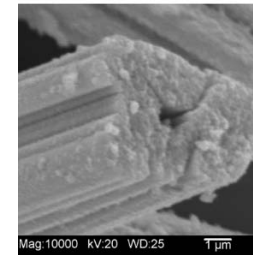

powder

- Disk 1000 μm thick.
- Felt primary fiber diameter $\sim 10 \mu\text{m}$.
- Powder primary particle diameter $\sim 5 \mu\text{m}$.
- Solid-state dynamics at *these length scales and heating rates* do not limit reduction kinetics.
 - Rates scale with mass
 - Thermal conduction, vacancy diffusion, surface chemistry

temperature (°C)	total H ₂ (μmole/g)	peak H ₂ (μmole/s/g)
1200	274	3.27
1100	273	4.76
1000	249	6.51
900	229	4.75
800	235	3.60
700	285	2.64

- Total H₂ produced is nearly constant but peak rates are variable.
 - Material is stable upon cycling
 - no degradation up to 30 cycles
- Detailed kinetic analysis is ongoing.
 - Transition between rate controlling mechanisms evident
 - $T < 1000$ °C and $T > 1100$ °C

Data presented for ceria felt

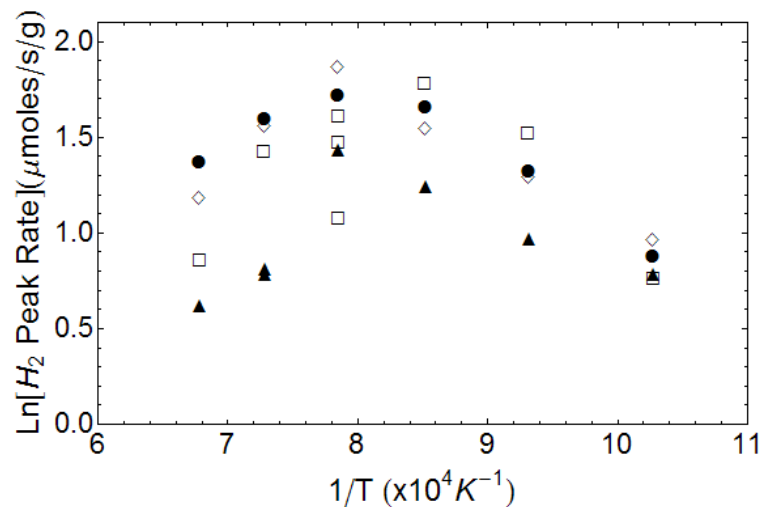
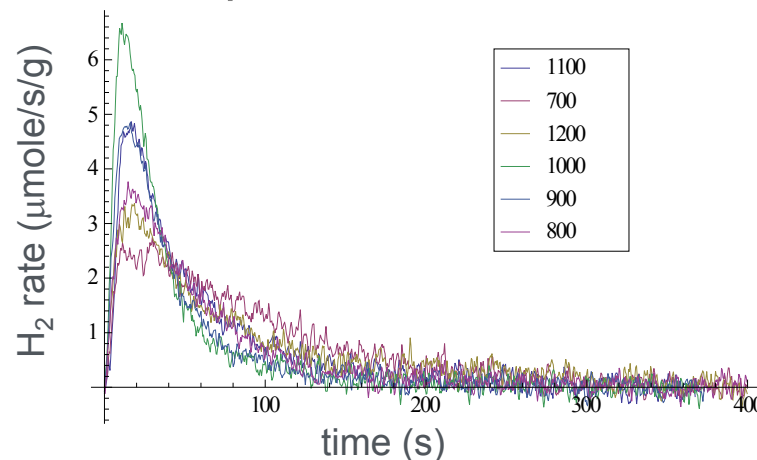

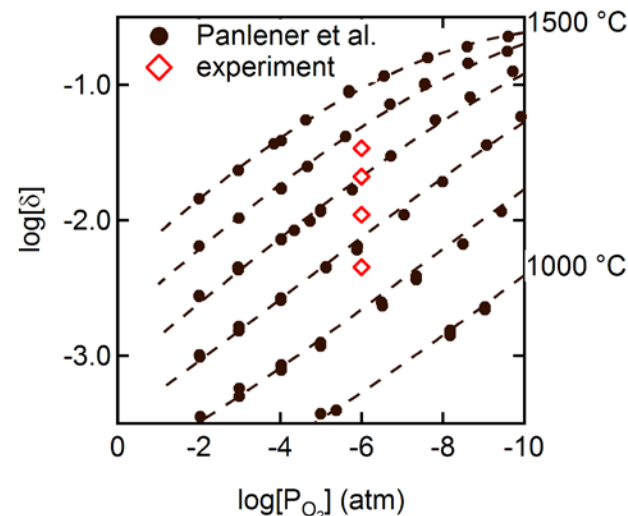
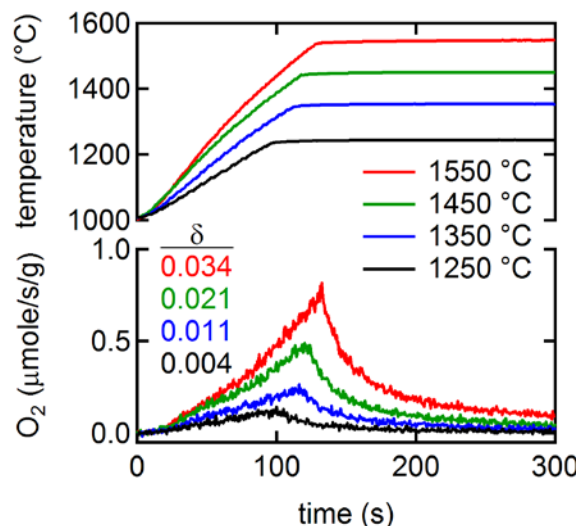
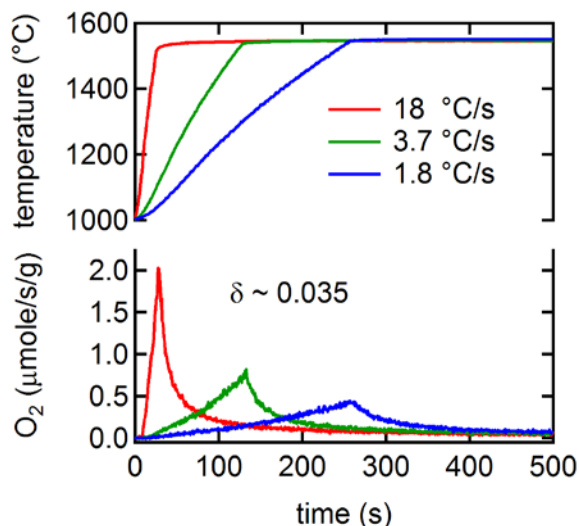

- Varying heating rate and plateau temperature required for kinetic analysis.
 - **Solid-state kinetic theory**
 - Screen for rate limiting mechanisms
 - Evaluate kinetic parameters (activation energy)
- Develop kinetic model for predicting reduction behavior.
- Assess the extent of reduction likely achievable in CSP reactor concepts.

- Currently working with Al Weimer's group at the University of Colorado
 - Several students are working at SNL/CA in the area of materials discovery and characterization
- Jenike and Johanson Inc. are supporting the development of particle conveyor concepts.

- Continue materials characterization and identify more favorable systems
- Build and test a prototype reactor at the solar furnace
 - Additional technical challenges may become apparent during testing
- Perform a detailed design of a central receiver-based reactor.
 - Possibly results in a larger scale prototype
 - Provides a basis for detailed cost assessment

- A new solar thermochemical hydrogen production reactor was designed
 - The reactor has the potential to achieve heat to hydrogen conversion efficiency $\sim 40\%$,
 - $> 20\%$ solar to hydrogen efficiency at 100 Pa (2011 Milestone)
 - Includes all of the key performance attributes of a solar TC reactor
 - Scalable to central receivers
 - 10kW_{th} prototype design is underway
- Materials characterization using a laser heated reactor for evaluation of “realistic” material performance
 - Preliminary reaction kinetics for pure ceria have been measured
 - Full characterization of pure ceria powders in progress
- System models have been developed that predict annual average solar to hydrogen efficiency up to 23%

Thank you for your attention

Questions?