



**University at Buffalo**  
*The State University of New York*



# **Advanced Catalysts and MEAs for Reversible Alkaline Membrane Fuel Cells**

Hui Xu (PI)  
Giner Inc  
Newton, MA

Project ID: FC129

2015 Hydrogen and Fuel Cells Program  
Annual Merit Review and Peer Evaluation Meeting

This presentation does not contain any proprietary, confidential, or otherwise restricted information

# Project Overview

## Timeline

- Project Start Date: June 1, 2015
- Project End Date: May 31, 2017

## Budget

- Total \$1,200,496
  - DOE share \$959,334
  - Contractors share \$241,162

## Collaborators

- SUNY-Buffalo:  
Prof. Gang Wu
- NREL  
Dr. Bryan Pivovar

## Barriers Addressed

- Activity (catalyst; MEA)
- Durability (catalyst; MEA)
- Cost (catalyst; MEA)

## Technical Targets

- Design and develop ORR/OER bi-functional oxide catalysts
- Integrate ORR/OER bifunctional oxide catalysts and alkaline membranes to develop highly efficient reversible alkaline membrane fuel cells (AMFCs) for stationary energy storage

# Comparison of Energy Storage Devices

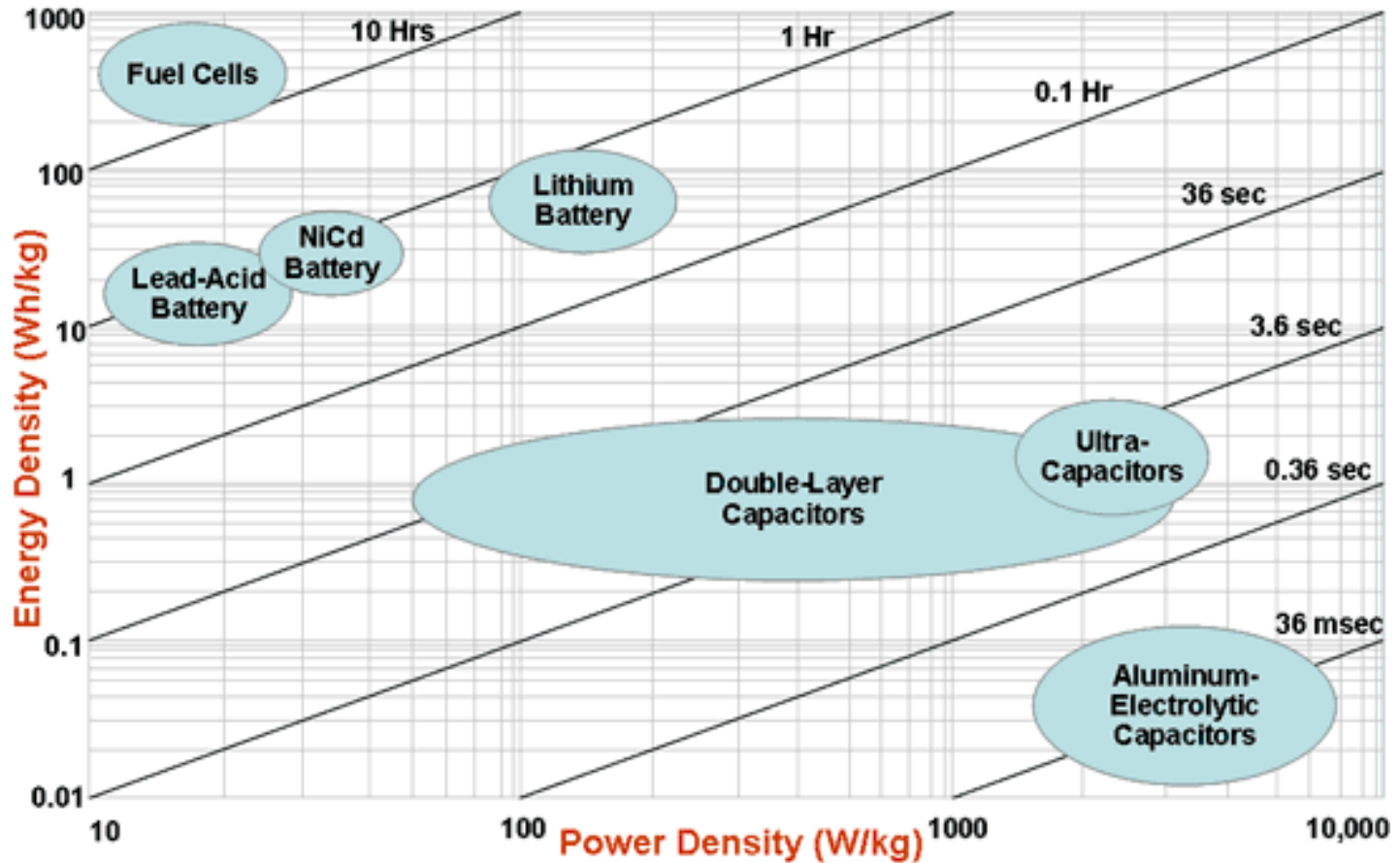

Source US Defence Logistics Agency

<http://www.mpoweruk.com/performance.htm>

Reversible fuel cells may have higher energy density than most batteries

# Reversible Fuel Cells

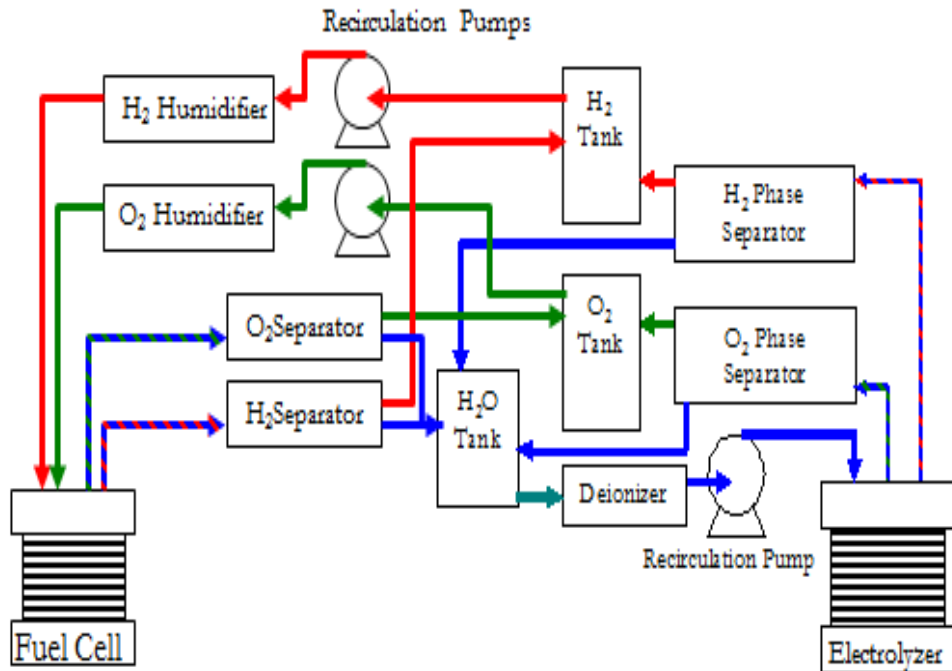

**Giner unitized reversible PEM fuel cell**  
Fast Mode Cycling: 200 mA/cm<sup>2</sup> URFC

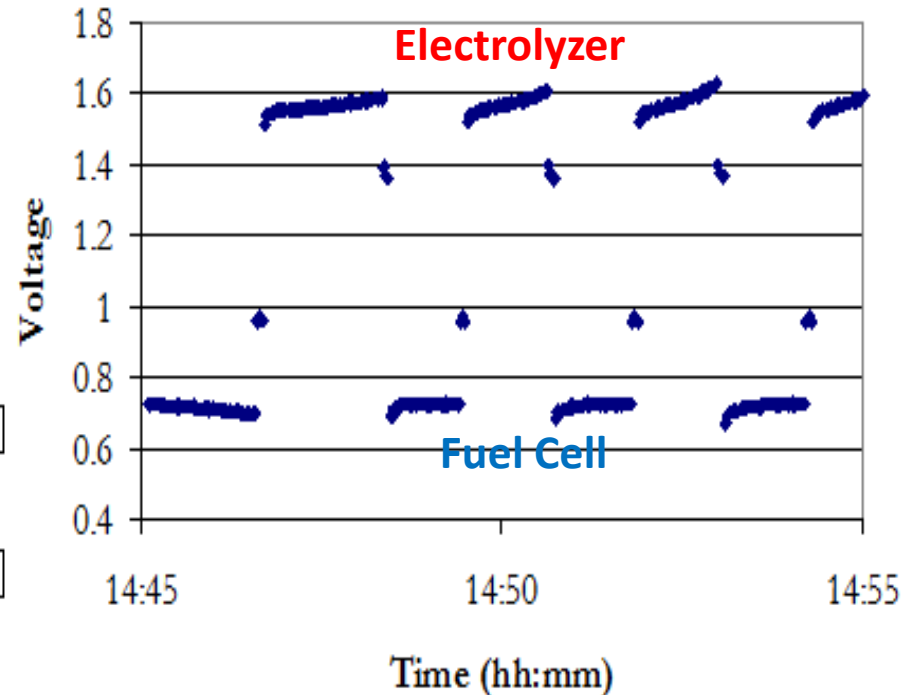

- ◆ Water electrolyzer is an ideal device to store energy from wind mills and solar farms, where surplus (off peak) energy is nearly free
- ◆ Stored H<sub>2</sub> can be used for fuel cells to generate electricity in peak time

# Research Objective

## Opportunities

- Non PGM based catalysts drives down capital cost;
- New concepts for oxide catalyst design;
- Surplus electricity from renewable energy;
- Gradual maturity of AEM technology

## Anion Exchange Membrane (AEM) Fuel Cells

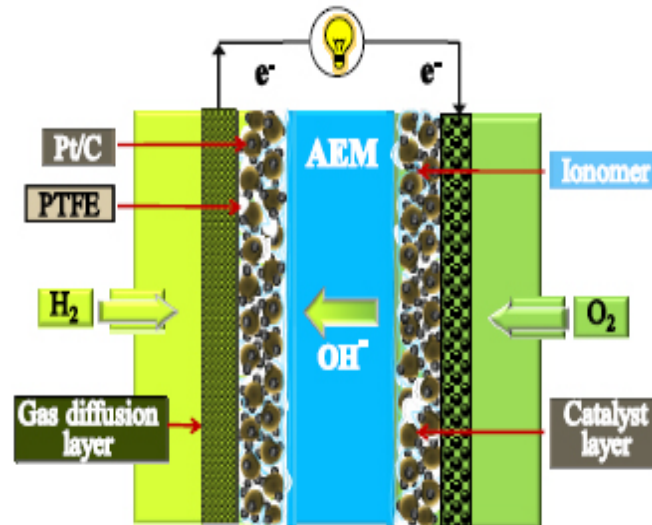

## Challenges

- Non-PGM bi-functional oxide catalyst **activity** and **stability**
- Fabrication of non-PGM MEAs for AEM fuel cells NOT extensively studied
- Unitized regenerative fuel cell design and construction

**Integrate AEM water electrolyzer and fuel cell together to develop reversible AEM fuel cell for energy storage and conversion**

# Technical Approaches

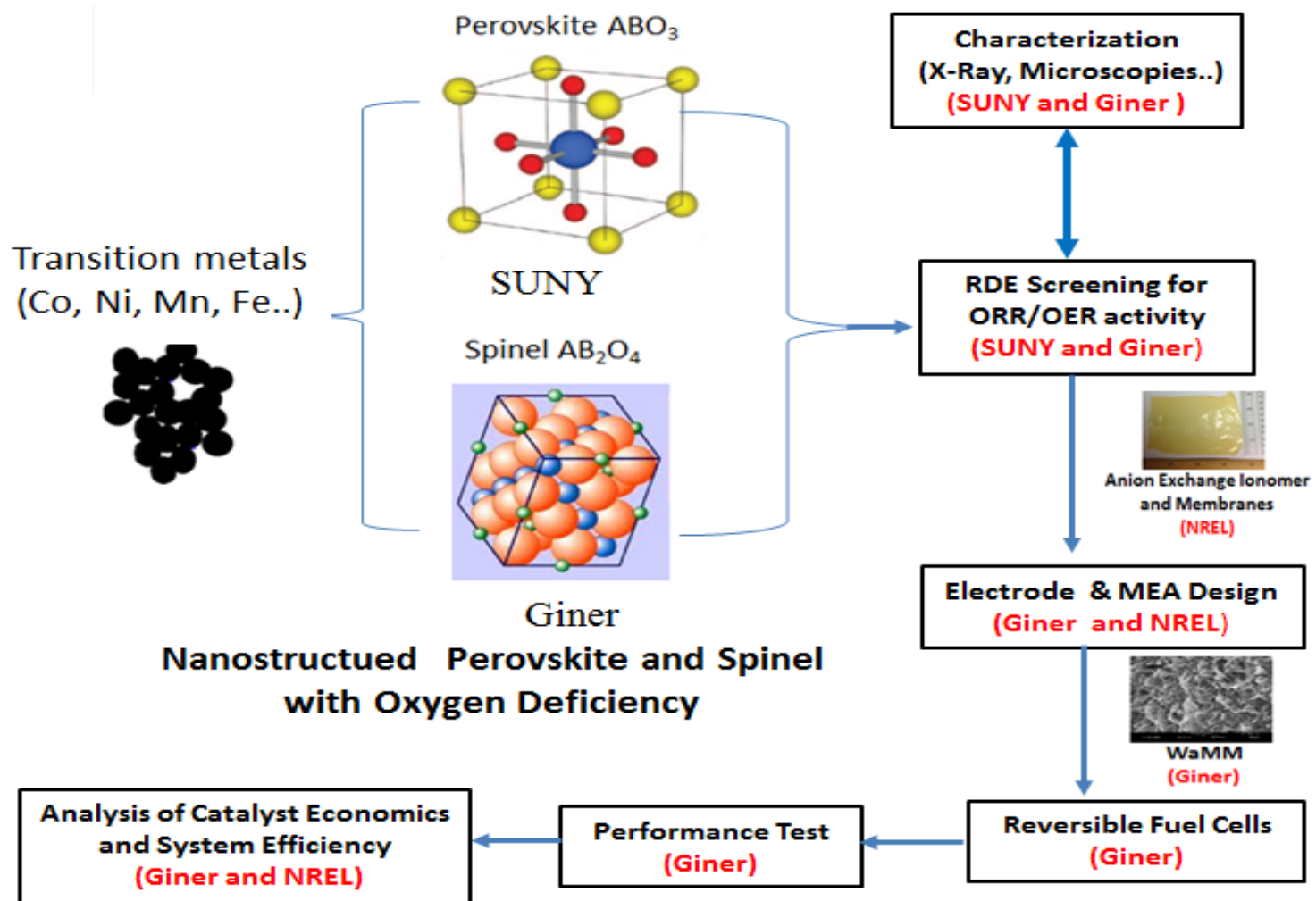

- Catalyst Long-term Stability;
- MEA Fabrication Technology

# Performance Schedule

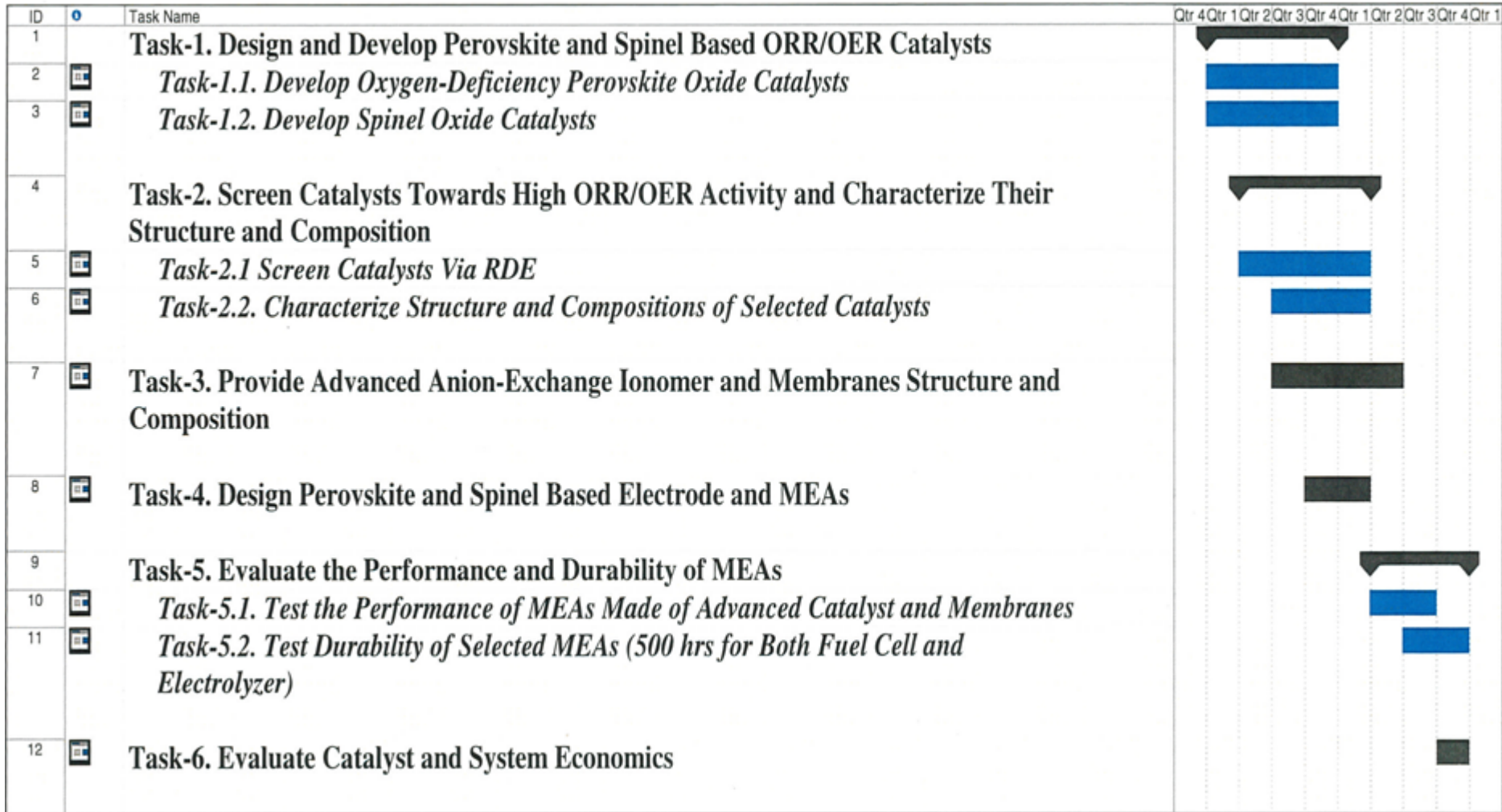



# Task 1-1: Design Perovskite ORR/OER Catalysts (SUNY)

## Oxygen-Deficient $h$ -BaTiO<sub>3-x</sub>

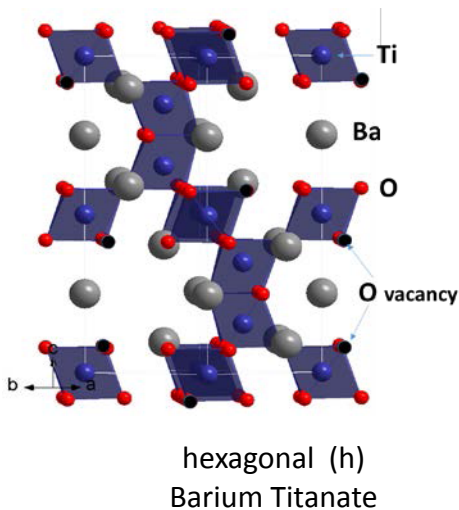

## ORR/OER Activity

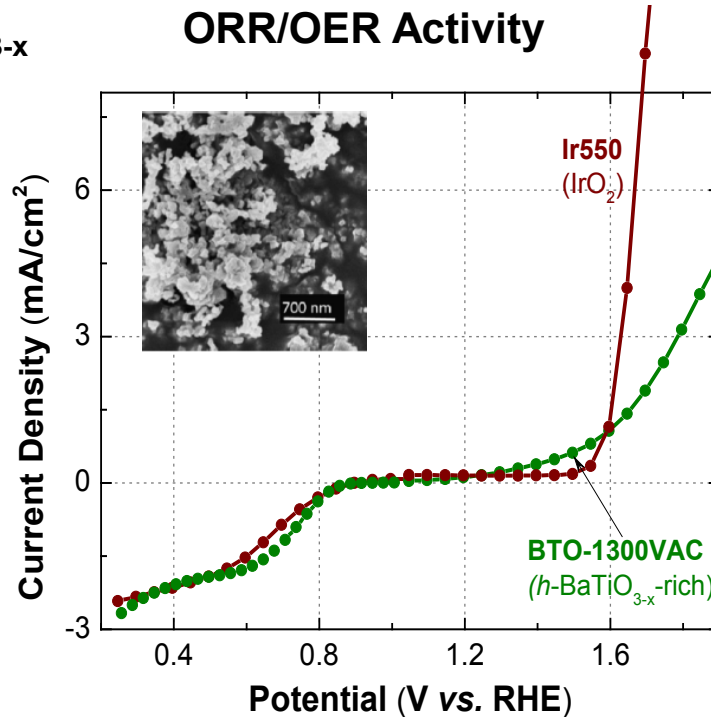

## Vacuum Furnace



- Perovskite oxide catalysts have emerged as the most promising bifunctional ORR/OER catalysts
- Controlled oxygen vacancies in the perovskite crystal structure by varying vacuum degrees and temperatures will maximize catalytic activity along with stability



# Task 1-2: Develop Spinel ORR/OER Catalysts (Giner)

Two categories of nanostructured spinel oxides:  $\text{CoFe}_2\text{O}_4$  and  $\text{M}_x\text{Co}_{1-x}\text{Fe}_2\text{O}_4$  (M could be Cu, Ni, Mn or other metals)

Spinel Structure

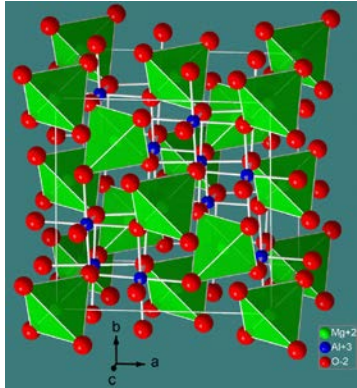

Giner High-energy Ball Mill

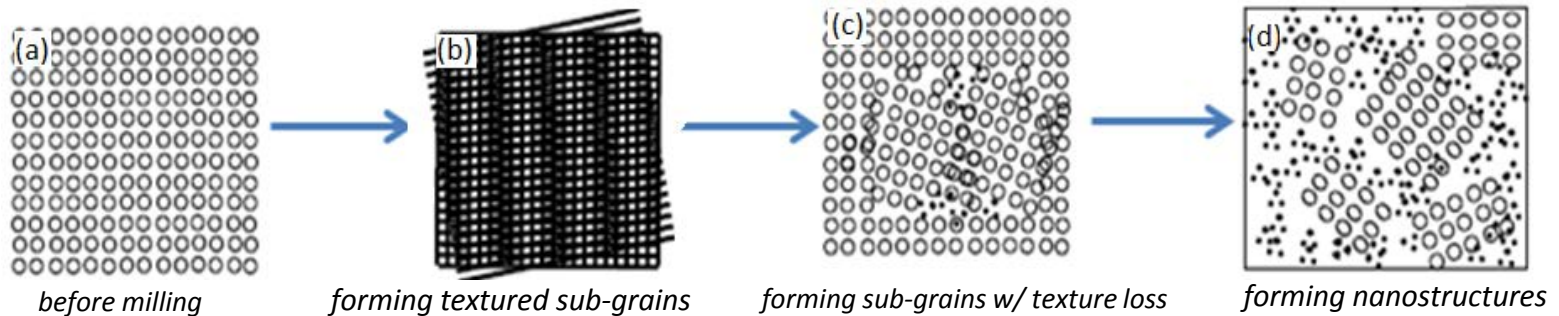

Liu, B., Ph. D thesis, NATIONAL UNIVERSITY OF SINGAPORE (2008)

- **Composition and ball milling process conditions will be varied to achieve optimized activity and stability**

## Task 2: Screen Catalysts and Characterize their Structure and Composition (Giner and SUNY)

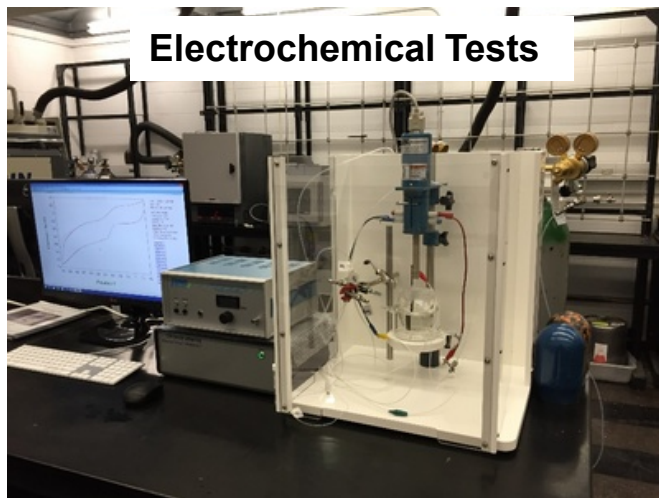

Techniques to be used	Information to be gained
XRD	Particle size and crystal structure
SEM	Catalyst morphology
TEM	Catalyst structure and particle size
XPS	Catalyst surface species

- The synthesized catalysts will be first screened by rotating disk electrode (RDE) for the ORR and OER activity in alkaline solution
- Oxide based catalysts will be extensively characterize to establish the correlation of synthesis-structure-properties

# Task 3: Provide Advanced Anion Exchange Ionomer and Membranes (NREL)

Reaction scheme developed to synthesize novel PF AEMs (left). PF-FP is the sulfonyl fluoride precursor (right).

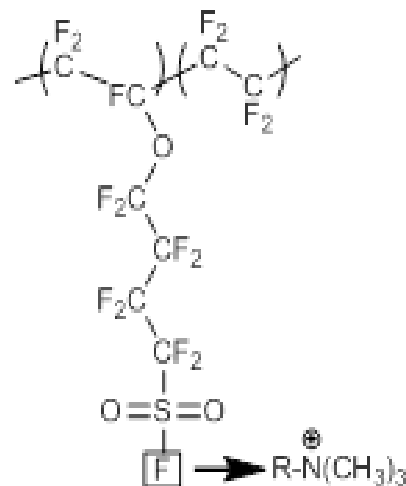
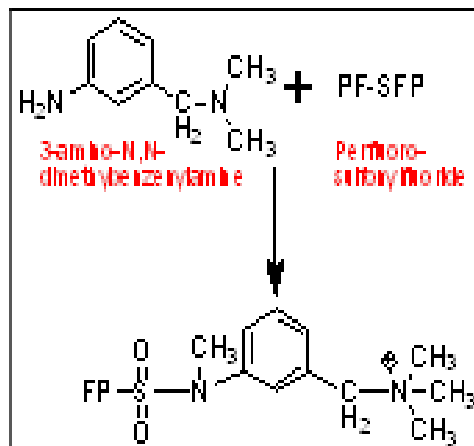

R	Linkage	DFT Hydroxide Stability (kcal/mol)		
		Benzyl CH <sub>2</sub>	Ammonium CH <sub>3</sub>	β elimination
	Amide	NA	24.7	19.7
	Amide	23.4	24.5	NA
	Aryl	22.1	24.1	NA

- NREL has substantial experience in developing components of AMFCs.
- Integrate advanced catalysts with novel ionomers at developed NREL

## Task 4: Design Perovskite and Spinel-Based Electrode and MEAs (Giner and NREL)

Use Giner's proprietary water management membrane (WaMM) to build reversible fuel cells

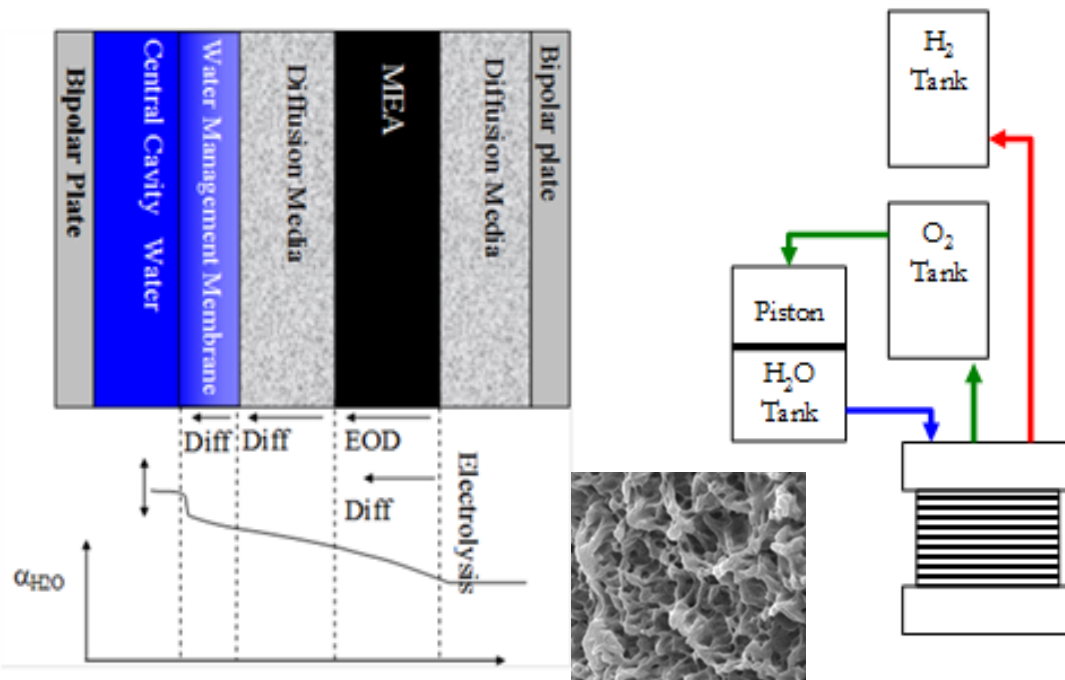

- MEA design using perovskite or spinel catalysts
- Compatibility between catalyst and anion exchange ionomers (catalyst wettability and dispersion)

**Advantages of WaMM-based static feed electrolyzer:**

- Since no liquid water is involved, water-flooding will be mostly minimized;
- No gas/water separators required to improve simplicity/reliability of fuel cells;
- Only using water vapor mitigates the effect of impurity of water

# Task 5: Evaluate the Performance and Durability of MEAs (Giner)

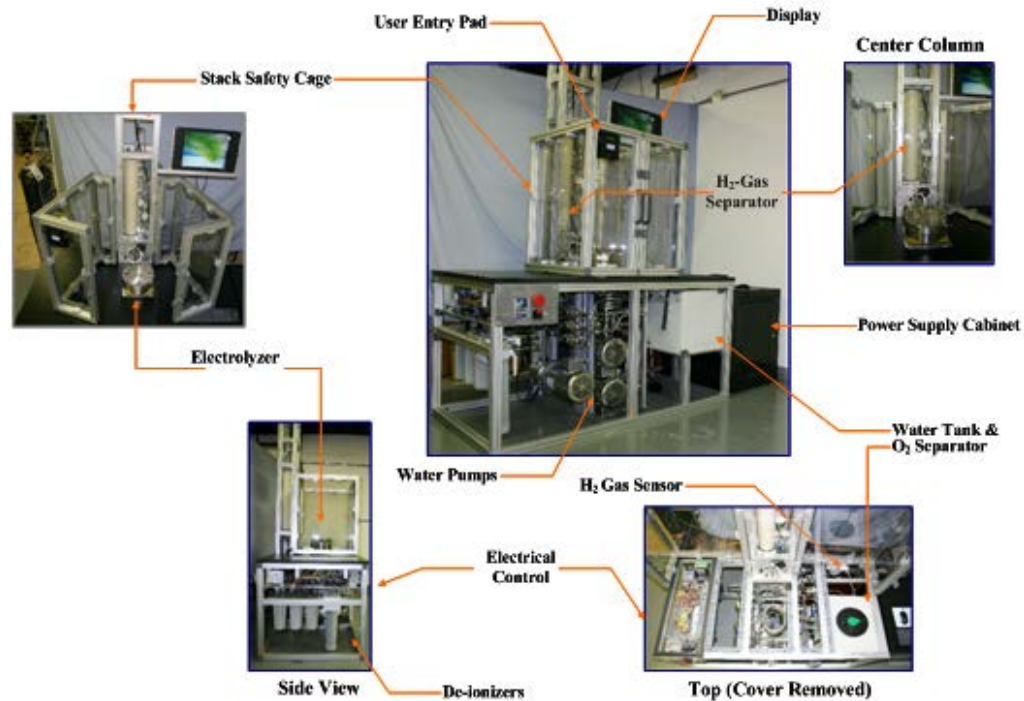

## Performance Test

- Polarization curves
- HFR resistance
- Membrane crossover

## Durability Test

- Voltage cycling
- Constant current density of 600 mA/cm<sup>2</sup> for 1000 hours

## **Task 6: Evaluate Catalyst and System Economics (Giner +NREL)**

- **Cost of all catalysts will be analyzed in the context of a small-scale, short production as well as a commercial mass production.**
- **Cost of fuel/electrolyzer system will be analyzed. The analysis will take into consideration factors including materials cost, labor, and facilities.**
- **The effect of OER/ORR catalysts on the system efficiency (round-trip efficiency) will also be evaluated.**

# Milestones

Time	Milestone Description
Q1	Synthesize BaTiO <sub>3-x</sub> perovskites with 3 different oxygen vacancy concentrations
Q2	Prepare 3 other oxygen-deficient AA'BB'O <sub>3-x</sub> multiple perovskite catalysts (e.g., BaSrCoFeO <sub>3-x</sub> or BaSrMnCrO <sub>3-x</sub> ) with optimized defect structures
Q3	Reduce perovskite particle size to nanoscale (<10 nm) with much increased surface areas (>20 m <sup>2</sup> /g)
Q3	Prepare 3 A <sub>x</sub> B <sub>1-x</sub> C <sub>2</sub> O <sub>4</sub> spinel catalysts (A, B and C represent Co, Mn, Fe or other Metals) with particle size <10nm
Q4 (go/no-go point)	In RDE, demonstrate ORR activity > 1 mA/mg oxide at IR-free 0.9 V; and OER activity > 15 mA/mg oxide at IR free 1.6 V.
Q4	Provide 20g of PF AEM material in membrane/ ionomer form Membrane conductivity >0.05 S/cm at 60°C and 100% RH; H <sub>2</sub> permeability: 10 <sup>-12</sup> mol/(kPa.s.cm)
Q5	3 AEI ionomer categories and 5 ionomer loadings will be evaluated to identify the best electrode composition
Q6	Achieve RFC performance 0.55V for fuel cell and 1.6V for electrolyzer, both at 600mA/cm <sup>2</sup>
Q7	Achieve fuel cell and electrolyzer life of 500 hours with less than 10% performance decay
Q8	Generate a full report of catalyst and reversible fuel cell economics



# Acknowledgments

- Financial support from DOE EERE Fuel Cell Technologies Office, Incubator Program Award # DE-EE0006960
- DOE program manager
  - Dr. David Peterson
  - Donna Ho
- Giner Personnel
  - Corky Mittelsteadt and Brian Rasimick
- SUNY: Prof. Gang Wu
- NREL: Dr. Bryan Pivovar