

MT011

Ground Support Equipment Demonstration

Jim Petrecky

This presentation does not contain any proprietary, confidential, or otherwise restricted information.

OVERVIEW
RELEVANCE

Program Overview

Cargo Tractor Demonstration Program



Timeline

- Project Start Date | 1/1/13
- Project End Date | 3/31/17
- Percent Complete | 76%

Barriers

- Exposure to elements
- Airport emissions
- Aggressive load profile

Budget

- Total Funding | \$4.996M
- DOE Share | \$2.497
- Partners Share | 50.03%
- Funding in FY15 | \$0
- Funding in FY16 | \$462k

Partners

- Plug Power
- FedEx Express
- Charlotte America
- Memphis-Shelby AA
- Memphis Fire Services



• 15 fuel cell cargo tractors

• Memphis airport for 2 years

• H2 station on airport ramp

A real economic alternative to diesel assets

- Value prop that makes sense
- Readily available fuel
- Service organization to maintain asset operation
- Supply chain to provide parts to maximize uptime

while
meeting

Dept. of Energy Objectives

- Higher energy efficiency
- Lower petroleum demand
- Lower carbon emissions
- Lower energy expenditures

Value Prop Drivers

- Energy efficiency: 45% efficient fuel cells
- Energy recovery via regenerative braking: 25% recovery
- Decreased maintenance costs
- Decreased fuel costs

Ancillary Benefits

- Ability to evaluate how EV tractors are being used
- Ability to identify misuse to prevent increased failures

Market Drivers

- Clean - zero emissions
- Less noise
- Operational flexibility - no downtime due to exhaust system regeneration
- Cost of compliance o EPA Tier 4 Final standards

Hydrogen Economics



Supply Method	Comments	Price (\$/kg) Fuel Only	Trucks	Usage (kg/mo)	Price (\$/kg) Fuel + Infra
Gaseous	- Inefficient, generally lower volumes (200 kg) - Generally lower pressure (2400 PSI), partial fills	\$12.00	5	800	\$15.75



Supply Method	Comments	Price (\$/kg) Fuel Only	Trucks	Usage (kg/mo)	Price (\$/kg) Fuel + Infra
Liquid	- 20x more efficient than gaseous tube trailers - Liquid tanks can hold ~4,000 kg	\$4.00	100	16,000	\$5.25



Supply Method	Comments	Price (\$/kg) Fuel Only	Trucks	Usage (kg/mo)	Price (\$/kg) Fuel + Infra
Onsite	- Eliminates delivery (40-60% of cost)	\$2.00	500	80,000	\$2.50

Energy Required

Shift Power	Efficiency	Fuel Required	Fuel Required	Fuel Cost	Fuel Cost
kW-hr	%	kW-hr	Units of Fuel	\$/Unit	\$/Shift
50	Fuel Cell		H2 kg	\$/kg	
	45%	111	3.3	\$5.25	\$17.50
	Diesel Engine		Diesel gal	\$/gal	
	20%	250	6.6	\$2.27	\$14.95

However...

- When a diesel tractor needs to stop, mechanical brakes are applied to stop it. The energy dissipates as heat and costs a fair amount in maintenance to change brake pads.
- When an electric vehicle needs to stop, the electric motor can stop the vehicle while changing a portion of that kinetic energy to stored electrical energy.

With 25% Regeneration

Shift Power	Efficiency	Fuel Required	Fuel Required	Fuel Cost	Fuel Cost
kW-hr	%	kW-hr	Units of Fuel	\$/Unit	\$/Shift
50	Fuel Cell		H2 kg	\$/kg	
	45%	83	2.5	5.3	\$13.13
	Diesel Engine		Diesel gal	\$/gal	
	20%	250	6.6	2.3	\$14.95

Energy Required

Shift Power	Efficiency	Fuel Required	Fuel Required	Fuel Cost	Fuel Cost
kW-hr	%	kW-hr	Units of Fuel	\$/Unit	\$/Shift
50	Fuel Cell		H2 kg	\$/kg	
	45%	111	3.3	\$2.50	\$8.33
	Diesel Engine		Diesel gal	\$/gal	
	20%	250	6.6	\$2.27	\$14.95

However...

- When a diesel tractor needs to stop, mechanical brakes are applied to stop it. The energy dissipates as heat and costs a fair amount in maintenance to change brake pads.
- When an electric vehicle needs to stop, the electric motor can stop the vehicle while changing a portion of that kinetic energy to stored electrical energy.

With 25% Regeneration

Shift Power	Efficiency	Fuel Required	Fuel Required	Fuel Cost	Fuel Cost
kW-hr	%	kW-hr	Units of Fuel	\$/Unit	\$/Shift
50	Fuel Cell		H2 kg	\$/kg	
	45%	83	2.5	\$2.50	\$6.25
	Diesel Engine		Diesel gal	\$/gal	
	20%	250	6.6	\$2.27	\$14.95

Expansion of GSE Inventory

US Airline GSE Market			
Type of Equipment	Units	% of Market	Cumulative
Tow Tractors	27,978	45%	45%
Belt Loaders	12,395	20%	65%
Pushback Tractor	6,068	10%	75%
Ground Power Unit (GPU)	4,591	7%	82%
Cargo (Container) Loader	4,493	7%	90%
Airstarts	2,526	4%	94%
Other	3,859	6%	100%
Total GSE Market	61,910	100.0%	

Belt Loaders

Loads from ground level to aircraft storage areas by way of conveyer belt



Pushback Tractor

Pushes airplane backwards away from the gate



Ground Power Unit

Supplies power/air conditioning to the aircraft while at gate or during loading



Container Loader

Loads containers from ground level to aircraft by lifting via a platform



Airstart

Provides the initial rotation to start gas turbine engines



Development of a H2 Ecosystem



Phase 2: Tethered Local Fleet

- Busses/Shuttles
- Delivery (Package, food, etc.)
- Service Vehicle
- Postal Trucks
- Dispensing

Phase 3: Tethered Regional Fleet

- Busses
- Delivery
- Taxis
- Fleet Vehicles
- Cars
- Dispensing

Phase 1: Captive Fleet

- **Tractors**
- Cargo Loaders
- Belt Loaders
- Fork Lifts
- People Movers (Golf Carts, Busses)



Develop a comprehensive plan and roadmap to fund, develop and implement a **repeatable** expansion of hydrogen fuel and mobile and stationary power applications for a regional deployment.

COORDINATION

Program Team

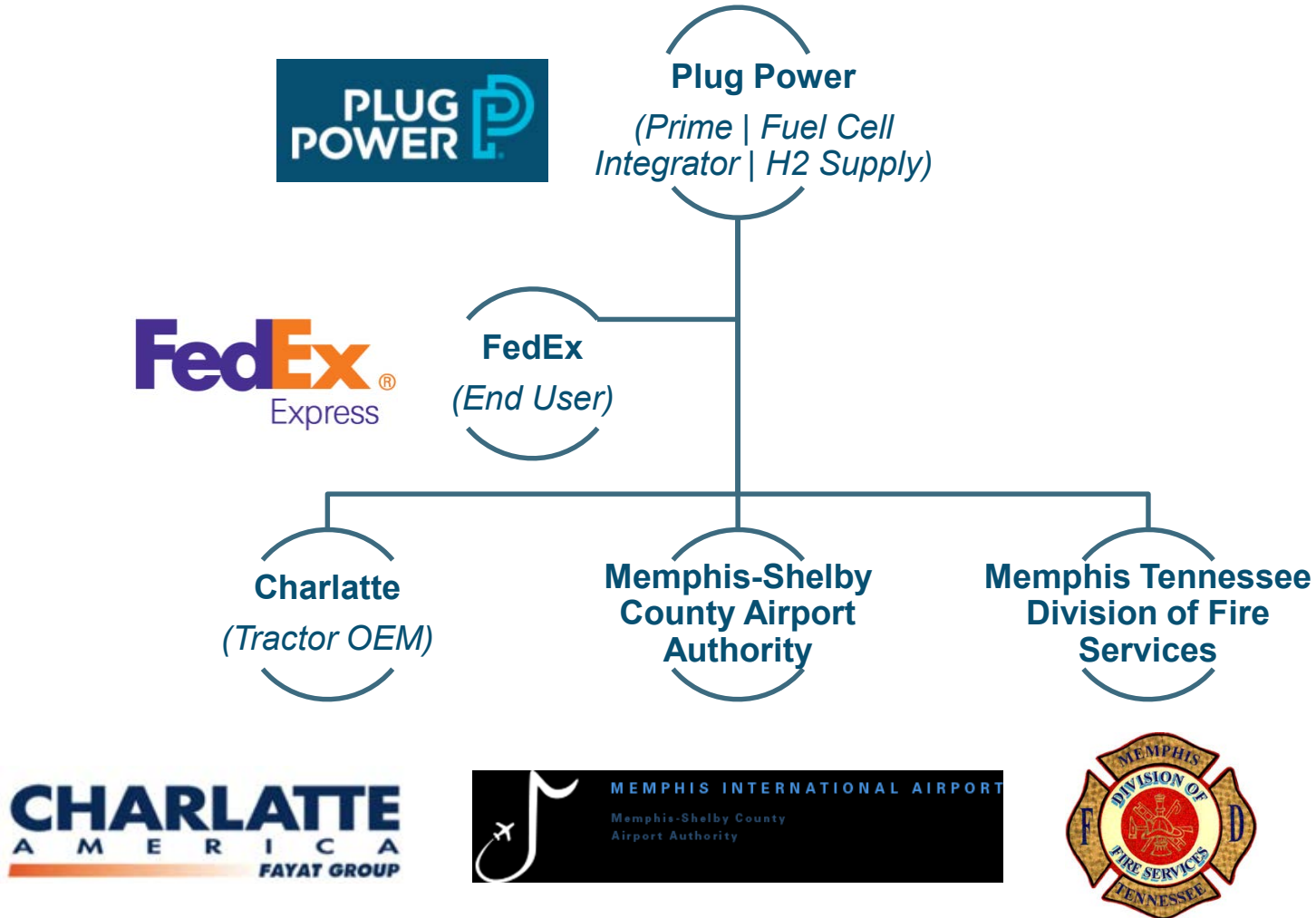

APPROACH

Vehicle Testing

- Testing in Latham
- Charlotte CT5E tractor
- FedEx Express dollies
- Shock testing in Memphis

Route Simulations

- Worst case start/stop

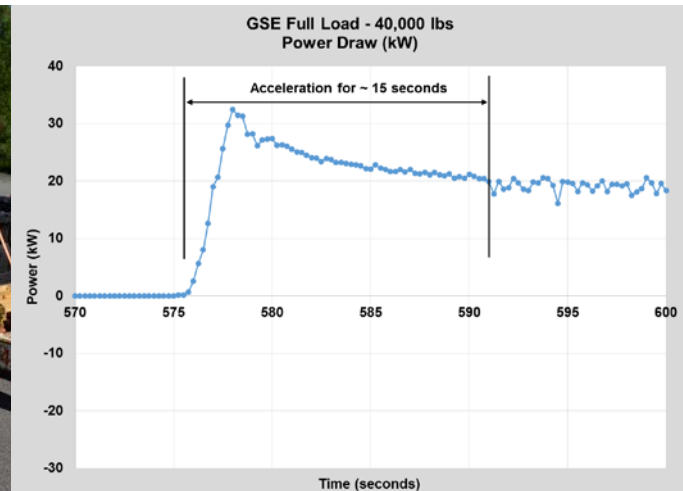
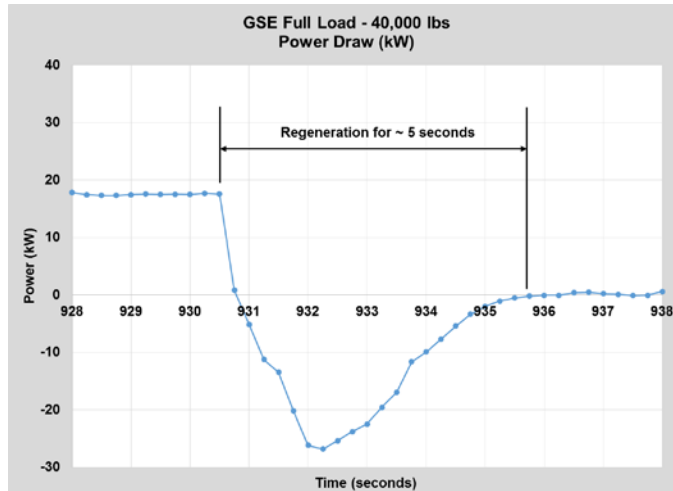
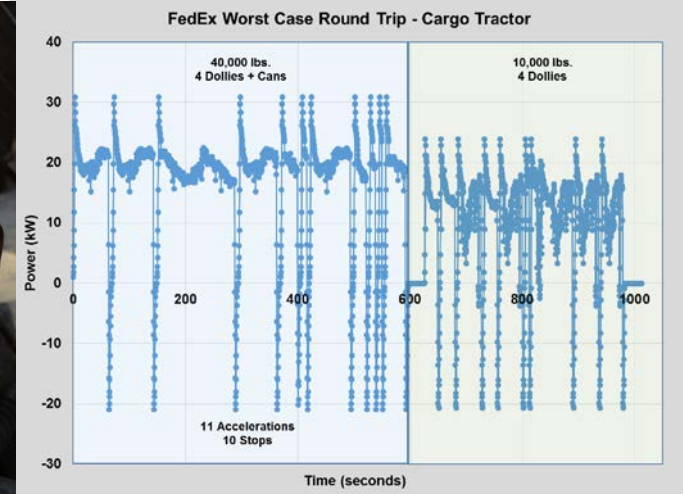

Drop-in-Place Replacement For Battery

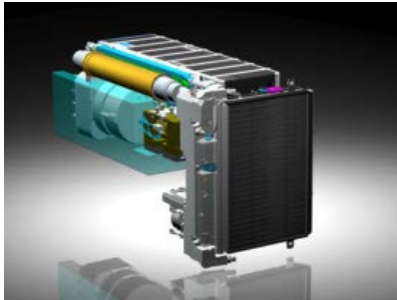

Fuel Cell

- Stack (power)
- Battery (transient soak)

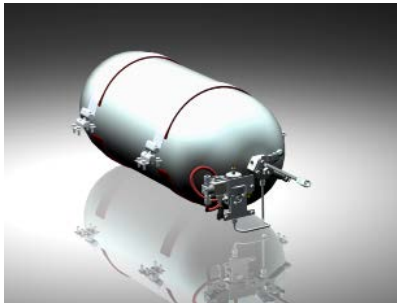

H2 Tank

- Energy (run time)

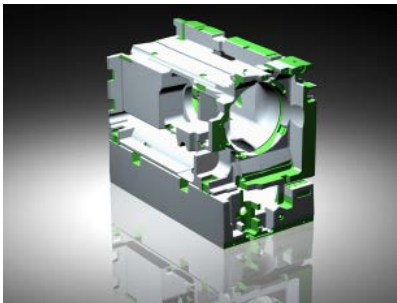

Ballast

- Weight (traction)



GenDrive Specs

- Drawbar: 5,000 lbs.
- Towing Capacity: 40,000 lbs.
- Voltage: 80VDC
- Power: 22 kW
- 100% Outdoor Operation
- H2 Storage: 3.6 kg
- Hybrid PEM FC / Li-Ion Battery Arch.
- 4,000 lbs.

Activated Carbon Filter

- Donaldson adsorption filter
- Removal of oil, hydrocarbon and vapors
- Removal of particulate contamination in the air stream

No evidence of effect on systems during operation



Airport Emissions		
Constituent	Constituent	How Created
Carbon Dioxide	CO ₂	Product of hydrocarbon (jet fuel / diesel / gasoline)
Nitrogen Oxide	NO _x	Product of when air (nitrogen / oxygen) passes through high temp/pressure combustion
Hydrocarbons	HC	Product of incomplete fuel combustion (aka volatile organic compounds (VOCs))
Carbon Monoxide	CO	Product of incomplete combustion of carbon in fuel
Sulfur Oxides	SO _x	Produced of sulfur in hydrocarbon fuels combining with oxygen from air during combustion
Particulates	Particulates	Product of incomplete combustion
Ozone	O ₃	Product of reaction of VOCs and NO _x in the presence of heat and sunlight

Hydrogen Infrastructure

Best scalable, economic solution | Delivered liquid hydrogen

- H2 Capacity: 15,000 gallons
- Liquid temp: -253 deg C
- Liquid Pressure: 5 PSI
- Gaseous Storage: 60 kg
- Gaseous Fueling Pressure: 350 bar
- Dispensing Time: 1 kg/min



Liquid Storage

Liquid Pumps

Vaporizer

High Pressure
Storage

Dispensers

Refueling

- Turn handle on hose until arrow is pointing away from vehicle
- Place hose on fuel cell fueling receptacle
- Turn handle 180 deg. clockwise until arrow is pointing at the vehicle
- Fueling hose locks and automatically starts flow to the tank



GenDrive Install Base Growth

- **Safety Documentation**
 - GSE System Requirements Document
 - GSE Safety Concept
 - Answers to PNNL Hydrogen Safety Team review
 - DFMEA on all subsystems
 - Safety HAZOP
- **Safety Testing**
 - Battery vibration
 - System vibration
 - Hydrogen ventilation testing
 - Hydrogen tank testing (1.25x working pressure)
 - Factory Acceptance Testing (FAT)
- **Fueling Safety**
 - Switches in receptacles to prevent drive-aways
 - Protective housing for receptacle
- **Training**
 - Safety – FedEx fire department
 - Operator
 - Service

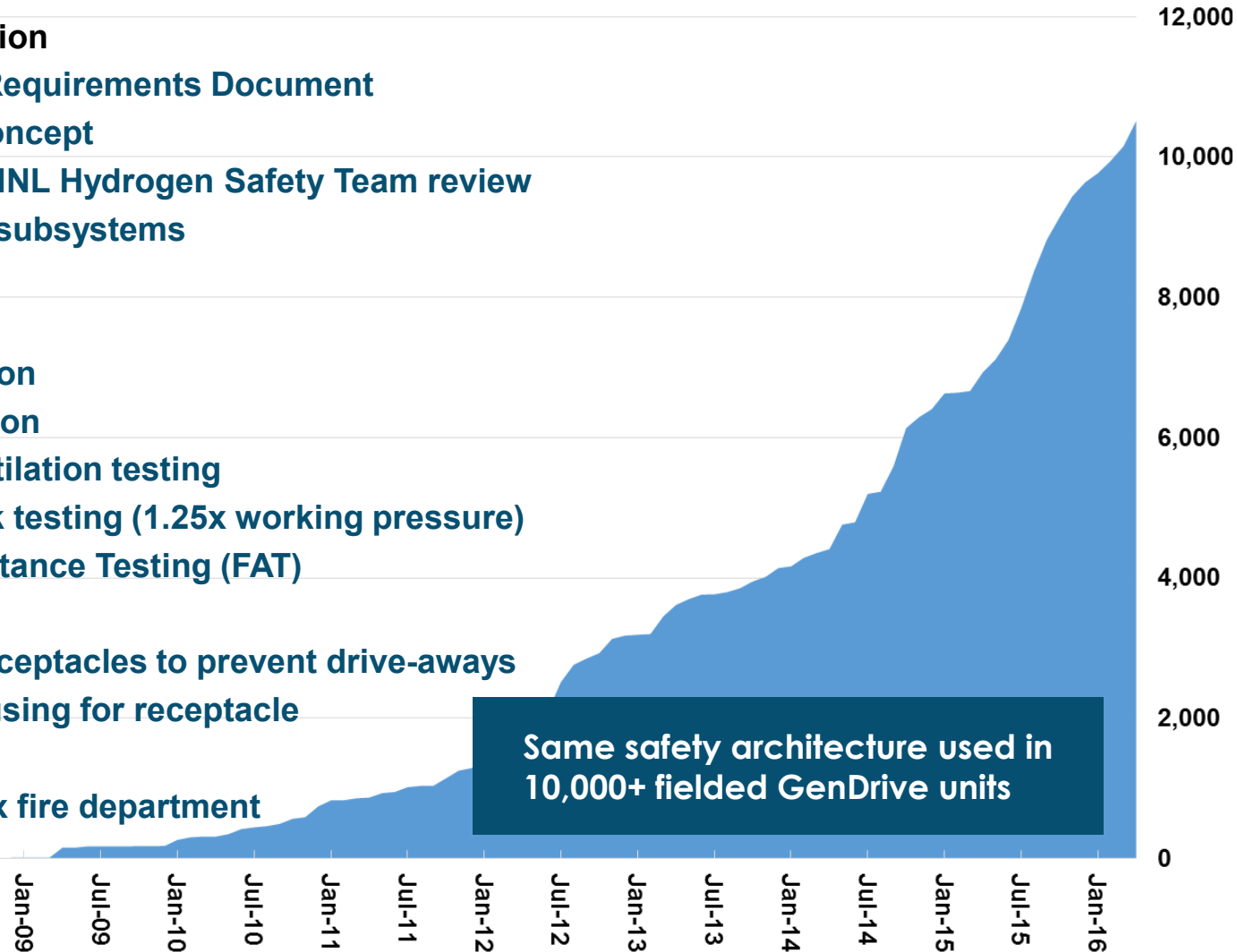

Same safety architecture used in 10,000+ fielded GenDrive units

H2 Infrastructure Safety

- GenFuel safety documentation
- GenFuel service manual
- 3rd party review of infrastructure
- GenFuel System Components
 - Infrared flame detectors
 - Hydrogen sensors in dispenser
 - E-stops
 - Pressure relief valves
 - Pressure relief routes to vent stack
 - Burst discs on all cryogenic lines
- Automatic notifications - FedEx fire dept., Memphis fire dept.
- Safety Testing
 - Factory acceptance test of dispenser – 1.25x working pressure
 - Line pressure test
- Safety Code Compliance & Permitting
 - Memphis-Shelby County Airport Authority
 - Memphis Fire Service Bureau
- First responder training

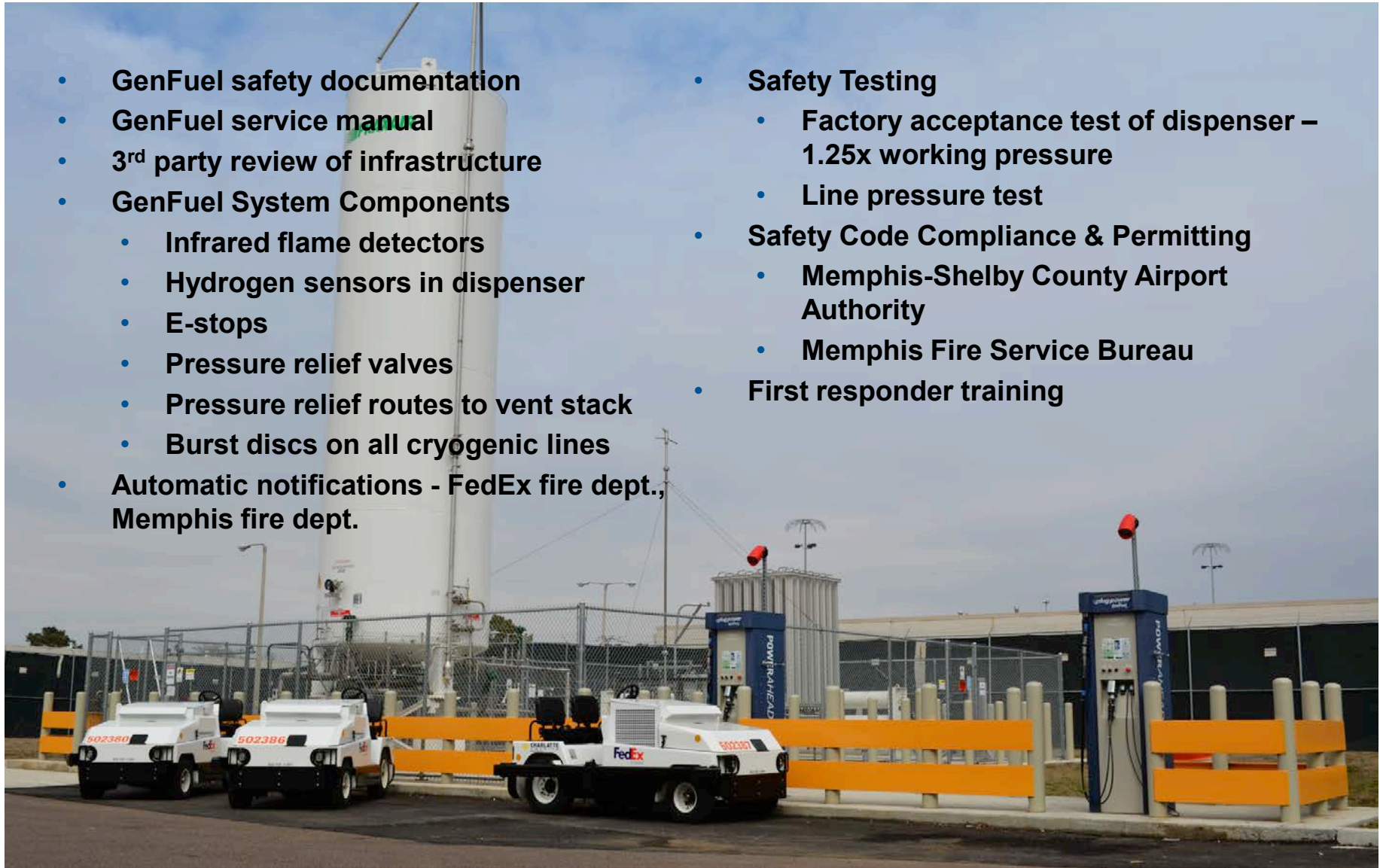

All-inclusive Offering

Approach is make the solution transparent to the customer operations:

- **Tractor operation is equal or better than a battery**
- **Customer does not need to handle hydrogen supply logistics**
- **Operator experience is the same**
- **Asset uptime is guaranteed**
- **Refueling is as easy as fueling with diesel**

GENDRIVE

A model of efficiency and progress, your GenDrive-powered fleets never stop. Just like your business.

Seamless solution for economically viable hydrogen fuel cell power

GENKEY

GENFUEL

With more than 90% of global hydrogen refuelings going into a Plug Power product – we know hydrogen.

Comprehensive care guarantees uptime and allows you to do what you do best – run your business.

GENCARE

ACCOMPLISHMENTS

Systems Modeling

- Stack Sizing
- Battery Sizing
- Balance of Plant design

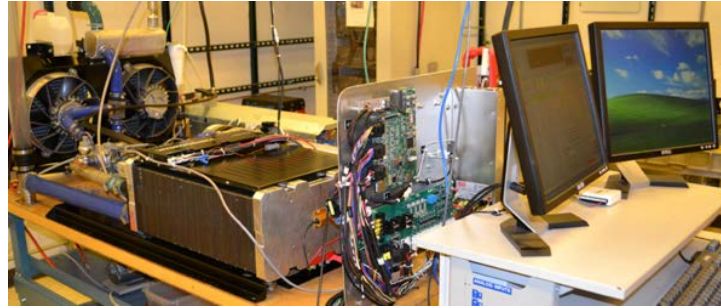

Bench Testing

Testing Achievements

- Automated testing
- Graphic interface
- Liquid-cooled load banks
- Safety sensors/E-stops
- Computer-controlled load profile management

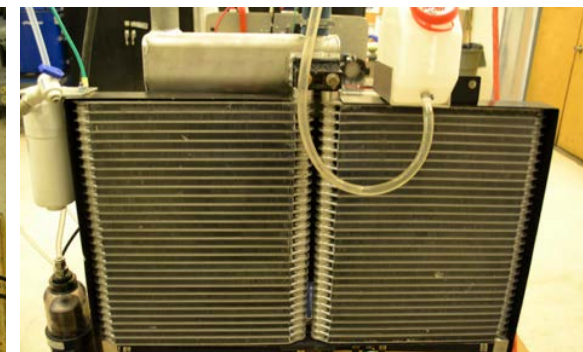
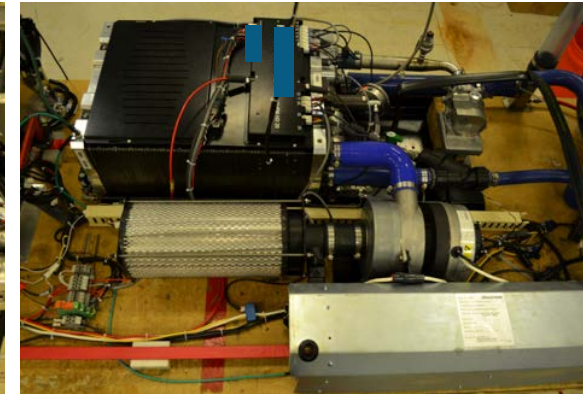
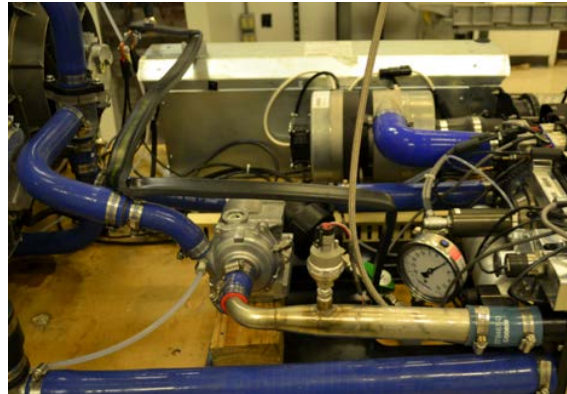

Alpha Prototype

- **Advanced packaging design**
- **Easy top serviceability of all major components**
- **150 liter (3.6 kg) H₂ tank**
- **Driver-side fueling**
- **Extended Li-Ion battery capacity**
- **Vibration dampening frame**
- **Weatherproofing**

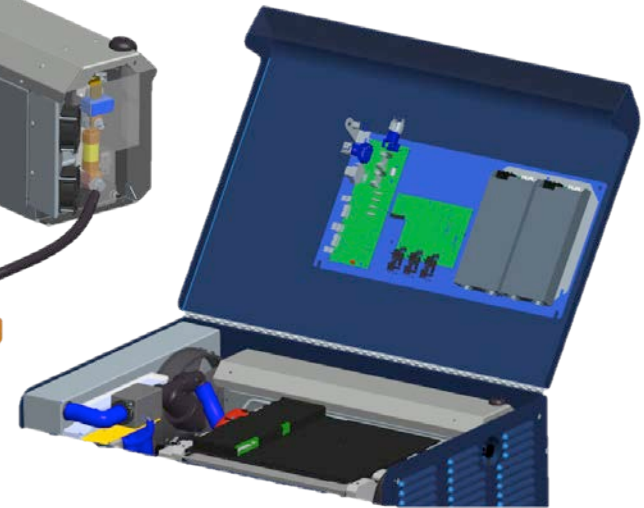
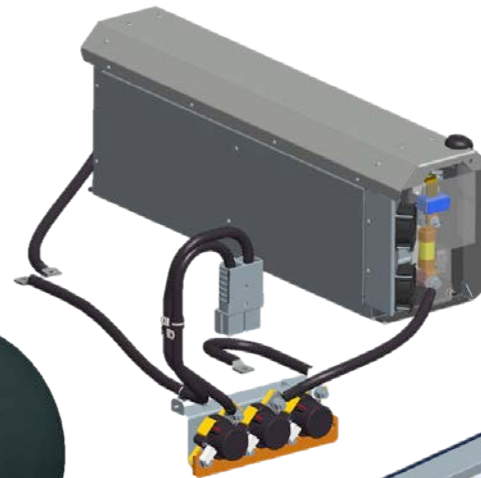
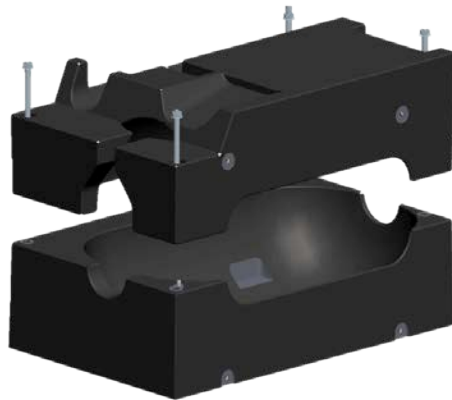

Alpha Prototype

- **Charlatte CT5E tug, FedEx Express dollies, and 40,000 lbs. of weight**
- **Endurance testing**
- **Software/diagnostics testing**



Airport application is 24/7 outdoors
Tractors are exposed to the elements

Testing at Extremes

Environmental Chamber Testing

- Designed, tested, stack and battery freeze protection down to -20 deg F
- Tested heat rejection up to 108 deg F at nominal stack temp

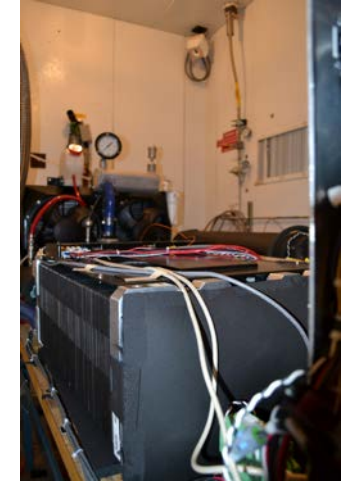

Wind Driven Rain Testing

- Rain at 30 mph at 6 different angles



Statement of Work / Progress

Will update with Gantt chart

Budget
Period 1

- **Task 1: Definition of Requirements** Complete
- **Task 2: Alpha Prototype** Complete
- **Task 3: BTT Beta Builds** Complete
- **Task 4: BTT Testing and Certification** Complete

Budget
Period 2

- **Task 5: Site Preparation** Complete
- **Task 6: Commissioning** Complete
- **Task 7A: 1st Year of Demonstration** Complete
- **Task 8: Assessment after Year 1** April 2016

Budget
Period 3

- **Task 7B: 2nd Year of Demonstration** Apr'16-Apr'17
- **Task 9: Assessment after Year 2** Apr'17

Data Collected During Year 1



Performance during Year 1 fell short of demonstration targets

- Power: Capable of 5,000 lbs. drawbar capacity
- Availability: > 80%
- Run time: > 1 shift
- Reliability (MTBF – Mean Time Between Failures): > 100 hours
- Speed rating: 10 mph
- Outdoor operation: no non-recoverable issues
- Hydrogen Fills: 350 bar

System	Time (GMT)	Stack Hours	Stack Starts	System Hours	System Starts	Power	Total H2	Tank Fills
GD76B01	42415.92	75.9	3514	1053.7	227	746.9	107552	105
GD76B02	42344.8	71.2	1757	1869	304	643.6	80844	139
GD76B03	42435.67	87.4	5598	2103.6	277	746	72957	167
GD76B04	42390.74	141	2879	1811.9	284	594.1	127266	120
GD76B05	42410.28	151	3646	2278.6	346	1659.7	215498	153
GD76B06	42445.08	154.1	3861	2382.9	363	1666.9	129363	154
GD76B07	42443.69	54.5	1660	1298.5	226	497.9	66622	111
GD76B08	42397.73	83.1	2624	1508.5	229	760	74420	126
GD76B09	42214.83	4.5	89	186.9	29	49	10998	22
GD76B10	42445.11	100	3009	1604.8	393	1035.6	81782	177
GD76B11	42390.7	93.5	2306	1326.1	348	1005.8	96403	159
GD76B12	42241.44	34.2	1133	759.2	141	374.8	53706	67
GD76B13	42445	78.7	2624	1554.9	273	754.1	66692	92
GD76B14	42445	81.4	2560	1429.3	287	762.3	78037	144
GD76B15	42424.83	71.1	3908	1521.6	239	651.4	74328	95

Fleet	Stack Hours	Stack Starts	System Hours	System Starts	Power	Total H2	Tank Fills
Units	hrs	#	hrs	#	kW-hr	kg	#
Parameter	1281.6	41168	22689.5	3966	11948.1	1336	1831

Experience Real World Conditions

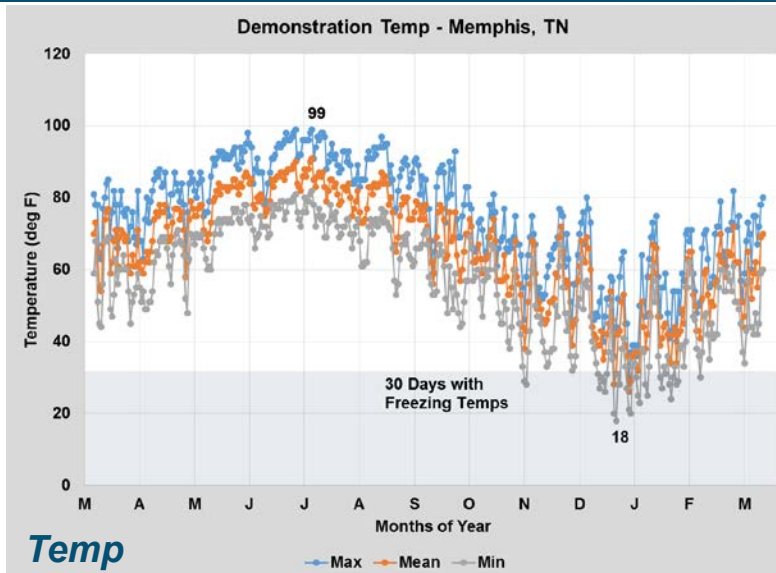

Temp

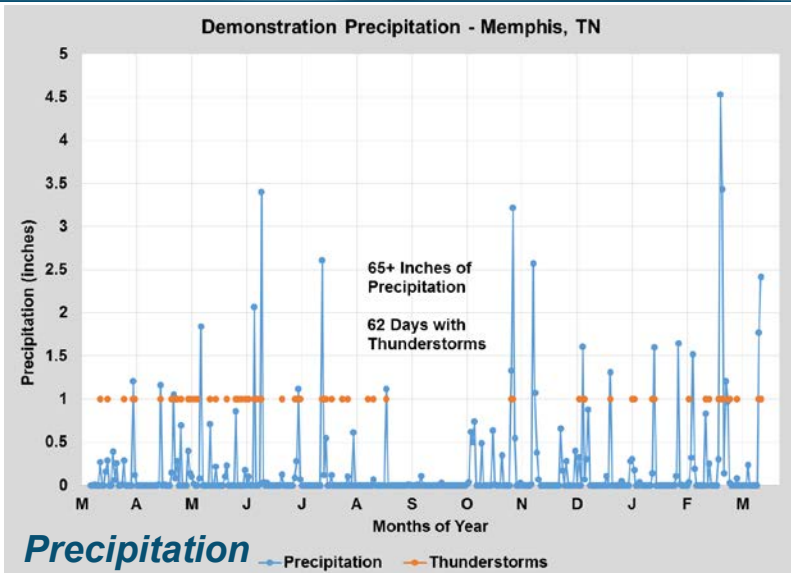

Precipitation

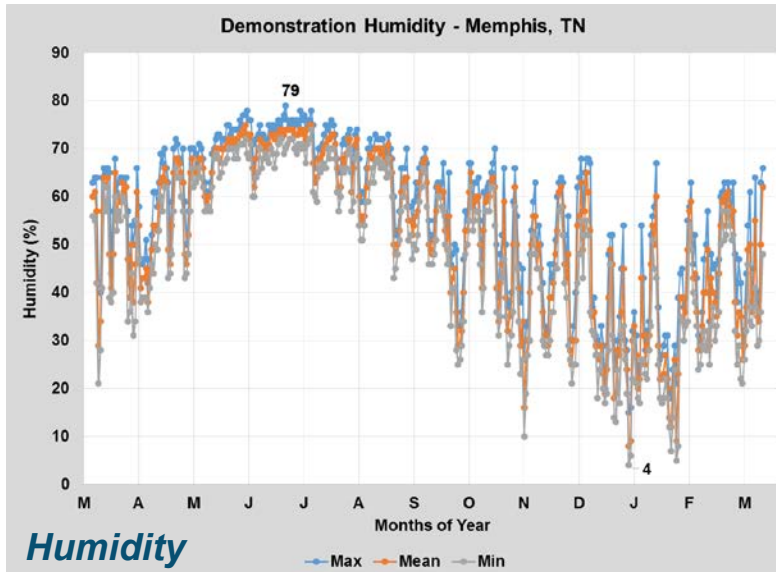

Humidity



Shock and vibe

Tractor handles application load

Operating outdoor 24/7 is not a problem

Weatherproofing strategy works well

Air filtration protects the system from airport hydrocarbon emissions

Tractor can operate worst route for full shift without needing to refuel

Handful of components that had a drastic effect on reliability

- **Problem components have been identified**
- **Alternates have been identified and tested**
- **Plan for retrofitting is in place**
- **Executing plan toward Tractor version 2.0**

FUTURE WORK

Tractor Version 2.0

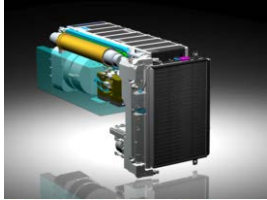

UPGRADE

- Replacement of problematic components
 - Same architecture
 - For scaling to 20 kW, some components were different than GenDrive productions for forklift trucks
 - Did not see the same performance; replacements tested for ~ 1 year



- FedEx Express more involved in service
 - FedEx technicians performing PMs
 - Working together on day-to-day fixes
 - Diagnostics

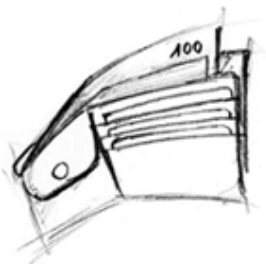

- Evaluation
 - Better integration in FedEx Express resource tracking system
 - Total Cost of Ownership economic validation

One year of demonstration with Tractor Version 2.0

SUMMARY

Objectives

FC development

- Cost-competitive
- More energy-efficient
- Reduce consumption of diesel
- Lower carbon emissions
- Decreased energy expenditures
- Validate value proposition

Major Contributions by Partners

- PP: FC system integrator
- Charlotte: Testing with CT5E tug
- PP: Liquid Hydrogen Installation
- FedEx Express: End User Evaluation

Fuel Cell Development

- Alpha prototype fully tested
- Beta prototype fully test
- Demo units received in 2014

H2 Infrastructure

- Site planning through Q3 2014
- Installation in Q4 2013
- Hydrogen site permitted in March 2015

Demonstration

- Started April 2015
- Event at FedEx Memphis in April 2015





Corporate Headquarters

968 Albany Shaker Road, Latham, NY 12110

West Coast

15913 E. Euclid Avenue, Spokane, WA 99216

plugpower.com