

Laser 3D Printing of Highly Compacted Protonic Ceramic Electrolyzer Stack

PI: Jianhua “Joshua” Tong

Co-PIs: Kyle S. Brinkman, Fei Peng, and Hai Xiao

Clemson University

May 30, 2020

Project ID: ta025

Overview

Timeline

- **Project Start Date: 10/01/18***
 - **Project End Date: April/30/21**
 - **Budget Period 1: 10/01-04/30/20**
 - **Percent Complete (BP1): ~99%**
- * Project actual start date is 11/06/18

Budget

- **Total Project Budget: \$2M**
- **Total Recipient Share: \$400K**
- **Total Federal Share: \$1.6M**
- **Total DOE Funds Spent*: \$784,132.55**
- **Total Recipient Funds Spent*: \$241,433**

* As of April/30/20

Barriers

– Capital Cost

Capital cost of water electrolysis system is prohibitive to widespread adoption

– System Efficiency and Electricity Cost

Low cost cell stacks addressing efficiency are needed

– Manufacturing

Electrolysis units are produced in low volume. Fabrication technology is high capital intensive.

Partners

- **Clemson is the sole award recipient**
- **Industrial board is being established**
- **Clemson is interested in partnering with lab and industrial collaborators**

Relevance

Objectives: This project will design, understand, develop, and demonstrate a laser 3D printing (L3DP) technology for cost-effective, rapid, and flexible manufacturing high-performance intermediate-temperature (IT, 350-650°C) protonic ceramic electrolyzer stacks (PCESs) for H₂ production at various scales to meet DOE's H₂ production objectives.

Project Targets: **1)** A PCES composed of >5 single cells with total area >100cm² will be manufactured by the L3DP technology. **2)** The current density >1A/cm² at 1.3 V and degradation rate <1% per 1000h at 600°C will be achieved. **3)** The H₂ cost based on the initial TEA should decrease >50% compared to the state-of-the-art electrolyzers and show the trend to be close to \$2/kg. **4)** The TRL will be boosted to >4 and the potential industrial partner will be found and scale-up plan should be made.

Budget Period 1 Target: **1)** PCES single cells with area >5cm², current density >500mA/cm² at 1.3V and stable operation with degradation rate <1% for >200h at 600°C by L3DP. **2)** The rough order of magnitude calculation will show the potential for the L3DP technology to be cost incentive comparing to conventional technologies.

Approach

1. PCES Materials Development
2. PCES Component Thin Films by L3DP
3. PCES Single Cells by L3DP
4. Five-Cell PCES by L3DP
5. Initial TEA and Market Transformation Plan

PCES, protonic ceramic electrolyzer stack

L3DP, laser 3D printing

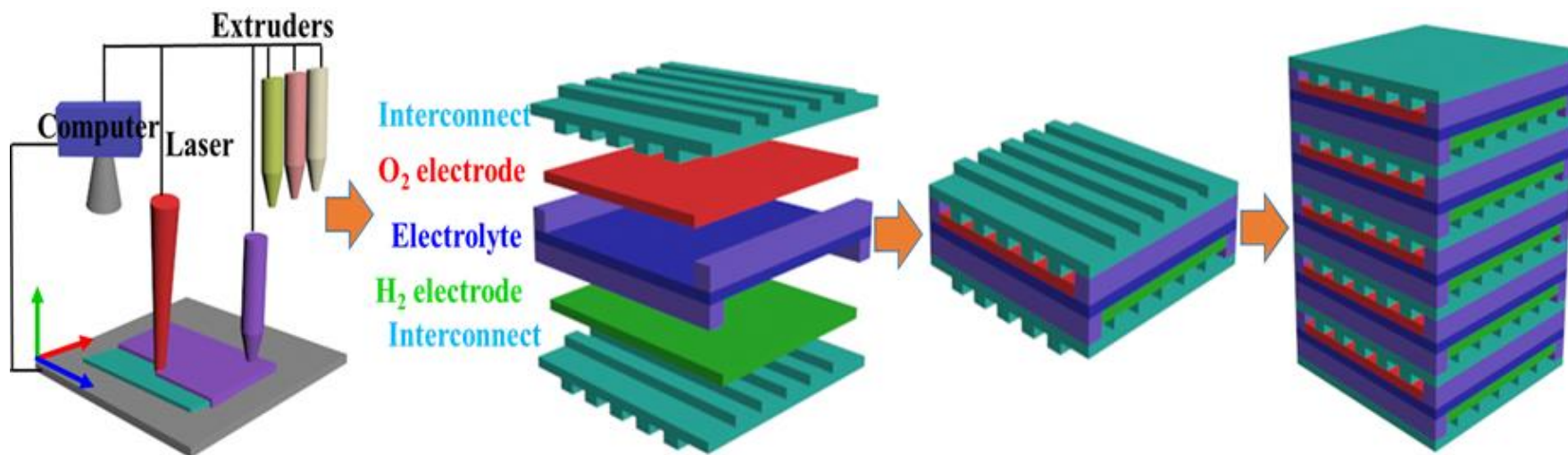

Approach-BP1

1. Develop intermediate temperature protonic ceramic electrolyzer materials and demonstrate good water electrolysis and fuel cell performance.

Address barriers: F capital cost and G system efficiency by improving electrolyzer power density and durability at lower temperatures (e.g., 600°C).

2. Laser 3D print high-quality component films and protonic ceramic electrolyzer single cells.

Address barriers: F, capital cost, G. System efficiency, K manufacturing by rapidly, digitally, and cost-effectively fabricating protonic ceramic electrolyzer with high volumetric power density.

Manufacturing of cost-effective electrolyzers for H₂ production through H₂ electrolysis at various scales.

Approach-Milestone

Budget Period 1: Protonic Ceramic Electrolyzer Single Cells by Laser 3D Printing

| Task # | Milestones | Task Completion Date | |
|--------|---|----------------------|------------|
| | | Planned | % Complete |
| 1.1 | Discovery of new PCES materials (Discover compatible electrolyte, O ₂ /H ₂ electrodes, and interconnect with low ASRs) | 01/31/2020 | 100% |
| 1.2 | High materials performance in PCES single cells from selected materials fabricated by solid state reactive sintering | 01/31/2020 | 90% |
| 2.1 | 3D printing of component large-area, crack-free green films | 01/31/2020 | 100% |
| 2.2 | Rapid laser reactive sintering (RLRS) of component large-area crack-free thin films | 01/31/2020 | 100% |
| 3.1 | Effective binding of PCES component films | 04/30/2020 | 100% |
| 3.2 | Effective infiltration in the L3DP electrode nanoparticles showing OER and HER | 04/30/2020 | 100% |
| 3.3 | Demonstrate high-performance PCES single cell fabrication by L3DP | 04/30/2020 | 100% |
| 3.4 | The rough order of magnitude calculation to show the L3DP has potential to offer lower cost than conventional technologies | 04/30/2020 | 100% |
| GNG | Demonstrate PCES single cells with area >5cm ² , current density >500mA/cm ² at 1.3V and stable operation with a degradation rate <1% for >200h at 600°C by L3DP. | 04/30/2020 | 100% |

Accomplishments and Progress

Task-1 PCES Materials Development

- The new protonic ceramic electrolyte of BCZYSm showed a proton conductivity close to 10^{-2} Ω/cm at 600°C . The ASR for this electrolyte with a thickness around $10\mu\text{m}$ reached to $0.1 \Omega\cdot\text{cm}^2$ at 600°C .
- The BCFZY0.1 thin-film oxygen electrode prepared through a new intermediate precursor showed an ASR of $0.053 \Omega\cdot\text{cm}^2$ at 600°C .
- The commonly used interconnect of LSCr was synthesized, and the total electrical conductivity of $16.2 \text{ S}/\text{cm}^{-1}$ was obtained.
- The total polarization for the hydrogen electrode of BCZYYb + NiO and the oxygen electrode BCZY63+ BCFZY0.1 showed an ASR of $0.2 \Omega\cdot\text{cm}^2$ at 600°C .
- A single cell based on BCZYSm prepared by SSRS method showed a current density of $1050\text{mA}/\text{cm}^2$ at 600°C and 1.3V when operating in the electrolysis mode. The stable current density of $640\text{mA}/\text{cm}^2$ was obtained for more than 110hrs BCZYSm based single cells.

Accomplishments and Progress

Task-2 PCES Component Thin Films by L3DP

- The recipe for achieving printable pastes of protonic ceramic-based materials was developed, which allowed us to 3D print crack-free PCES component green films with areas $>100\text{cm}^2$ and thickness 30-1000 μm .
- The fully densified electrolyte films with individual area $>10\text{cm}^2$ and thickness 9-100 μm were prepared by the RLRS method either in the half cell or single-cell configurations. A summary of $\sim 120\text{cm}^2$ crack-free half cells were obtained. The ASR of the electrolyte reached to $\sim 0.08\Omega\cdot\text{cm}^2$.
- The porous hydrogen electrodes with an individual active area of $>10\text{cm}^2$ (summary area $>120\text{cm}^2$) were obtained RLRS, which showed ASR $\sim 0.0744\Omega\cdot\text{cm}^2$ at 600 $^\circ\text{C}$.
- The porous oxygen electrode scaffold with an individual area $\sim 6\text{cm}^2$ was prepared by RLRS in the single-cell configuration, which showed ASRs $\sim 0.1\Omega\cdot\text{cm}^2$ at 600 $^\circ\text{C}$.
- The fully densified phase-pure LSCr interconnect film with thickness $\sim 10\mu\text{m}$ and active area $\sim 7\text{cm}^2$ were prepared by RLRS, which showed an ASR $\sim 0.001\Omega\cdot\text{cm}^2$ at 600 $^\circ\text{C}$

Accomplishments and Progress

Task-3 PCES Single Cells by L3DP

- The single cells (0.2cm^2) with half cells fabricated by L3DP showed current density $\sim 1.36\text{A}/\text{cm}^2$ at 600°C at 1.3V . During the operation of 163h , the current density increased from $1.161\text{A}/\text{cm}^2$ to $1.794\text{A}/\text{cm}^2$.
- The single cells fabricated by one-step RLRS showed an electrolysis current density of $\sim 1.75\text{A}/\text{cm}^2$ for ~ 200 hrs without any degradation.
- A combined single cell ($\sim 6.6\text{cm}^2$) was tested by integrating seven small cells manufactured by one-step RLRS. A stable current density of $\sim 350\text{mA}/\text{cm}^2$ at 600°C and 1.3V was achieved during 200 hrs.
- The rough-order-of-magnitude manufacturing cost estimation showed that L3DP technology has a potential to offer lower price for manufacturing solid oxide electrolyzer stack than the conventional technologies. Comparing with conventional electrolyte-electrode assembly method, the L3DP can allow the materials to decrease 31.3% , the process decrease 31.2% , and the energy and power decreases 62.2% .

MS1-Discovery of New PCES Materials

BCZYSm Electrolyte

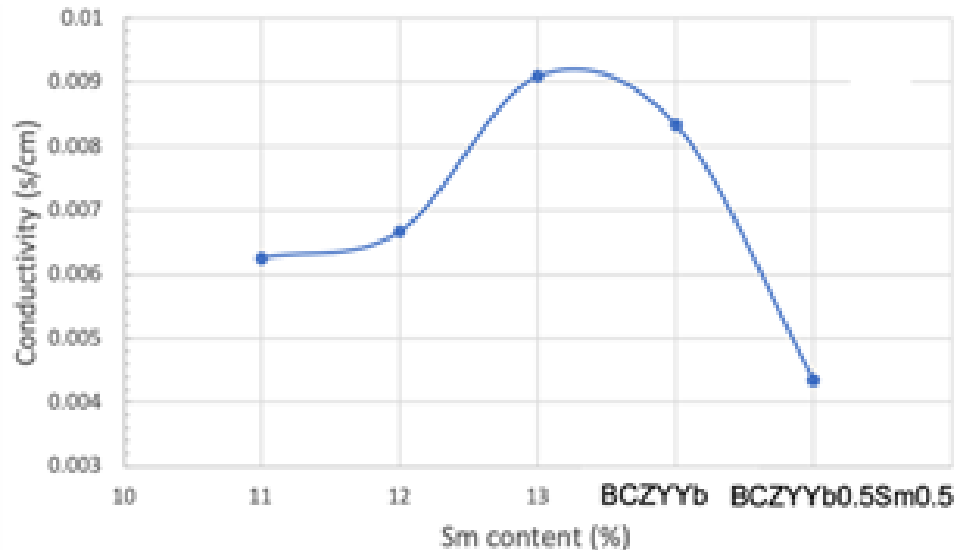

Total conductivity VS temperature in wet 5% H₂

The new electrolyte material of BCZYSm was discovered with a total proton conductivity near to $2 \times 10^{-2} \Omega^{-1} \cdot \text{cm}^{-1}$.

High-performance electrodes

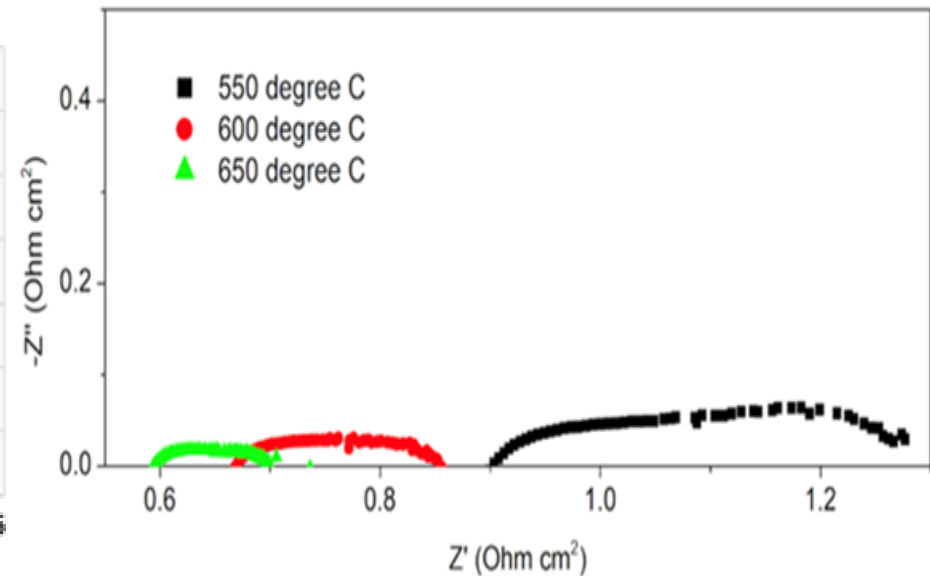

ASRs of total electrode polarization based on the EIS measurement of single cells.

The total ASR of O₂ and H₂ electrodes is ~0.2 Ω·cm² at 600°C, which reached to milestone of 0.1 Ω·cm² for each.

MS2- Materials Performance in PCES Single Cells

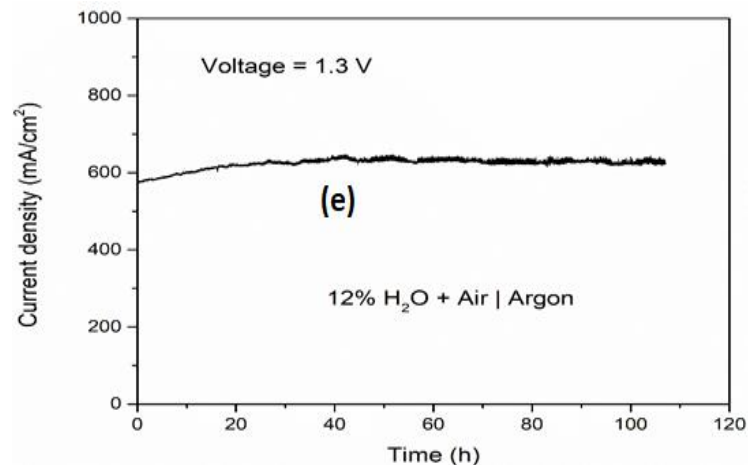
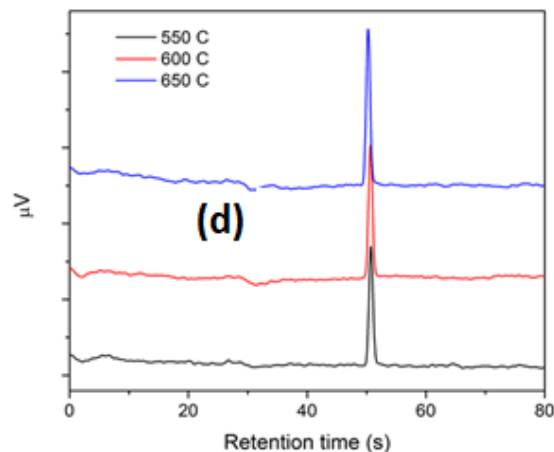
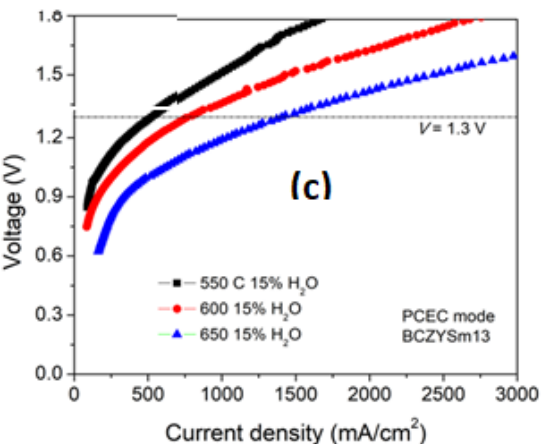
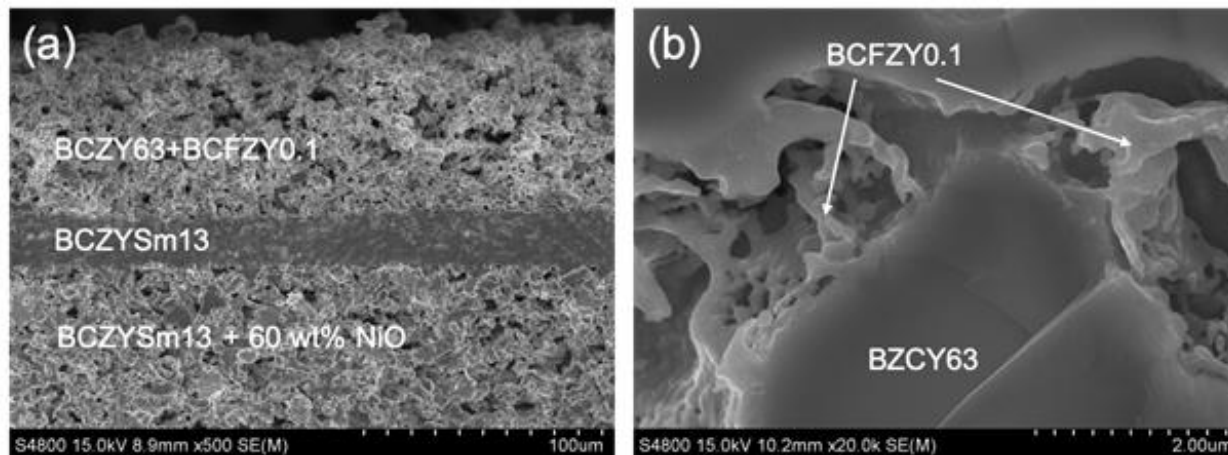

Microstructure and electrolysis performance of BCZYSm based single cells fabricated by SSRS

The new single cell based on BCZYSm obtained by solid state reactive sintering showed a current density as high as $1050 \text{ mA}/\text{cm}^2$ at 1.3 V and 600°C . The long-term test over 110 hrs showed no degradation for electrolysis with a current density $\sim 640 \text{ mA}/\text{cm}^2$.

MS3-3D Printing of Component Green Films

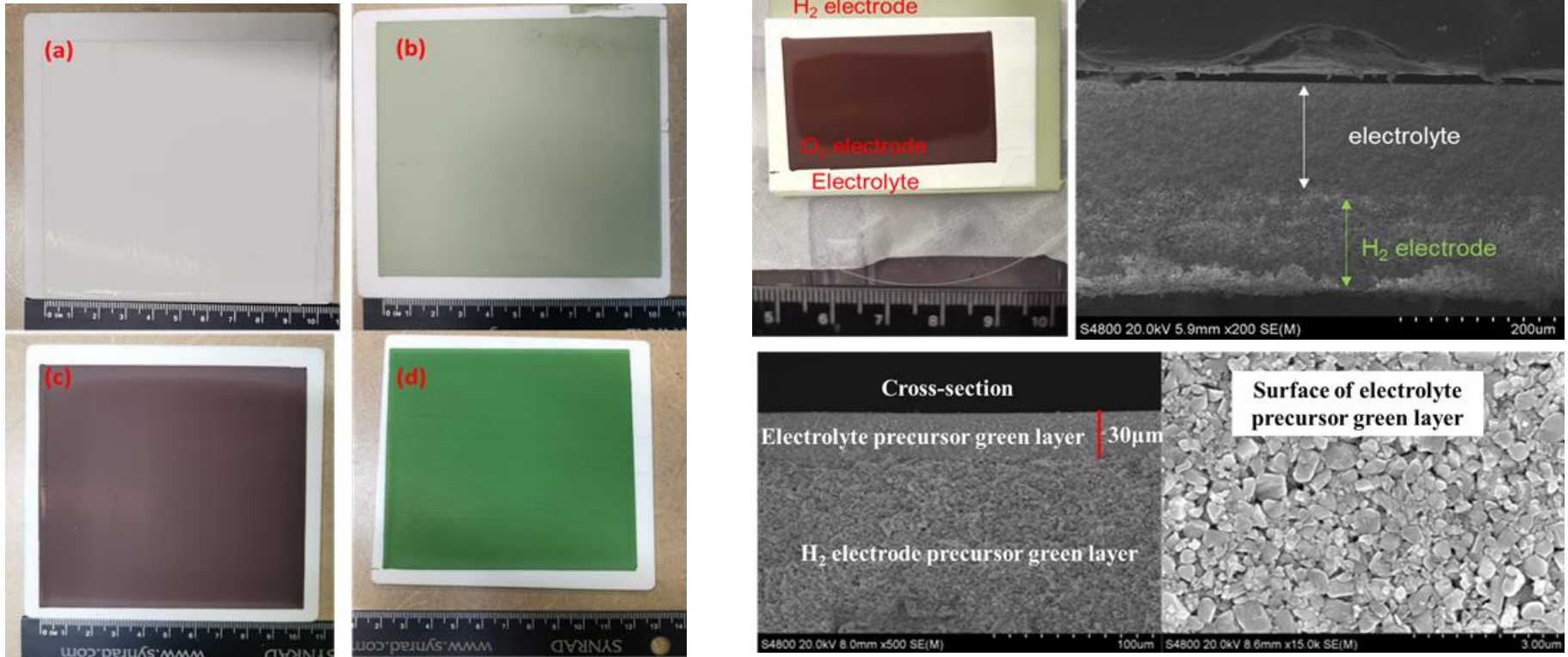

Photos and SEM images of 3D printed green films by microextruder or spray coating based 3D printing

The pastes for model component materials have been prepared for printing defect-free homogenous layers with effective area $>100\text{cm}^2$. The bonding is good and the thickness can be controlled to be 30-1000µm.

MS4-RLRS of Component Thin Films

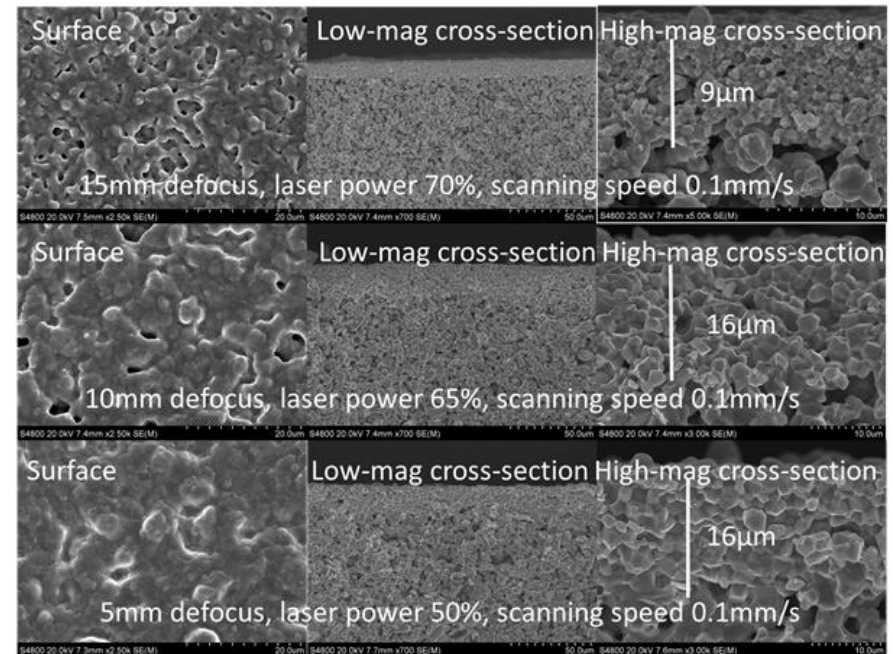
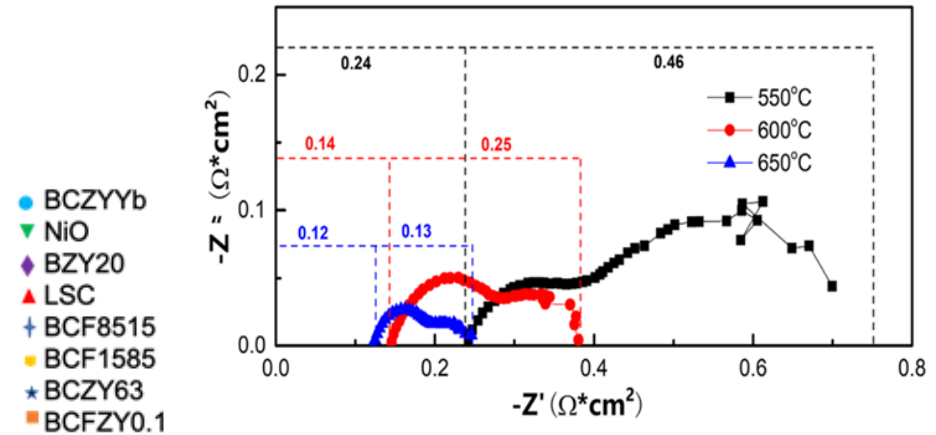
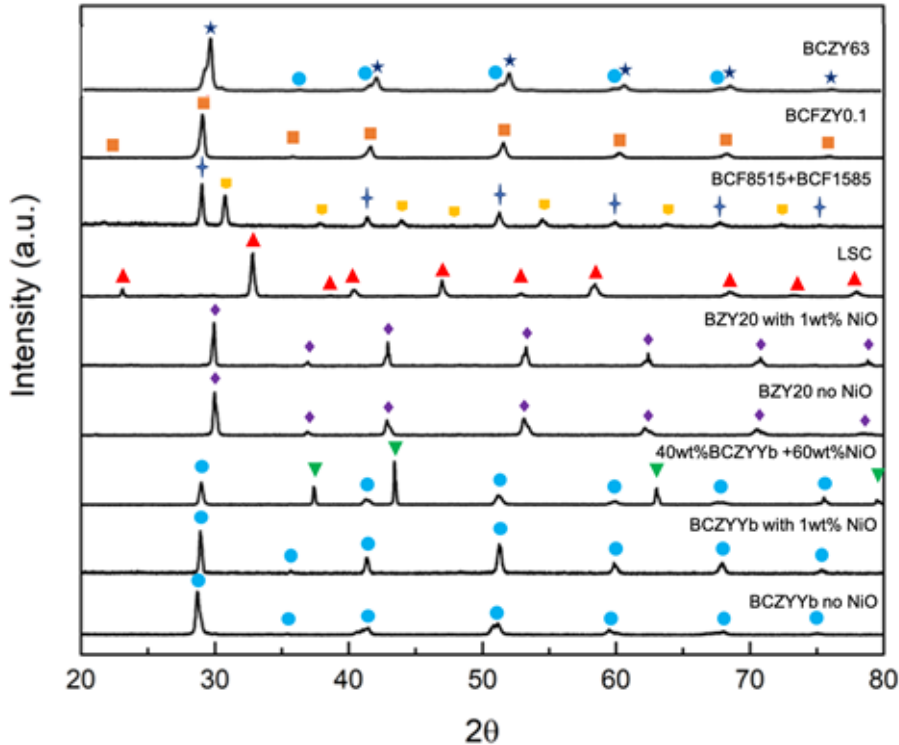

RLRS can achieve desired crystal structure, microstructure and electrochemical properties for the protonic ceramic thin films with area $>10\text{cm}^2$.

MS5-Bonding of Component Thin Films

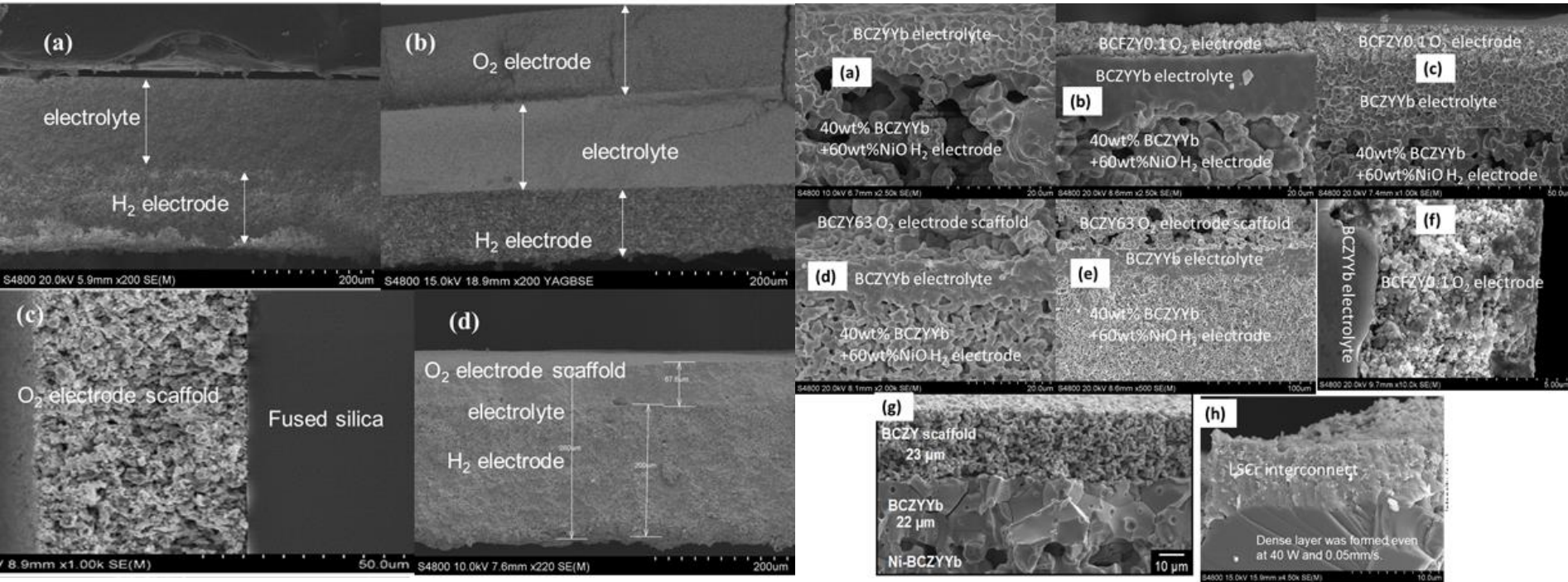

SEM images of 3D printed thin films, half cells, and single cells by microextrusion or spray coating.

SEM images of 3D printed thin films, half cells, and single cells after rapid laser reactive sintering.

Efficient bonding without apparent interfacial and component performance deterioration was achieved for both green layers and sintered layers.

MS6-Infiltration Electrode Nanoparticles

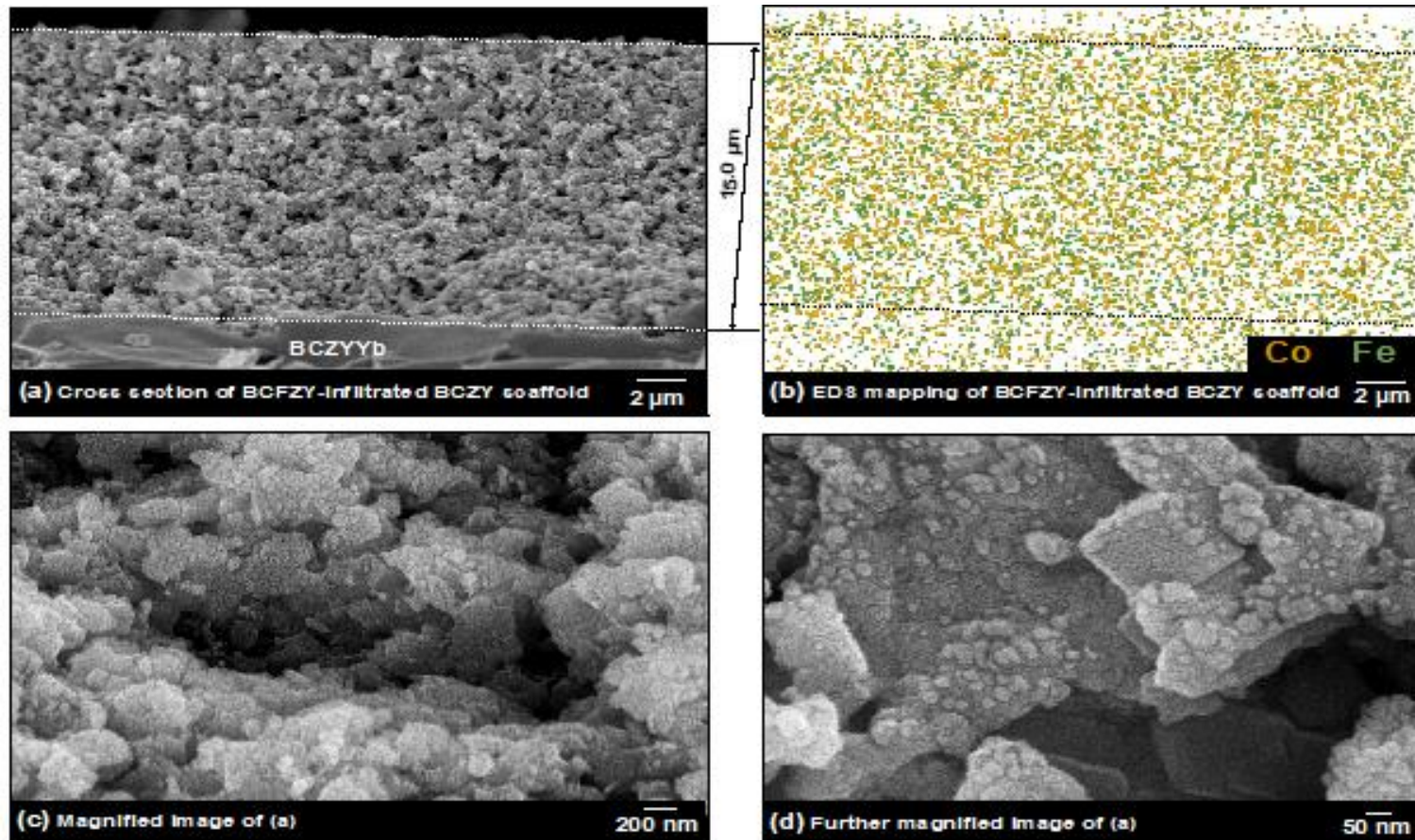

SEM images and EDS map of BCFZY0.1 infiltrated BCZY63 O₂ electrode scaffold

The effective infiltration in the O₂ electrodes obtained RLRS has been achieved.

MS7-Single Cells by RLRS

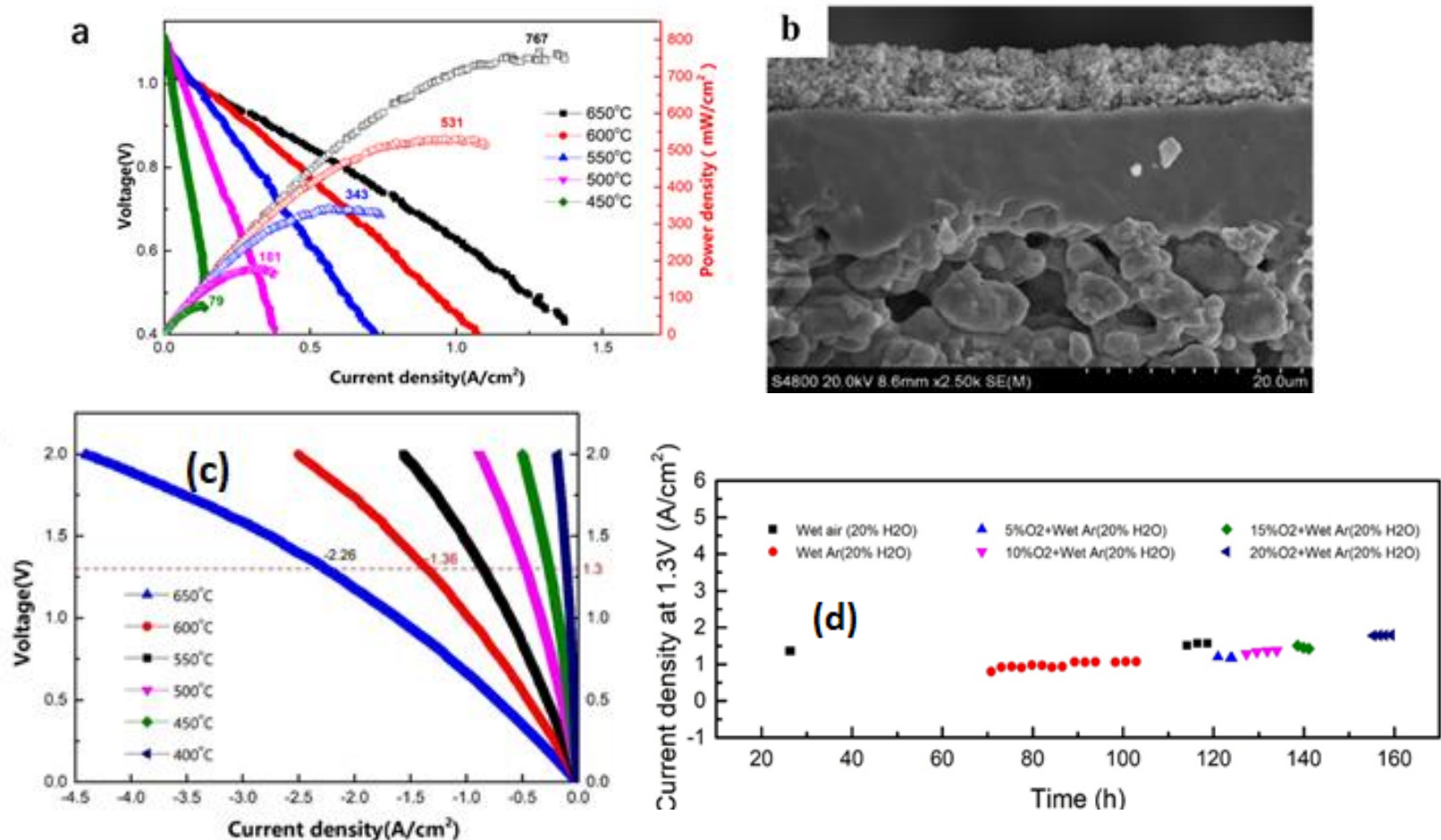

The single cells with half cells prepared by RLRS showed peak power density of 531mW/cm² and current density of 1.36A/cm² for fuel cell and electrolysis cell operation, respectively. Stable operation with current density ~1.7A/cm² was obtained for ~166hrs.

MS7-Single Cells by RLRS

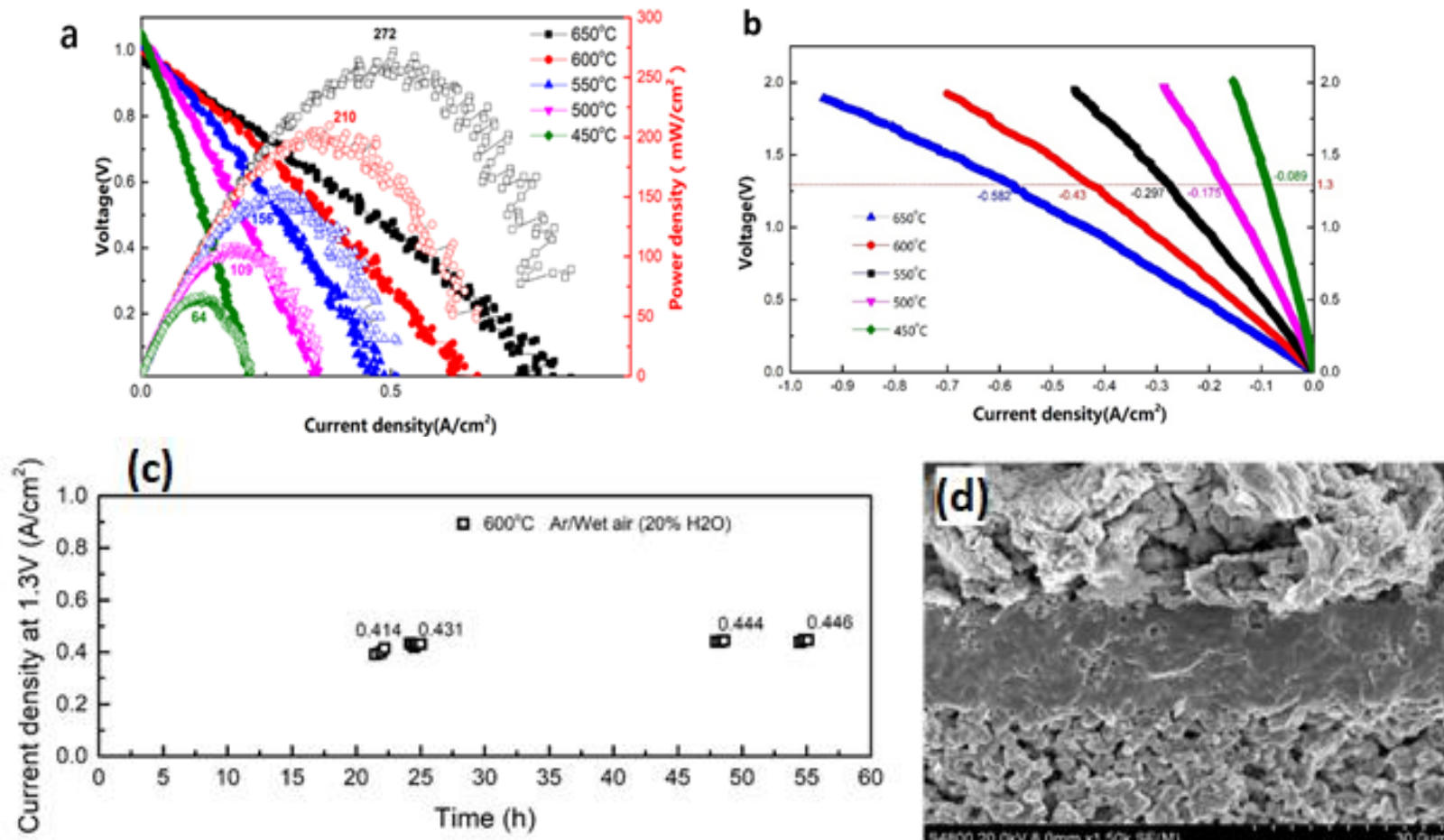

The single cells prepared by one-step RLRS showed peak power density of 220 mW/cm² and current density of 0.43A/cm² for fuel cell and electrolysis cell operation, respectively. Stable operation with current density ~0.446A/cm² was obtained for more than 55hrs.

MS7-Single Cells by RLRS

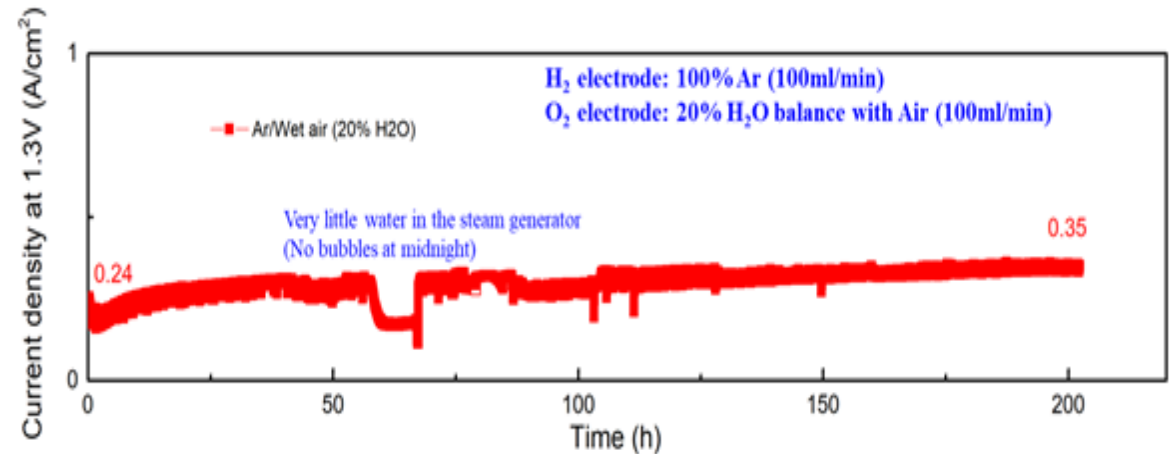

Long-term stability test of a large-area (~6.6cm²) combined single cells prepared by a one-step L3DP method followed by infiltration

The photo of the combined single-cell prepared by one-step L3DP method. The total area is around 6.6cm²

The combined cells with a total area of 6.6cm² were prepared from single cells manufactured from one-step RLRS. The stable operation with current density ~0.35A/cm² was obtained for more than 200hrs.

MS8-Manufacturing Cost Estimation

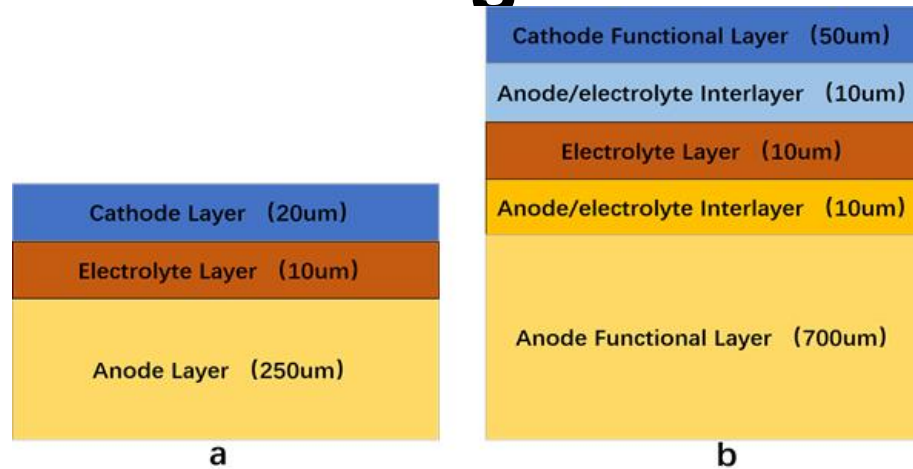

Schematic of a single cell: (a) L3DP method and (b) Traditional EEA cell

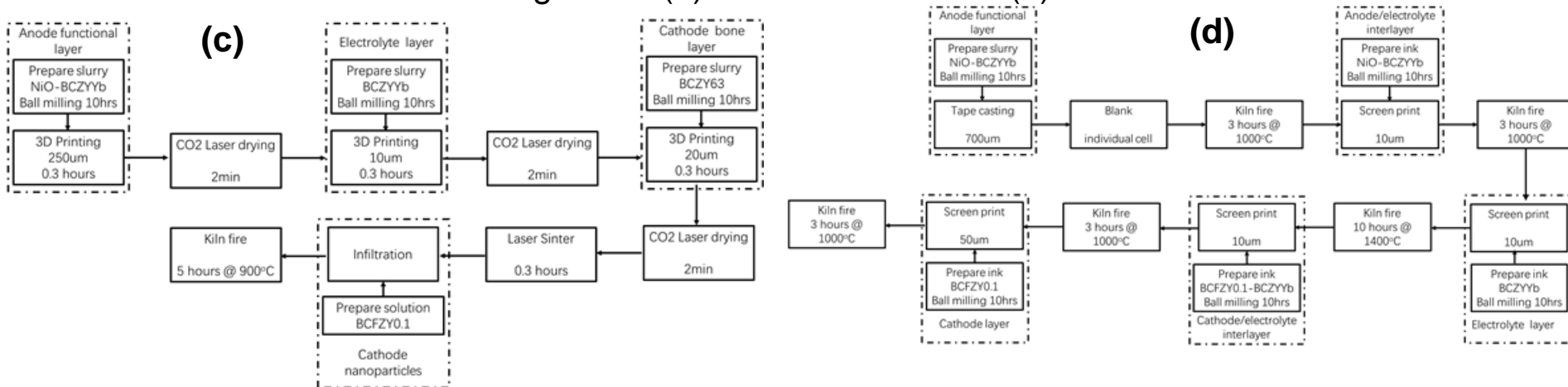

PCEC fabrication process flow. (c) L3DP Process; (d) EEA process

Comparing with conventional electrolyte-electrode assembly method, the L3DP can allow the materials to decrease 31.3%, the process decrease 31.2%, and the energy and power decreases 62.2%.

Accomplishments and Progress: Responses to Previous Year Reviewers' Comments

- The previous year reviewers' comments were not provided since only poster presentation for short term progress was presented on previous AMR meeting.
- Therefore, on responses to previous year reviewers' comments are reported here.

Collaboration & Coordination

- Clemson University is the sole recipient of this award. The collaboration & coordination mostly occur among the principal investigators.

PI. Jianhua “Joshua” Tong, Material Science and Engineering, Clemson University Management and lead T3 PCES single cells by L3DP and T4 Five-cell PCES by L3DP and participate T1, T2, and T5.

Co-PI: Kyle S. Brinkman, Material Science and Engineering, Clemson University Lead T-1 PCES materials development and participate T2 and T4

Co-PI: Fei Peng, Material Science and Engineering, Clemson University Lead PCES Component Thin Films by L3DP and participate T3 and T4.

Co-PI: Hai Xiao, Electrical and Computer Engineering, Clemson University Update and maintain L3DP equipment and Lead T-5 TEA and Market Transformation Plan and participate T3 and T4.

- Industrial advisory board is being established.
- Clemson is interested in partnering with lab and industrial_{2,1} collaborators.

Remaining Challenges and Barriers

As laser 3D printing of protonic ceramic electrolyzer stack, the overall challenge is to:

- 1) Achieve large-area component films without any cracks by rapid laser consolidation technique
- 2) Apply new layers on the previously sintered layers.
- 3) Control the crystal structure, microstructure, and composition simultaneously during rapid laser reactive sintering.

Proposed Future Work

By April 30, 2021

Due to Covid-19 pandemic, the long-term test of 1000 hrs for single cells (milestone 2 in BP 1) has not been finished yet. We demonstrated more than 100 hrs stability. When the university comes back to normal operation, this long-term test can be done quickly.

T-4: Five-cell PCES by L3DP

| | | | | | |
|-----|--------------------------------|----|----|---|--|
| 4.1 | Laser machining microchannels | MS | 9 | The interconnects with desired microchannels should be obtained. | No increase in mass transport resistance and no effect on current collecting. X/T at CU. |
| 4.2 | Manufacturing of PCES by L3DP | MS | 10 | The program to control L3DP to manufacture designed PCES should be achieved. | The program allows for L3DP of crack-free PCES on demand. X/T/P at CU. |
| 4.3 | Performance and stability test | MS | 11 | High performance PCES manufactured by the proposed L3DP will be demonstrated. | >5 cells, >100cm ² , >1A/cm ² at 1.3V, <1% degradation per 1000h. T/P/X/B at CU. |

T-5: Initial TEA and market transformation plan

| | | | | | |
|-----|----------------------------|----|----|--|--|
| 5.1 | Initial TEA | MS | 12 | Analyze the electrolyzer manufacturing cost for predicting H ₂ cost by H2A3. | Manufacturing cost decrease should be >50%. T/X at CU |
| 5.2 | Market transformation plan | MS | 13 | The industrial partner, who is interested to scale up this technology to speed up the technology | The reasonable scale-up plan should be made. X/T at CU |

End Project Goal: PCES with >5 cells, total area>100cm², current density >1A/cm², degradation rate <1% per 1000h for >1000h at 600C

Any proposed future work is subject to change based on funding levels

Technology Transfer Activities

- Our new laser 3D printing technology for manufacturing highly compacted multilayer ceramic energy devices such as fuel cell stacks, electrolyzer stacks, and ceramic membrane reactors has been successfully developed. The provisional patent was filed by Clemson University Research Foundation (CURF).
- The team is establishing industrial board and looking for industrial collaborators who are interested in either electrolyzer/fuel cell/hydrogen production or additive manufacturing of ceramic parts.

Summary

Progress and Accomplishment

We have made single cells with area larger than 10cm² by L3DP method and successfully tested a combined single cell with an active area >5cm². We have achieved an electrolysis current density as high as 1.36A/cm² at 600°C under 1.3V for our single cells prepared by L3DP. We have demonstrated that our L3DP-manufactured single cells could operate more than 200 hrs without any degradation. We have shown that our L3DP PCES has significant cost superiority to the traditional manufacturing based on a rough order of magnitude estimation.

Therefore, we concluded that we have entirely met our Go/No-Go Point.